

human metabolism

LECTURE NOTES

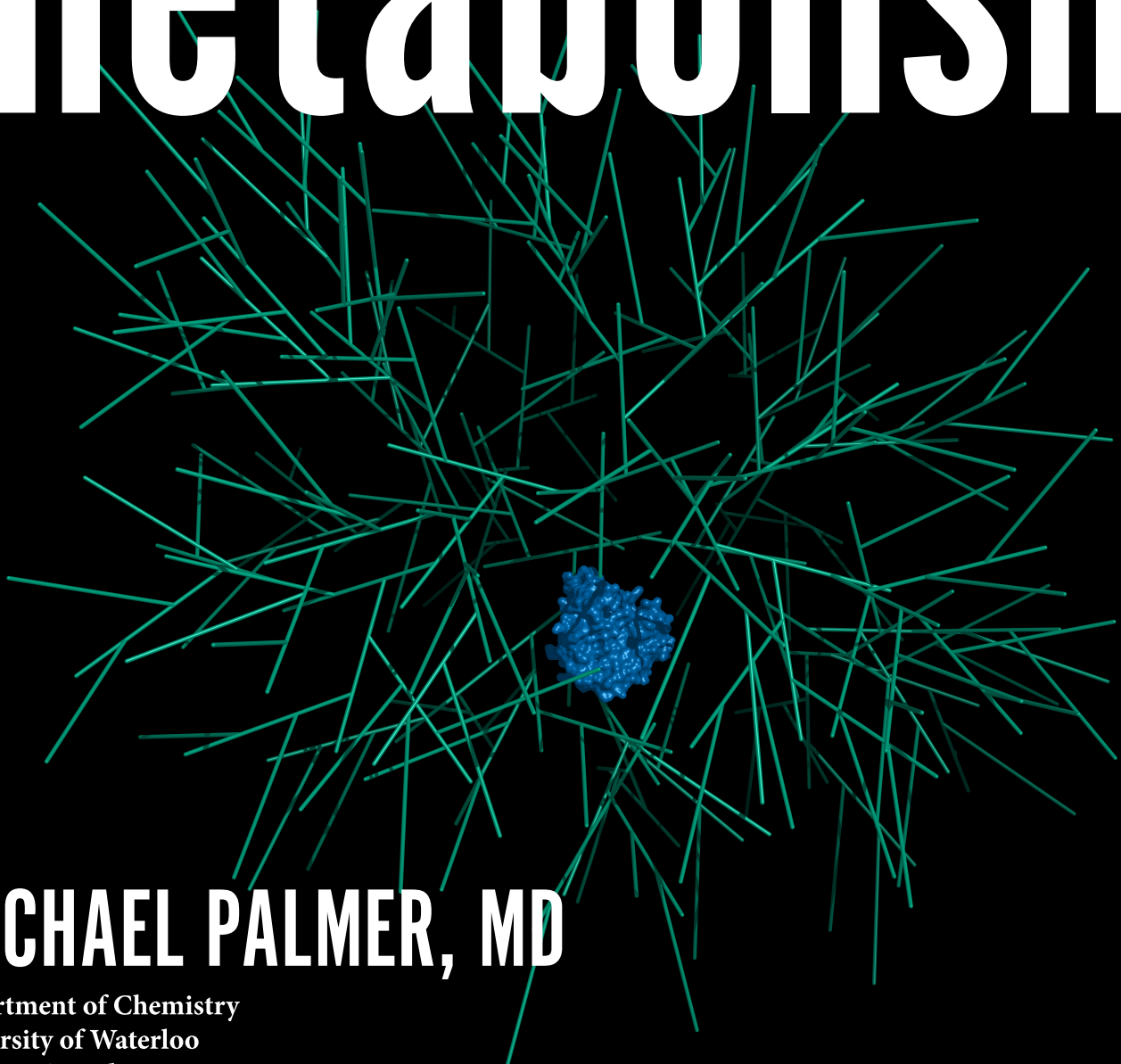

MICHAEL PALMER, MD

Department of Chemistry
University of Waterloo
Ontario, Canada

Human metabolism lecture notes

Michael Palmer, MD

Department of Chemistry
University of Waterloo
Waterloo, ON N2L 3G1
Canada

mpalmer@uwaterloo.ca

This version is from Friday 10th April, 2015. The latest electronic version of these notes and accompanying slides is available for free at

watcut.uwaterloo.ca/webnotes/Metabolism/.

No other website is authorized to publicly distribute these notes or accompanying slides.

A printed version (full color, hardcover binding) is now available at [amazon](#) and other retailers. For bulk orders at reduced rates, contact me directly.

Preface

These lecture notes, and the accompanying slides, are intended for teaching human metabolism at the undergraduate level. They aim to give a big picture view of the field that takes into account physiological and some clinical aspects. They also strive to be up to date. Some biochemistry texts present all the latest and greatest enzyme crystal structures, but seem stuck in the 1960s when it comes to updating metabolic pathways. It is likely that these notes are not completely free from this disease either, and I therefore welcome any corrections and suggestions for improvement.

The notes and the slides are meant to be used in conjunction; the notes mostly present the slides in sequence, augmenting each with explanatory text. Keeping the figures and the corresponding text closely together may not always look as polished as a conventional book layout, but it makes on-screen reading easier. This structure also encourages me to stay on topic and to advance the plot with each successive slide. Finally, it makes it easier to recapitulate or anticipate the content of a lecture; this goes for both the students and the lecturer.

Another conscious choice is to make these materials freely available. The text is entirely my own work. So is the majority of the images; all exceptions are listed in chapter 20. Regarding those images, I would like to thank all individuals and institutions who gave me permission to reuse them in these notes. In particular, I thank Katharina Glatz of Basel University for permission to use multiple histological pictures from her excellent website pathorama.ch. You are free and welcome to use these notes and slides for self-study or for classroom teaching. Some restrictions apply concerning the copying and redistribution of these materials; refer to the copyright notice in chapter 20 for details. I hope that, in return, you will bring to my attention any errors or shortcomings that you may notice.

I would also like to thank my students, who have helped to improve these notes by challenging and questioning me about the material and its presentation. In particular, Stefanie Malatesta and Julia Plakhotnik have helped substantially in this manner.

These notes were put together with a collection of excellent free software tools. Apart from the well-known tools \LaTeX , Pymol, and Gnuplot, I would like to highlight the outstanding `chemfig` \LaTeX package written by Christian Tellechea that was used to draw all of the chemical structures and reaction mechanisms.

Contents

Preface	iii
Chapter 1 Introduction	1
1.1 Motivation: Why would you study metabolism?	1
1.2 Significance of metabolism in medicine	1
1.3 Catabolic and anabolic reactions	2
1.4 Diversity of metabolism: pathways in plants and bacteria	3
1.5 Types of foodstuffs	4
1.6 The digestive system	6
1.7 Answers to practice questions	15
Chapter 2 Refresher	17
2.1 Preliminary note	17
2.2 How enzymes work: active sites and catalytic mechanisms	17
2.3 Energetics of enzyme-catalyzed reactions	20
2.4 The role of ATP in enzyme-catalyzed reactions	22
2.5 Regulation of enzyme activity	23
2.6 Answers to practice questions	29
Chapter 3 Glycolysis	31
3.1 Overview of glucose metabolism	31
3.2 Reactions in glycolysis	33
3.3 Mechanisms of enzyme catalysis in glycolysis	34
3.4 Glycolysis under aerobic and anaerobic conditions	40
3.5 Transport and utilization of glucose in the liver and in other organs	42
3.6 Answers to practice questions	44
Chapter 4 Catabolism of sugars other than glucose	47
4.1 Dietary sugars other than glucose	47
4.2 Degradation of fructose and sucrose	48
4.3 Lactose and galactose	50
4.4 Sorbitol is an intermediate of the polyol pathway	53
4.5 Answers to practice questions	54

Contents

Chapter 5	Pyruvate dehydrogenase and the citric acid cycle	57
5.1	Overview	57
5.2	Structure and function of pyruvate dehydrogenase	58
5.3	Regulation of pyruvate dehydrogenase	62
5.4	The citric acid cycle	63
5.5	Regulation of the citric acid cycle	67
5.6	Reactions that divert and replenish TCA cycle intermediates	68
5.7	Answers to practice questions	68
Chapter 6	The respiratory chain	71
6.1	Introduction	71
6.2	Overview	72
6.3	ATP synthesis can be separated from electron transport	73
6.4	Molecules in the electron transport chain	75
6.5	The energetics of electron transport	79
6.6	Interfacing different types of electron carriers	82
6.7	How is electron transport linked to proton pumping?	85
6.8	ATP synthesis	87
6.9	Auxiliary shuttles for the mitochondrial reoxidation of cytosolic NADH	92
6.10	Regulation of the respiratory chain	94
6.11	ATP yield of complete glucose oxidation	97
6.12	Answers to practice questions	99
Chapter 7	Gluconeogenesis	101
7.1	Introduction	101
7.2	Reactions in gluconeogenesis	102
7.3	Energy balance of gluconeogenesis	105
7.4	Interactions of gluconeogenesis with other pathways	106
7.5	Regulation of gluconeogenesis	108
7.6	Answers to practice questions	111
Chapter 8	Glycogen metabolism	113
8.1	Overview	113
8.2	Glycogen structure	113
8.3	Glycogen synthesis and degradation	116
8.4	Regulation of glycogen metabolism	121
8.5	Interorgan relationships in glycogen metabolism	123
8.6	Glycogen storage diseases	126
8.7	Answers to practice questions	128
Chapter 9	The hexose monophosphate shunt	131
9.1	Outline of the pathway	131
9.2	Reactions in the hexose monophosphate shunt	132
9.3	The physiological role of NADPH	136
9.4	Glucose-6-phosphate dehydrogenase deficiency	142

9.5	Answers to practice questions.	144
Chapter 10	Triacylglycerol metabolism	147
10.1	Overview.	147
10.2	Digestion and uptake of dietary triacylglycerol.	149
10.3	Utilization of fatty acids: β -oxidation	153
10.4	Ketone body metabolism	160
10.5	Fatty acid synthesis.	164
10.6	The glyoxylate cycle	170
10.7	Answers to practice questions.	171
Chapter 11	Cholesterol metabolism	173
11.1	Biological significance of cholesterol.	173
11.2	Cholesterol synthesis	174
11.3	Regulation of cholesterol synthesis	179
11.4	Cholesterol transport	182
11.5	Bile acid metabolism and transport	188
11.6	Cholesterol and atherosclerosis.	190
11.7	Cholesterol metabolism and the treatment of atherosclerosis	198
11.8	Gene defects in cholesterol transport and metabolism	202
11.9	Answers to practice questions.	204
Chapter 12	Amino acid metabolism	207
12.1	Metabolic uses of amino acids	207
12.2	Transamination of amino acids	209
12.3	Nitrogen disposal and excretion	211
12.4	Degradative pathways of individual amino acids.	219
12.5	Hereditary enzyme defects in amino acid metabolism	223
12.6	Answers to practice questions.	227
Chapter 13	Hormonal regulation of metabolism.	229
13.1	Hormones that affect energy metabolism	229
13.2	Insulin	230
13.3	Other hormones	240
13.4	Answers to practice questions.	246
Chapter 14	Diabetes mellitus	247
14.1	Introduction	247
14.2	Mechanism of renal glucose loss	248
14.3	Metabolic dysregulation in diabetes mellitus	252
14.4	The role of coxsackieviruses in the pathogenesis of type 1 diabetes	256
14.5	Therapy of diabetes	259
14.6	Answers to practice questions.	267
Chapter 15	Biosynthetic pathways using tetrahydrofolate and vitamin B₁₂	269
15.1	Overview.	269

Contents

15.2	Tetrahydrofolate-mediated carbon transfer reactions.	269
15.3	Folate antimetabolites as antimicrobials	274
15.4	Cobalamin-dependent methylation reactions	275
15.5	Folate and vitamin B ₁₂ deficiency syndromes	280
15.6	Answers to practice questions.	284
Chapter 16	Nucleotide metabolism	287
16.1	Introduction	287
16.2	Overview of metabolic pathways for nucleotides.	290
16.3	Purine synthesis	290
16.4	Utilization of dietary nucleic acids	295
16.5	Purine degradation and salvage pathways	297
16.6	Diseases related to purine degradation	301
16.7	Synthesis and degradation of pyrimidines	305
16.8	Synthesis of deoxyribonucleotides	308
16.9	Nucleotide antimetabolites as anticancer and antiviral drugs.	309
16.10	Answers to practice questions.	318
Chapter 17	Iron and heme metabolism.	321
17.1	Structure and function of heme.	321
17.2	Heme biosynthesis	322
17.3	Disruptions of heme synthesis	327
17.4	Heme degradation	330
17.5	Iron uptake, transport and storage.	335
17.6	Answers to practice questions.	337
Chapter 18	Metabolism of drugs and xenobiotics.	339
18.1	Functional significance	339
18.2	Cytochrome P450 enzymes.	341
18.3	Phase II reactions	346
18.4	Reductive drug metabolism	350
18.5	Anti-tumor drugs that are preferentially activated in tumor cells	351
18.6	Answers to practice questions.	353
Chapter 19	Enzyme and gene therapy of enzyme defects	355
19.1	General considerations	355
19.2	Adenosine deaminase deficiency	359
19.3	Enzyme therapy of lysosomal enzyme defects	363
19.4	Answers to practice questions.	368
Chapter 20	Credits and copyright	371
20.1	Preliminary note.	371
20.2	Individual image credits.	372
20.3	Copyright notice.	374
Bibliography	375

Index 385

Chapter 1

Introduction

1.1 Motivation: Why would you study metabolism?

Long answer: You have a generous and warm character, and you have spent too much time in front of the family TV set. You are therefore determined to become a famous doctor and save many, many lives every hour of the day, without asking anything in compensation but the admiring gazes of the populace, and may be a Rolls Royce. Metabolism is an ever so tiny part of the vast knowledge you have set out to master in order to fulfill your destiny.

Wrong? Alternate long answer: You have the inquisitive mind of a Sherlock Holmes and the financial savvy of a Howard Hughes, and you have determined that soaking medical doctors for damages is the best road to wealth and fame. Understanding the biochemical basis of medicine will help you to stun your audiences in court and grind the defendants and their counsels into the dust.

Wrong again? Then try the short answer: You want to pass your exam.

1.2 Significance of metabolism in medicine

- hereditary enzyme defects
- diabetes, atherosclerosis, gout
- antimetabolites in the chemotherapy of cancers and infections
- inactivation and elimination of xenobiotics and drugs

Notes: Metabolism is a central theme in biochemistry; it keeps cells and organisms alive, by giving them the energy they need to carry on and the building blocks they require for growth and propagation. Metabolism is also an important theme in medicine and pharmacy. Genetic defects of metabolic enzymes, while not among the most common forms of disease, are nevertheless common enough to warrant the routine screening of newborns. Knowledge of the metabolic pathways that

will be affected by a genetic enzyme defect is important to understand its clinical manifestations and to devise strategies for proper diagnosis and treatment.

While metabolic diseases that result from single enzyme defects are comparatively rare, there are metabolic diseases which are much more common, such as diabetes mellitus and gout. Atherosclerosis, which is even more common, is not a purely metabolic disease; however, its initiation and progression are determined to a large extent by metabolic factors. In all these cases, an understanding of the underlying metabolic aspects is the basis for prevention and treatment.

Even with diseases that are not primarily due to metabolic aberrations, metabolic pathways often provide important targets for drug therapy. Cases in point are malignant tumors and autoimmune diseases, which are commonly treated with antimetabolites that disrupt cell proliferation and promote programmed cell death (apoptosis). Antimicrobial drugs often target enzymes in vital metabolic pathways of bacteria and parasites. Conversely, many drugs that target receptors other than enzymes require metabolic modification for activation or elimination.

From all this, it should be quite clear that metabolism matters to all those who pursue a career in medicine or a related field, and who want to truly understand what they are doing. These lecture notes aim to supply this required foundation.

1.3 Catabolic and anabolic reactions

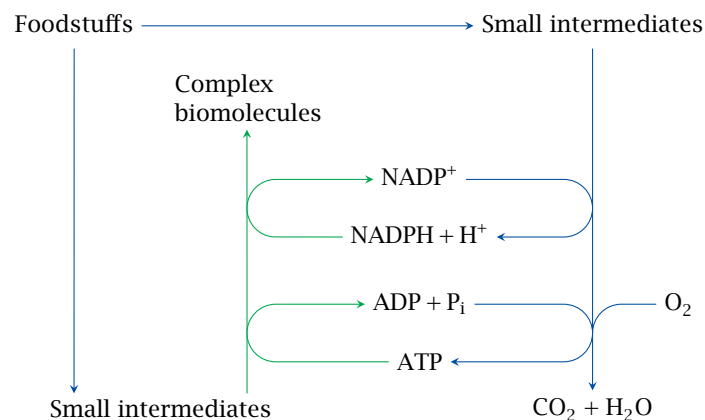

Notes: The metabolism of animals and humans can be divided into *catabolic* reactions (blue arrows) and *anabolic* ones (green). The word “catabolic” means the same as “degradative,” but it is Greek and therefore sounds a whole lot more erudite and scholarly. A large share of the substrates broken down in catabolism are used for producing ATP, the “electric energy” of the cell. Just as electricity can be used to drive just about any household job, ATP is used for almost every energy-requiring task in cell biology. Because of its key role in the life of the cell, we will devote a good deal of space—chapters 3–6—to the metabolic pathways that allow the cell to regenerate ATP.

The word “anabolic” might be translated as “constructive.” Anabolic pathways are the opposite of catabolic ones, that is, they create new biomolecules. They produce small molecules and building blocks that are not sufficiently available

in the food, as well as macromolecules, in particular proteins and nucleic acids. Apart from building blocks and ATP, anabolic pathways also require a good deal of reducing power, mostly in the form of NADPH. One major pathway that supplies NADPH is the hexose monophosphate shunt, which is covered in chapter 9.

Some pathways can function both in a catabolic and an anabolic context. An example is the citric acid cycle, which breaks down acetyl-CoA but also participates in the synthesis of amino acids. Such pathways are sometimes referred to as *amphibolic*.



1.1 Explain the concepts of anabolic, catabolic, and amphibolic pathways.

1.4 Diversity of metabolism: pathways in plants and bacteria

Pathway	Organisms
photosynthesis	plants and cyanobacteria
nitrogen fixation	specialized soil bacteria
oxidation or reduction of inorganic minerals	archaebacteria
acid- and gas-producing fermentations	anaerobic bacteria

Notes: While the scope of this text is mostly restricted to human metabolism, it is useful to take a brief look beyond these confines. There are several mainstream metabolic pathways that occur in all classes of living organisms. A good example is glycolysis, the main pathway of glucose degradation, which is found all the way up from *Escherichia coli* to *Homo sapiens*. On the other hand, some of the metabolic processes in plants or in distinct groups of microbes are quite different from those found in man or animals.

Photosynthesis enables plants to create glucose—and from it, the carbon skeletons of all their other metabolites—from nothing but CO₂ and water. The same is true of blue-green algae or cyanobacteria.¹ Organisms incapable of photosynthesis are *heterotrophic*, which means that they must feed on other organisms. In contrast, photosynthesis makes organisms *autotrophic*, that is, capable of feeding themselves.² Note, however, that plant life also depends on pathways other than photosynthesis. An example is the degradation of starch, which is stored in large amounts in plant seeds such as wheat and rice as well as in bulbs such as potatoes. The pathways of starch utilization employed by plants are analogous to those found in animals.

¹Indeed, cyanobacteria are the prokaryotic precursors of *chloroplasts*, the photosynthetic organelles of plants. Like mitochondria, chloroplasts are endosymbionts of prokaryotic origin and still retain their own genomes and ribosomes.

²Carnivorous plants could be considered both autotrophs and heterotrophs. It seems, however, that plants evolved this lifestyle mostly to secure a supply of organic nitrogen rather than of carbon.

Nitrogen fixation, that is, the reduction of atmospheric nitrogen (N_2) to ammonia (NH_3), is performed by the bacterium *Sinorhizobium meliloti* and related soil bacteria. All other living organisms require nitrogen in already reduced form, and therefore depend on these bacteria. The word *Rhizobium*—the former first name of this bacterium—means “living on roots”. *Sinorhizobium meliloti* thrives on the roots of plants, which take up the surplus ammonia supplied by the bacteria and utilize it for synthesizing their own amino acids; the plants, in turn, provide the bacteria with a nutrient-rich environment. This symbiotic process is common with legumes such as alfalfa, soy beans, and peas. Including these plants in crop rotation schemes helps to keep the soil supplied with reduced nitrogen. Alternatively, the nitrogen fixation bottleneck can be bypassed altogether by supplying reduced nitrogen with chemical fertilizers.³

Some *archaebacteria*, which live in exotic environments such as submarine volcanic hot springs, have developed correspondingly exotic metabolic pathways. For example, some of these organisms are capable of extracting energy from the oxidation of iron or the reduction of sulfur.

While all these pathways are certainly very interesting, we will not consider them any further in these notes. Instead, we will confine the discussion to the major metabolic pathways that occur in the human body. We will also relate these pathways to human health and disease, and to some of the therapeutic strategies that have been developed for metabolic diseases.

In the remainder of this chapter, we will start with a broad overview of foodstuffs and their digestion and uptake in the intestinal organs. This will provide some important context for the detailed discussion of metabolic pathways in the subsequent chapters.



1.2 In the metabolism of heterotrophs like *Homo sapiens*, what are the ultimate sources of organic carbon and of reduced nitrogen?

1.5 Types of foodstuffs

- carbohydrates
- protein
- fat
- nucleic acids

³Until the early 20th century, the only practical source of nitrogen fertilizer was *guano*, which is accumulated, dried bird poop. It is found in large deposits on cliffs and islands off the South American west coast, and clippers ferrying the precious stuff used to go back and forth between Chile or Peru and Europe or North America.

In 1909, Haber and Bosch devised a synthetic method for producing nitrogen fertilizer, as well as nitrogen-based explosives. In this process, the reaction $N_2 + 3 H_2 \rightarrow 2 NH_3$ is induced by brute force: a mixture of the two gases is compressed to very high pressures and heated to high temperature in the presence of a metal catalyst. The method has been in use ever since for producing nitrogen fertilizer. Among all the great inventions that have propelled the growth of the world population, the Haber-Bosch process likely is the single most important one.

Notes: The three major categories of foodstuffs relevant to human metabolism are named on every box of cereal or cup of yogurt; and in case you do not remember them, I suggest you run out right now to buy some such scholarly piece of grocery; dollar for dollar, its educational value might exceed that of your attendance of this class.

The fourth item in the list above, nucleic acids, could as well have been subsumed under carbohydrates, since only the ribose and deoxyribose contained in them have significant nutrient value. The pathways that would allow the reuse of the bases for nucleotide and nucleic acid synthesis exist in principle, but experimental studies indicate that ingested bases are mostly degraded and excreted (see section 16.4).

1.5.1 Breakdown of foodstuffs: Overview

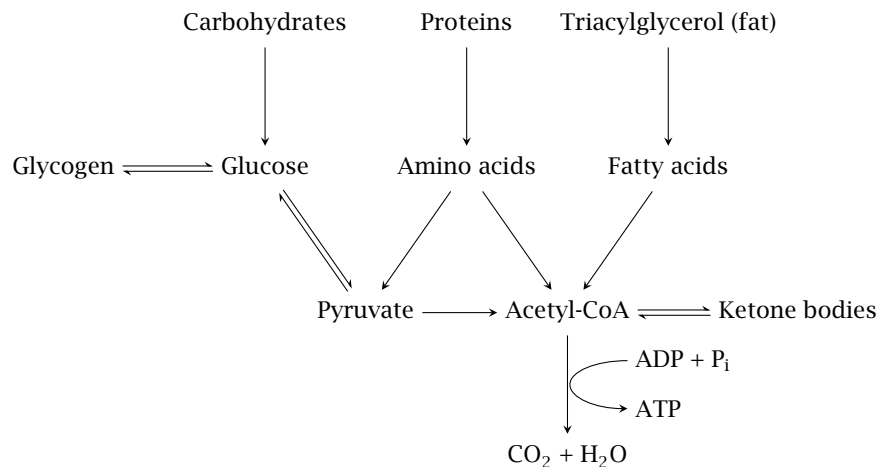

Notes: In the first stage of their utilization, all foodstuffs are split into their building blocks; this happens mostly during digestion in the small intestine. After the building blocks—mainly glucose, amino acids, and fatty acids—have been taken up and distributed through the blood stream, complete breakdown to CO_2 and H_2O proceeds intracellularly via pyruvate and acetyl-CoA, which function as central hubs of foodstuff utilization.

Glucose can transiently be stored in polymeric form as glycogen, which evens out the peaks and valleys of glucose supply during the day. If required, additional glucose can be produced via gluconeogenesis from amino acids whose degradation yields pyruvate.

When other forms of substrate carbon are in short supply, fatty acids—either taken up with the food or released from fat tissue—can be converted via acetyl-CoA to *ketone bodies*, which represent a more water-soluble transport form of carbon than the fatty acids themselves.

This slide is of course simplified and contains several approximations. For example, some carbohydrates do not directly yield glucose upon depolymerization; these may then be converted to glucose through dedicated adapter pathways. Similarly, the breakdown of some amino acids does not yield pyruvate or acetyl-CoA

but instead produces citric cycle intermediates. Like pyruvate, these intermediates can also be converted to glucose if needed.



1.3 Name the three major products of foodstuff digestion in the small intestine, and the two central hubs of cellular foodstuff utilization.

1.6 The digestive system

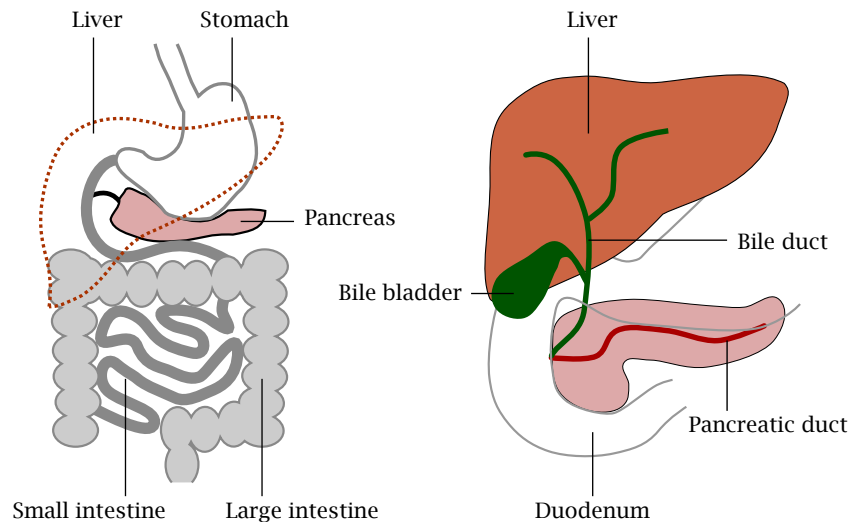

Notes: The digestive system contains the intestinal hollow organs, that is, the esophagus, stomach, small and large intestine. In addition, it also comprises the pancreas and the liver, both of which arise through budding and outgrowth from the primordial intestine during embryonic development.

1.6.1 Intestinal organs: functional overview

Organ	Function
stomach	killing of microbes contained in the food; protein denaturation
small intestine	breakdown of macromolecules to small molecules, uptake of the latter
large intestine	fluid and ion reuptake
pancreas	production of digestive enzymes and of hormones
liver	production of bile; metabolic homeostasis

Notes: The mucous membrane of the stomach produces gastric acid, HCl, which denatures proteins and kills microbes contained in the food. The pancreas supplies most of the digestive enzymes, whereas the liver provides bile acids, which are

essential for the solubilization of fat. The bile and the pancreatic juice also contain large amounts of sodium bicarbonate, which neutralizes the gastric acid; the milieu inside the small intestine is slightly alkaline.⁴

The digestive enzymes secreted by the pancreas into the gut do most of the work involved in digestion of ingested foodstuffs. Therefore, depolymerization of foodstuff macromolecules occurs extracellularly.⁵



1.4 Name the digestive organs and summarize their functions.

1.6.2 The portal circulation

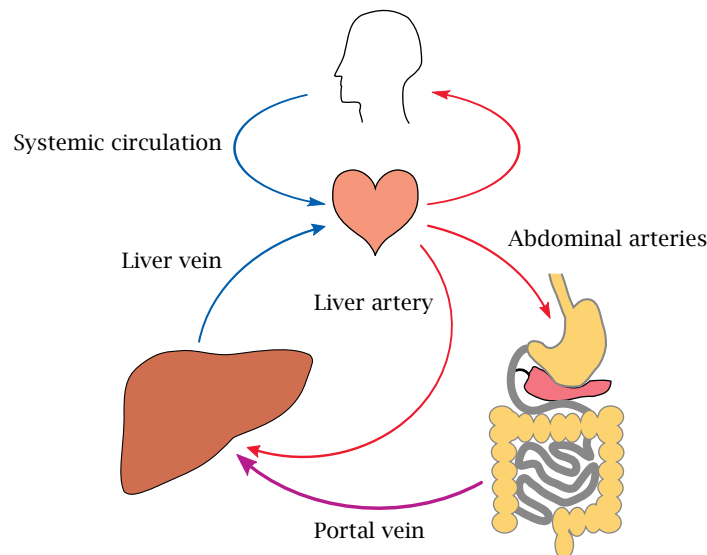

Notes: Upon uptake, most solutes will be exported on the other side of the mucosal cells and then find themselves in the blood stream. A peculiarity of the intestines is that all blood drained from them is first passed through the liver before being released into the general circulation. This serves a twofold purpose:

1. It gives the liver a chance to take excess amounts of substrates—glucose, amino acids—out of circulation and to store and process them. This serves to

⁴The bile duct and the pancreatic duct join the *duodenum*, that is, the uppermost part of the small intestine, at the same site (termed the *papilla duodeni major*). Bile stones traveling down the bile duct may get stuck at this orifice and obstruct both secretory ducts. On top of bile colics, this may then result in *acute pancreatitis*, in which the backed-up pancreatic enzymes start digesting the pancreas itself. This is both exceedingly painful and a major, acutely life-threatening calamity.

⁵Extracellular digestion is employed by most organisms. Even bacteria secrete digestive enzymes and take up substrates only at the stage of the monomeric breakdown products. Why is that so?

An obvious answer is that there are no transport mechanisms for the uptake of macromolecules across the cell wall. While that is true, there is a deeper reason—taking up macromolecules in a non-specific way would open the door for all kinds of viruses and Trojan horses. Extracellular digestion constitutes a firewall that excludes hazardous macromolecules.

Exceptions to the rule above are amoebas, which ingest not only macromolecules but even whole bacteria. However, the ingested bacteria remain confined within membrane vesicles called phagosomes, which get swiftly flooded with acid as well as aggressive chemicals and enzymes that kill and degrade the bacteria. The same occurs in our phagocytes, which are an essential part of our immune system (see slide 9.3.7).

maintain stable blood nutrient concentrations, which is important for the well-being of the more sensitive and fastidious cells in the other organs.

2. The bacteria that reside in the large intestine produce ammonia and other toxic metabolites, which are cleared by the liver. In patients with liver failure, these toxic metabolites spill over into the systemic circulation, which among other things will lead to disturbances of cerebral function. The detoxifying activity of the liver also affects many drugs; the inactivation of drugs by the liver immediately following intestinal uptake is known as the *first pass effect* (see slide 18.1.3).

The large vein that drains all the blood from the intestines and channels it to the liver is the *portal vein*; together with its tributaries, it forms the *portal circulation*. Aside from the intestines, the pancreas and the spleen also have their blood drained into the portal vein.

In addition to the blood carried by the portal vein, which is at least partially oxygen-depleted, the liver also receives a direct supply of oxygen-rich blood through the liver artery. The two feeds branch out in parallel throughout the liver and eventually merge within the tissue of the liver lobules (see below), from which all blood is then drained toward the venous side of the general circulation.



1.5 What is the portal circulation, and which organs participate in it?

1.6.3 Liver tissue structure

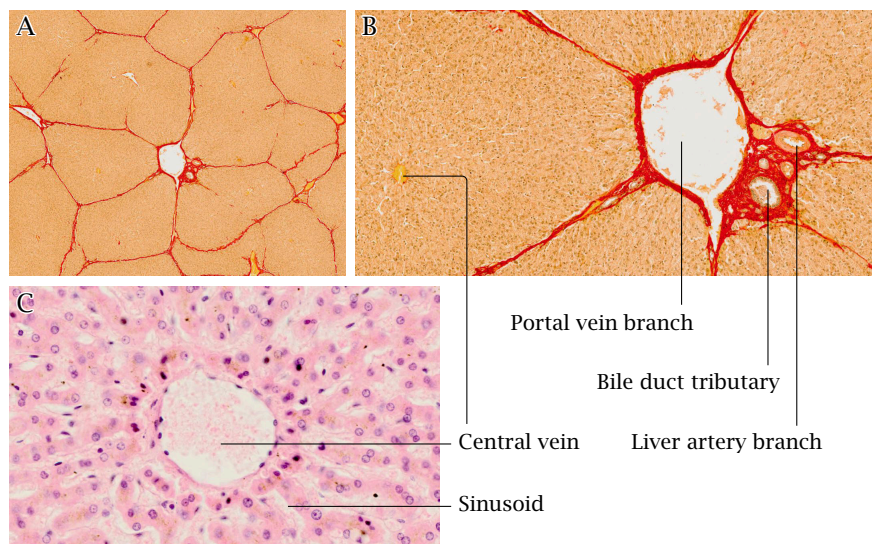

Notes: The liver has a peculiar tissue structure that is optimized for rapid and efficient solute exchange between the percolating blood and the liver cells. While in the tissues of most organs the blood is contained in capillaries with clearly defined boundaries and walls, the liver has a sponge-like structure that permits direct contact of the blood plasma with the liver cells.

A: The liver is organized into functional units called *lobules*, which measure ~2 mm across. In this tissue cross section, several lobules are demarcated by strands of connective tissue that are stained red.

B: Blood from branches of the portal vein and of the liver artery percolates each lobule and flows towards its central vein, which drains it into the general circulation. Bile duct branches drain bile from each lobule toward the intestine.

C: Higher magnification shows the sponge-like structure of the liver tissue. In life, blood flows through the sinusoids, which in this tissue section are visible as the voids between strands of liver cells. The intimate contact of the liver tissue with the percolating blood maximizes the rate of solute exchange between cells and blood plasma.

1.6.4 Blood flow and bile flow within the liver lobule

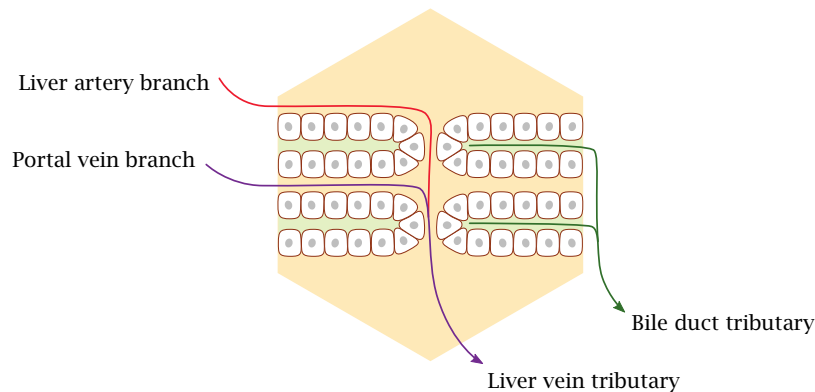

Notes: The epithelial cells in each liver lobule are arranged in parallel layers. The basolateral side of each cell faces the blood-filled sinusoid, while the apical side faces a bile duct tributary. These finest, uppermost bile duct branches are so thin that they can only be visualized using special histological techniques or by electron microscopy.

The liver cells extract solutes from the blood, modify them, and export them either back into the bloodstream or directly into the bile. This process is very efficient; with some solutes, extraction and modification is almost complete during a single pass through the liver.



1.6 Liver tissue is organized into functional units. What is the name of such a unit, and what does its function entail?

1.6.5 The stomach: functions of gastric acid

- HCl, pH 1-2
- secreted by specialized cells in the mucous membrane (parietal cells)
- kills germs contained in food; patients with lack of gastric acid are at increased risk of intestinal infection
- denatures food proteins and makes them accessible to cleavage by proteases

Notes: The activity of the HCl-secreting parietal cells is controlled by histamine H_2 receptors; accordingly, H_2 receptor blockers such as ranitidine are effective in

the suppression of acid secretion. Another class of drugs used to the same end inhibit the ATP-dependent proton pump that actually brings about the secretion of acid.

Once upon a time, excessive secretion of gastric acid was considered the main cause of gastric and duodenal ulcers. We now know that the true cause of ulcers is the bacterium *Helicobacter pylori*, and accordingly we treat this disease with antibiotics. Nevertheless, inhibitors of gastric acid secretion continue to be used as well, since gastric acid aggravates the ulcers and disturbs their healing.

Individuals that lack gastric acid, due either to a disease or to drugs that inhibit acid secretion, are more susceptible to orally contracted infectious diseases such as cholera, *Salmonella* enterocolitis, and intestinal tuberculosis.

1.6.6 Gastric acid and pepsin in protein digestion

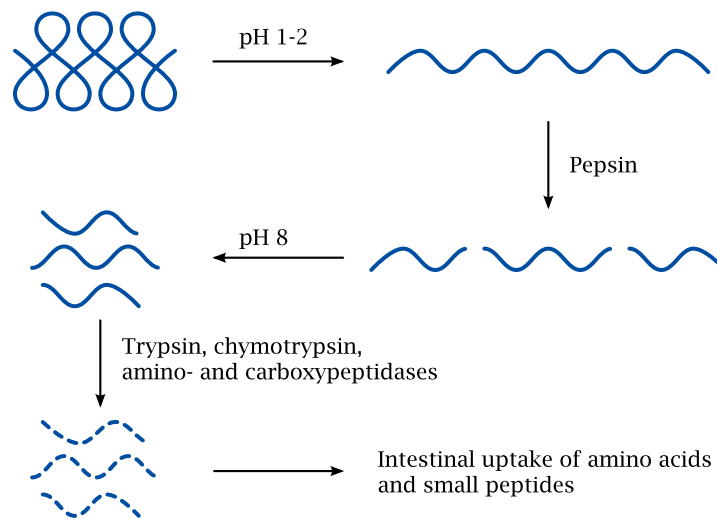

Notes: At very low pH, a protein molecule will become extensively protonated and thereby accumulate positive charges. The mutual repulsion of these positive charges will destabilize the protein and cause it to unfold. In this unfolded form, all the peptide bonds become exposed and accessible to proteases.

Protein digestion is initiated right away in the stomach by the protease pepsin, which is produced by the stomach mucous membrane. The peptide fragments will no longer refold, even after the pH has reverted to slightly above neutral values in the small intestine. Peptide digestion can therefore continue and be completed by the pancreatic proteases and peptidases encountered there.

While most proteins will be unfolded by gastric acid, there are exceptions; an obvious and important one is pepsin itself. Similarly, the coat proteins of many pathogenic viruses, for example poliovirus or hepatitis A virus, are fairly resistant to gastric acid as well. These viruses are therefore able to traverse the stomach intact and then infect the mucous membranes of the intestine.



1.7 What is the physiological function of gastric acid?

1.6.7 Function of the exocrine pancreas

- secretion of digestive enzymes
 - amylase
 - proteases, peptidases
 - lipases
 - DNase, RNase
- secretion of bicarbonate to neutralize gastric acid

Notes: The exocrine pancreas produces all the major depolymerizing enzymes for digestion. Therefore, if the pancreas is not working properly—often as a result of acute or chronic pancreatitis—maldigestion of all types of foodstuff results.

When the acidified food passes from the stomach to the duodenum, it is neutralized by copious amounts of bicarbonate that is contained in the pancreatic juice, the bile, and the secretions of gland tissue embedded in the mucous membranes of the duodenum itself. Accordingly, the pH optima of the pancreatic enzymes are in the neutral to slightly alkaline range.⁶

1.6.8 Roles of bile in digestion

- Bile acids solubilize triacylglycerol and make it accessible to pancreatic lipase
- Bicarbonate contributes to the neutralization of gastric acid

Notes: Among its many other functions, the liver also serves as an exocrine gland.⁷ The digestive juice secreted by the liver is known as bile and is rich in bile acids, which are important in solubilizing fat so as to render it accessible to enzymatic cleavage by pancreatic lipase.⁸ Bile that is not needed immediately is diverted to the bile bladder, where it is concentrated and stored. In the bile concentrate, solutes may exceed their solubility limit and start to precipitate or crystallize within the bile bladder, forming gallstones. This occurs most commonly with cholesterol and bilirubin, both of which are excreted with the bile (see chapters 11 and 17, respectively).

Like the pancreatic juice, the bile is also rich in sodium bicarbonate and contributes to the neutralization of the acidified stomach content as it enters the duodenum. Unlike the pancreatic juice, however, the bile does not contain digestive enzymes. Disruption of bile secretion will therefore cause deficient digestion of fat only, but not of proteins or carbohydrates.

⁶If you already have some lab experience, you may have treated cells with trypsin or fragmented DNA with pancreatic DNase, and may remember that these enzymes work best at pH 7.5–8.

⁷An *exocrine* gland secretes outwardly; this definition includes secretions into the digestive tract. An *endocrine* gland secretes into the bloodstream. The products of endocrine glands are invariably hormones.

⁸Bile acids solubilize fat (triacylglycerol) effectively because they are detergents with a high critical micellar concentration (see slide 10.2.2). For the same reason, they are also useful for removing tough stains from your laundry.

The greater share of the bile acids is taken up again in the lowermost section of the small intestine, that is, the *terminal ileum*. Via the portal vein, they return to the liver, where they are extracted and again secreted.



1.8 Describe and distinguish the roles of pancreatic juice and of bile in the digestion of foodstuffs.

1.6.9 The small intestine

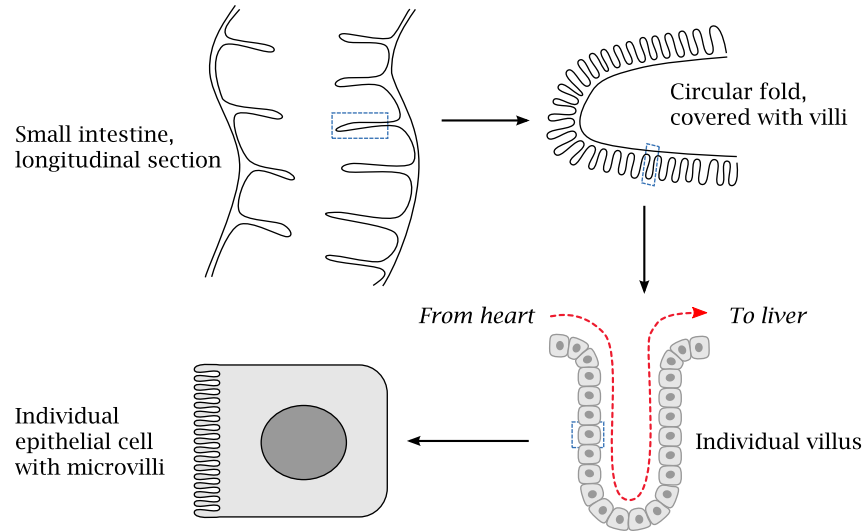

Notes: The small intestine comprises, from top to bottom, the duodenum, the jejunum, and the ileum. Small substrate molecules produced by the digestive enzymes within the gut are taken up by active transport across the mucous membrane of the small intestine. The capacity for substrate uptake is obviously related to the surface area. Accordingly, the mucous membrane is highly folded so as to maximize the surface available for substrate uptake. This slide illustrates how surface maximization is realized all hierarchical levels of tissue and cell structure.

The inner surface of the small intestine has circular folds, which in turn are covered by villi. The individual epithelial cells that cover the villi are, on their luminal surfaces, covered by microvilli. The blood that perfuses the villi of the intestinal mucosa (red arrow) and carries away the absorbed nutrients is drained toward the liver via the portal vein (see slide 1.6.2).

1.6.10 Microscopic structure of the small intestine

Notes: These microscopic pictures of the mucous membrane illustrate the villi and microvilli in the small intestine. The left panel shows a low-power view of a section across a circular fold, which is covered by a dense mane of villi. The right panel shows an electron-microscopic image of microvilli atop an individual epithelial cell.

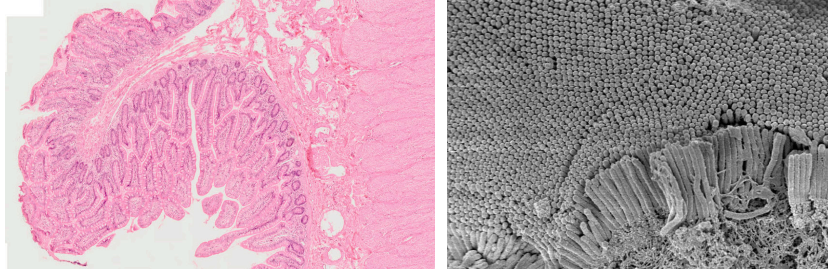

1.6.11 Amylose and amylopectin are polymers of α -D-glucose

Notes: As an example of foodstuff processing in the small intestine, let us take a quick look at the digestion of starch. The constituents of starch are amylose and amylopectin. Amylose (black) is an unbranched $\alpha(1\rightarrow4)$ polymer of D-glucose. Amylopectin additionally contains branches (blue) that are attached through $\alpha(1\rightarrow6)$ -glycosidic bonds.

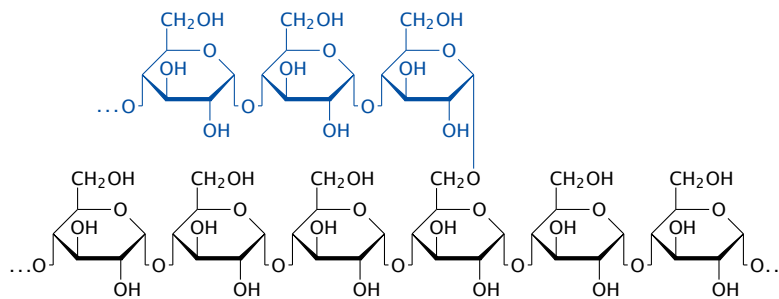

1.6.12 Amylase breaks down starch to maltose and isomaltose

Notes: In the small intestine, amylose and amylopectin are broken down by pancreatic amylase. The main product is maltose, which is produced from amylose and from the linear $\alpha(1\rightarrow4)$ stretches of amylopectin. Isomaltose originates from the $\alpha(1\rightarrow6)$ branching points of amylopectin.

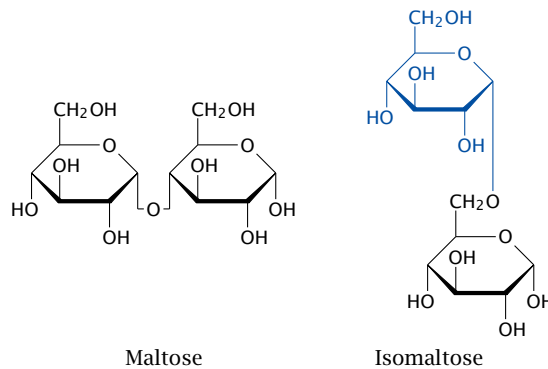

The two disaccharides are cleaved to glucose by maltase and isomaltase, respectively. These enzymes are anchored to the surfaces of the epithelial cells of the intestinal mucosa. The same epithelial cells then take up glucose by active transport (see next slide).

1.6.13 Mechanism of glucose uptake from the gut

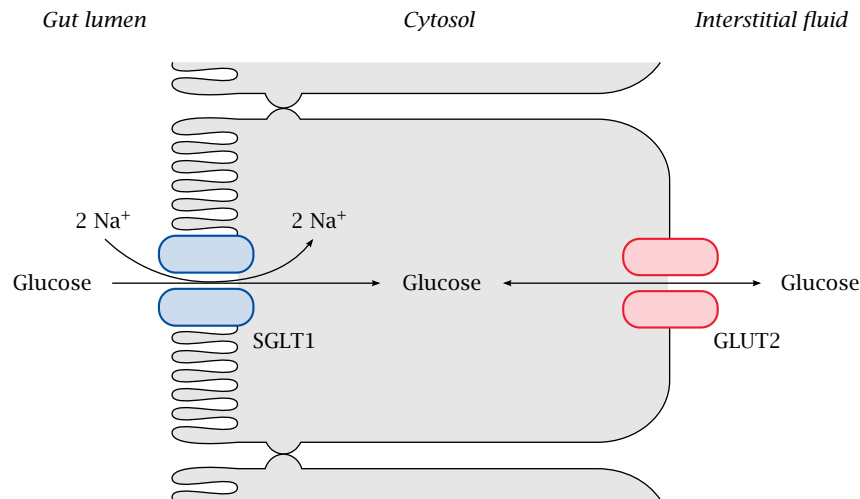

Notes: After digestion, the metabolites have to be taken up by the epithelial cells at the inner surface of the small intestine. In most cases, nutrients are taken up by *active transport*, which can transport solutes energetically uphill, that is, against their concentration gradients. Active transport is necessary to ensure the quantitative uptake of the nutrients.

In the case of glucose, active transport is driven by the simultaneous uptake of two sodium ions per molecule of glucose. This coupling is effected by the SGLT1 transporter. Sodium (secreted as bicarbonate) is plentiful in the gut lumen, while its concentration is low inside the cells. An additional driving force is the membrane potential: the cytosol is electrically negative relative to the extracellular space. The uphill transport of glucose is therefore driven by the simultaneous downhill movement of sodium. Similar transporters exist for other sugars, e.g. galactose, and for amino acids and nucleosides.

On the basolateral side of the intestinal epithelia—that is, the side that faces the surrounding tissue, not the gut lumen—glucose is released into the extracellular space, from where it can freely diffuse into the bloodstream to reach the liver. The export from the epithelial cells is mediated by GLUT transporters. These operate by passive transport, also known as facilitated diffusion (see slide 3.5.1). In other organs, GLUT transporters mediate the *uptake* of glucose. GLUT transporters are found in all cells of the body (see section 3.5).

 **1.9** Explain how starch is processed in the small intestine.

 **1.10** Which forces affect the transport of glucose by the SGLT?

1.6.14 The large intestine

- Anaerobic milieu—99% of all bacteria in the large intestine are strict anaerobes
- Bacteria degrade non-utilized foodstuffs, reducing osmotic activity of gut content
- Mucous membrane recovers water and electrolytes
- Bacterial metabolism releases potentially toxic products (e.g. ammonia), which are taken up and inactivated by the liver

Notes: The cumulative volume of the fluids secreted into the stomach and the small intestine exceeds four liters per day. It falls to the large intestine to recover most of that fluid. This inevitably slows down the transport of the gut contents, which in turn will cause them to be overgrown with bacteria.⁹ The bacterial flora is mostly harmless, though, and it even helps with breaking down undigested remnants in the gut content and thereby freeing up the water bound osmotically by them. They produce some vitamins, too, for example folic acid, but also some potentially toxic substances such as amines and ammonia. The latter are taken up and dealt with by the liver.

1.7 Answers to practice questions

1.1: Anabolic pathways create new biomolecules, usually complex ones, from simple precursors. Catabolic pathways break down biomolecules in order to produce ATP, NADPH, or building blocks for anabolic reactions. Amphibolic pathways can function in both catabolic and anabolic processes.

1.2: Organic carbon is derived from photosynthesis in plants, whereas reduced nitrogen is derived from nitrogen fixation in soil bacteria.

1.3: The major products of digestion are glucose, amino acids, and fatty acids, which are released from carbohydrates, proteins, and triacylglycerol, respectively. Utilization of these products proceeds via pyruvate and acetyl-CoA.

1.4: See table in slide 1.6.1.

1.5: The portal circulation drains venous blood from the stomach, intestines, pancreas, and spleen into the portal vein. The blood then enters the liver, where it is distributed and processed before being drained again into the systemic circulation.

1.6: The functional unit of the liver is the lobule. It receives blood from branches of both the liver artery and the portal vein, which flows through the lobule's sinusoids toward its central vein. The epithelial cells that line the sinusoids extract and process solutes from the blood, some of which they secrete into bile duct tributaries.

1.7: Gastric acid denatures proteins, which initiates the digestion of food proteins and also helps to inactivate ingested microbes.

⁹The party trick that prevents bacterial colonization of our other hollow organs is to discharge and replace the fluids more rapidly than the bacteria can grow. Accumulation and stasis of fluid invariably leads to bacterial overgrowth and often infection; examples are recurrent urinary tract infections when bladder function is impaired, and the respiratory infections facilitated by viscous, slowly flowing bronchial secretions in patients with cystic fibrosis.

1.8: Pancreatic juice supplies the depolymerizing enzymes for all foodstuffs, whereas bile supplies no enzymes but contains bile acids, which solubilize fat but are not important in the processing of other foodstuffs. Both pancreatic juice and bile contain bicarbonate, which serves to neutralize gastric acid.

1.9: Starch is broken down by pancreatic amylase to maltose and isomaltose, both of which are cleaved to glucose by cognate disaccharidases located at the surface of intestinal epithelial cells. The epithelia take up glucose by sodium cotransport and release it at the basolateral side through facilitated diffusion.

1.10: SGLT mediates the uptake of glucose into cells by sodium co-transport. The transport is driven by three forces: (1) The concentration gradient of glucose itself—glucose can be higher or lower outside the cell than inside, favouring or disfavoring uptake (2) The concentration gradient for sodium; $[\text{Na}^+]$ is always higher outside the cell, which favors co-transport (3) The membrane potential, which is always negative inside in non-excitabile cells such as those containing SGLT transporters; this also favors uptake.

Chapter 2

Refresher

2.1 Preliminary note

This chapter reviews some key concepts from second year biochemistry. Feel free to skip it if you remember a thing or two from that distant past.

2.2 How enzymes work: active sites and catalytic mechanisms

As with all proteins, the activity of enzymes depends on the precise arrangement and interaction of their amino acid residues and side chains. A straightforward example of this is chymotrypsin. Chymotrypsin is one of the major proteases in the human digestive tract, where its job is to knock down large protein molecules into small peptides that are then further processed by peptidases.

2.2.1 The “catalytic triad” in the active site of chymotrypsin

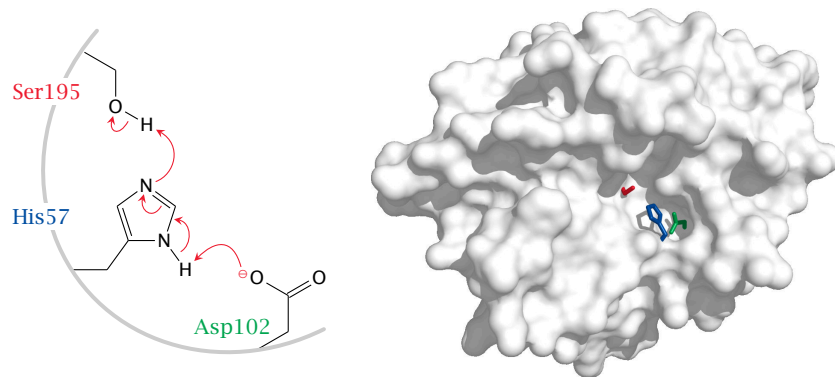

Notes: The active site of chymotrypsin contains aspartate 102, histidine 57, and serine 195. The aspartate and the histidine cooperate to deprotonate the hydroxyl

group of the serine, which then attacks the substrate peptide bond (see next slide). Molecular structure rendered from [1afq.pdb](#).

The Asp-His-Ser motif is very common among proteases and esterases, so much so that it is often simply referred to as the *catalytic triad*. For example, the protease trypsin and several lipases that occur in human metabolism also have this motif and share the same mechanism of catalysis. Other enzymes, for example the *proteasome*, may contain glutamic acid instead of aspartic acid, or threonine instead of serine. These variants still contain the same functional groups and work the same way.

2.2.2 The catalytic mechanism of chymotrypsin

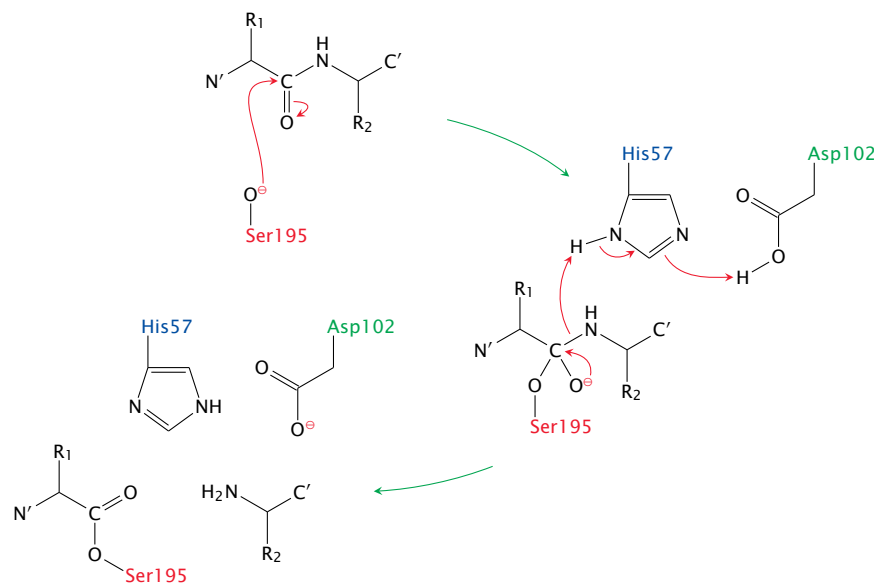

Notes: After it has been deprotonated by aspartate and histidine, the serine performs a nucleophilic attack on the carbonyl group of the substrate peptide bond. This produces a short-lived tetrahedral intermediate that gives way when the C-terminal peptide fragment leaves; the N-terminal fragment remains covalently attached to the serine. This state of affairs, which is shown as the final stage in this slide, is reached after the first half of the reaction.

In the second half reaction, which is not shown, the aspartate and histidine residues deprotonate a water molecule, and the hydroxide ion thus formed then bounces the N-terminal peptide fragment off the serine, again by nucleophilic attack on the carbonyl group. The bond undergoing cleavage at this stage is an ester, which yields more readily than the amide bond in the first stage.



2.1 What is the catalytic triad, and how does it work?

2.2.3 Many enzymes require coenzymes

With chymotrypsin, the enzyme molecule and its amino acid side chains supply all the necessary tools for catalysis. In contrast, many other enzyme molecules require *coenzymes* for their activity. For example, alanine aminotransferase, which transfers the α -amino group from alanine to α -ketoglutarate, contains the coenzyme pyridoxal phosphate within its active site. In the reaction, the coenzyme cooperates with a lysine residue that is part of the enzyme itself (see slide 12.2.1).

Most enzyme molecules have just one active site, or, in case they are multimeric, one active site per subunit. However, there are exceptions: Fatty acid synthase has as many as six different active sites on each subunit (see slide 10.5.2). Pyruvate dehydrogenase is a multienzyme complex that contains one active site on each subunit, but it combines three different types of subunits, each with a different coenzyme and catalytic function, into one functional assembly (see slide 5.2.2).

2.2.4 IUBMB classification of enzymes

Enzyme class	Catalyzed reactions
oxidoreductases	catalyze redox reactions, frequently involving one of the coenzymes NAD^+ , NADP^+ , or FAD
transferases	transfer functional groups between metabolites, e.g. a phosphate from ATP to a sugar hydroxyl
hydrolases	catalyze hydrolysis reactions, such as those involved in the digestion of foodstuffs
lyases	perform elimination reactions that result in the formation of double bonds
isomerases	facilitate the interconversion of isomers
ligases	form new covalent bonds at the expense of ATP hydrolysis

Notes: The IUBMB nomenclature divides all enzymes into six classes according to the reactions they catalyze. Within each of these main classes, there are subclasses and sub-sub classes, which reflect differences in substrate usage and mechanism of catalysis. The categories at all three hierarchical levels are assigned unique numbers, and each individual enzyme receives a number as well that is unique within its sub-sub class. An enzyme can therefore be unequivocally identified by a dot-separated identifier containing four numbers overall. This identifier is prefixed with the letters “EC” (for “Enzyme Commission”). Fittingly, the identifier EC 1.1.1.1 goes to the single most important enzyme in student lifestyle—namely, alcohol dehydrogenase, or, as IUBMB puts it, *alcohol:NAD oxidoreductase*.¹ A list

¹This commendable enzyme, residing in the liver, degrades ethanol, and without it, some of us might be drunk all the time!

of all the enzyme activities recorded by the IUBMB classification is available at chem.qmul.ac.uk/iubmb.

The IUBMB scheme also assigns explicit names, which are often rather formidable such as this one for the enzyme otherwise known as transketolase (see chapter 9): *sedoheptulose-7-phosphate: D-glyceraldehyde-3-phosphate glycolaldehydetransferase*. Reciting this name three times in quick succession will cure any stammer; however, we will forgo this benefit and use the traditional shorter names in this text.



2.2 Why does alcohol dehydrogenase have the IUBMB identifier EC 1.1.1.1?

2.3 Energetics of enzyme-catalyzed reactions

With each enzymatic reaction, as with any other chemical reaction, energy comes in with these two questions: 1) will the reaction proceed at all in the desired direction, and 2) if it does, will it proceed at a sufficient rate?

The first question is decided by the free energy of the reaction, ΔG ; a reaction will go forward if, and only if, the associated ΔG is negative. The second question depends on the activation energy, ΔG^* , which forms a barrier between the initial state and the final state of the reactants. The very short-lived, energy-rich state at the top of this barrier is called the *transition state*. Enzymes can substantially lower the activation energy ΔG^* and thus accelerate reactions, but they cannot change the overall free energy ΔG —and therefore, the direction or equilibrium—of the reaction.

2.3.1 A simile: the Walchensee–Kochelsee hydroelectric power system

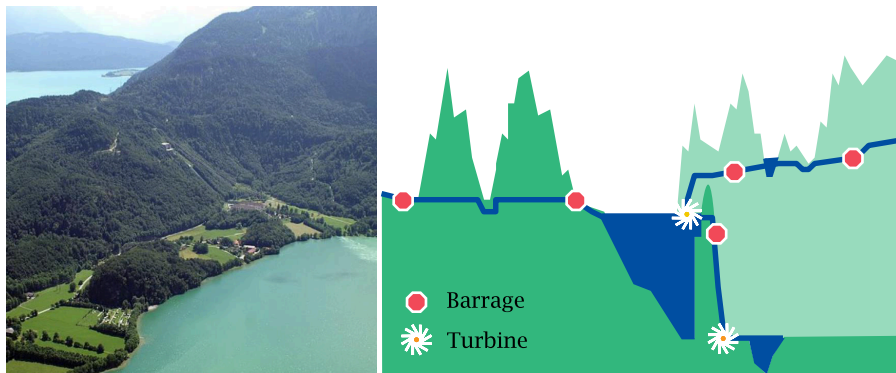

Notes: The different roles of ΔG and ΔG^* in biochemical reactions can be illustrated with a simile. The slide shows two natural lakes in the German Alps. The Walchensee is situated 200 m above the Kochelsee. A conduit was dug across the barrier between these two lakes to make the water flow downhill and drive a hydroelectric turbine. Additional tunnels drain other lakes and rivers to enhance the supply of water to the Walchensee.

2.3.2 Analogies in the simile

Hydroelectric system	Metabolic pathway
altitude	energy
difference in altitude between lakes	energy difference between metabolites (ΔG)
height of ridge between lakes	ΔG^* of uncatalyzed reaction
tunnels	enzymes
tunnel barrages	regulatory switches of enzymes

Notes: An enzyme facilitates the interconversion of metabolites by creating an energetic “tunnel” across the energy barrier between them. Like a water conduit, an enzyme can facilitate the flow. However, it cannot change its direction, which will depend solely on the difference in altitude (ΔG).

In the hydro-electric system, tunnels can be opened or shuttered by barrages to accommodate variations in the amount of rainfall or in energy demand. Similarly, enzymes have regulatory switches that allow for adjustments in the flow rate through metabolic pathways in keeping with changing physiological needs.

2.3.3 Discrepancies in the simile

Hydroelectric system	Metabolic pathway
all tunnels work the same way	enzymes have different catalytic mechanisms
potential energy determined by one parameter: altitude	free energy of metabolites depends on two parameters: ΔH and ΔS
water always collects at the bottom	molecules partition between lower and higher energy levels

Notes: Our simile illustrates some, but not all aspects of enzyme reactions. For example, all tunnels are alike; in contrast, each enzyme needs a specific “trick” or catalytic mechanism in order to accomplish the specific task at hand. Investigating the catalytic mechanisms of individual enzymes is an important and fascinating aspect of biochemistry.

Another difference concerns the energetic states. The energy difference between the two lakes is completely determined by their difference in altitude. However, the difference in free energy (ΔG) between two metabolites also depends on entropy, which is determined by their concentrations. Reactions are therefore subject to equilibrium; states with higher ΔH are less populated, but never totally unoccupied. The equilibrium is given by this relationship:

$$\frac{n_1}{n_2} = e^{-\frac{\Delta G}{RT}} \quad (2.1)$$

where n_1 and n_2 represent the numbers of molecules in the high and low energy states, respectively. (R is the gas constant, whereas T is the absolute temperature.)

Equation 2.1 applies to the occupancy of the initial and the final states of a reaction. It also applies to the distribution of molecules between the initial state and the transition state of a reaction. The tendency of molecules to spontaneously populate states of higher energy explains that chemical reactions will occur at all, even though the energy level of the transition state is always higher than those of the initial and final states. However, the higher the activation energy, the more rarefied the transition state will become. The number of molecules that can first climb the barrier and then hop down on the other side thus becomes smaller, and the reaction slower with increasing activation energy. Enzymes—and catalysts in general—create transition states that are lower in energy and therefore more populated than the uncatalyzed ones.



2.3 Explain the different meanings and implications of ΔG and ΔG^* for the equilibrium and rate of a chemical reaction, and the effect of an enzyme on each.

2.4 The role of ATP in enzyme-catalyzed reactions

As we have seen, enzymes alone cannot drive endergonic reactions forward; however, an enzyme may couple an intrinsically endergonic reaction to an exergonic one, so as to make the overall reaction exergonic also. Most commonly, the auxiliary exergonic reaction consists in the hydrolysis of ATP to ADP or AMP. While this use of ATP pervades all of enzymology, it is important to understand that there is no equally general chemical mechanism of ATP utilization: each enzyme needs to find its own way of actually, chemically linking ATP hydrolysis to the reaction which it needs to drive.

2.4.1 The catalytic mechanism of glutamine synthetase

Notes: As an example, this slide shows how glutamine synthetase uses ATP to produce glutamine from glutamate and ammonia.

While the net turnover of ATP is hydrolysis, the ATP molecule isn't hydrolyzed directly. Instead, the phosphate group is first transferred to the substrate to create an intermediate product, glutamyl-5-phosphate. In this mixed anhydride, the phosphate group makes a very good leaving group, which facilitates its subsequent substitution by ammonia. Therefore, the utilization of ATP is a central part of this enzyme's catalytic mechanism. We will see some more examples of ATP usage in enzyme catalysis in the remainder of this notes.



2.4 How does ATP utilization facilitate the glutamine synthetase reaction?

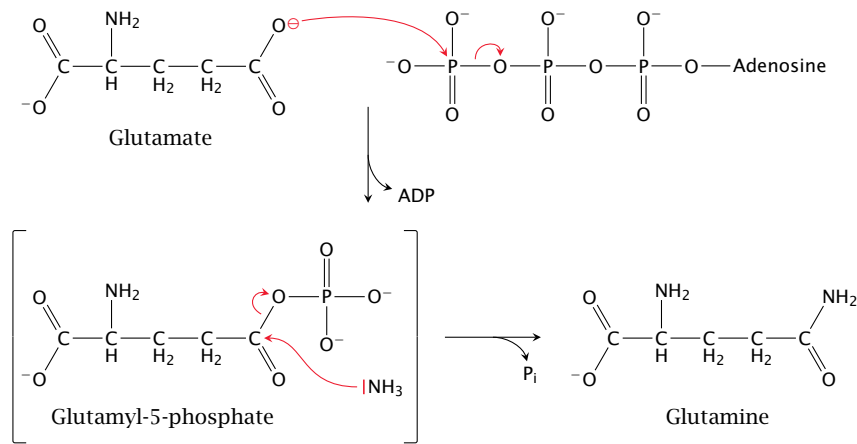

2.5 Regulation of enzyme activity

Just as a hydroelectric power station has to adjust to variations in water supply and demand for electricity, metabolic pathways and enzymes must adapt to changes in substrate availability and in demand for their products. The activities of enzymes are regulated at different levels. Activating gene expression will increase the abundance of an enzyme, whereas activation of protein breakdown will decrease it. In addition, there are mechanisms for reversibly activating or inactivating existing enzyme molecules, which enable swifter and potentially less wasteful adaptation. These reversible mechanisms are discussed in the following slides.

2.5.1 The phosphofructokinase reaction

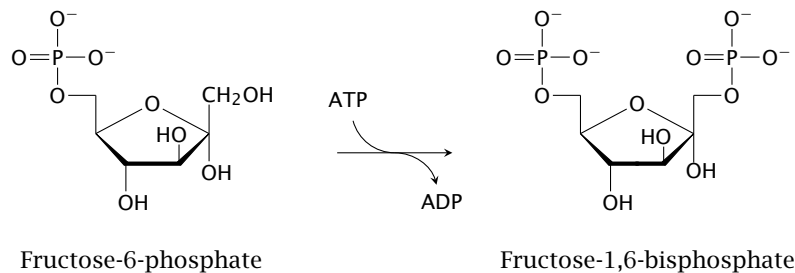

Notes: The enzyme phosphofructokinase transfers a phosphate group from ATP to fructose-6-phosphate, producing fructose-1,6-bisphosphate. This reaction occurs as an early step in the degradation of glucose. Since this pathway ultimately serves to regenerate ATP from ADP and phosphate, one might expect phosphofructokinase to be activated by ADP. However, it turns out that activation is mediated by AMP instead. The rationale for this preference is discussed in the next slide.

2.5.2 The adenylate kinase reaction equilibrates AMP, ADP and ATP

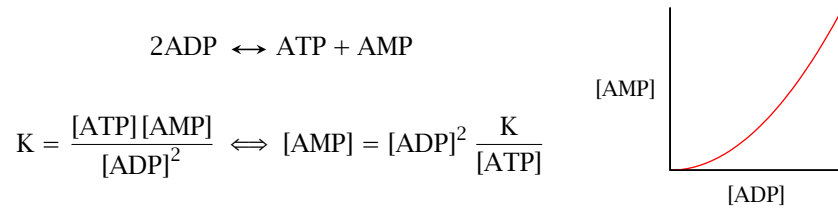

Notes: When ATP is consumed and ADP levels rise, some ATP can be regenerated by adenylate kinase, which turns two ADP molecules into one ATP and one AMP. According to the law of mass action, this also means that AMP levels rise quadratically with the level of ADP (assuming that changes to the level of ATP are small, which is usually the case). Its steeper rise makes AMP a better sensor of cellular energy demand than ADP itself, and it therefore makes sense that AMP, not ADP regulates the activity of phosphofructokinase.

 **2.5** Explain how the cellular levels of AMP, ADP and ATP are related to each other.

2.5.3 Allosteric regulation of phosphofructokinase by AMP

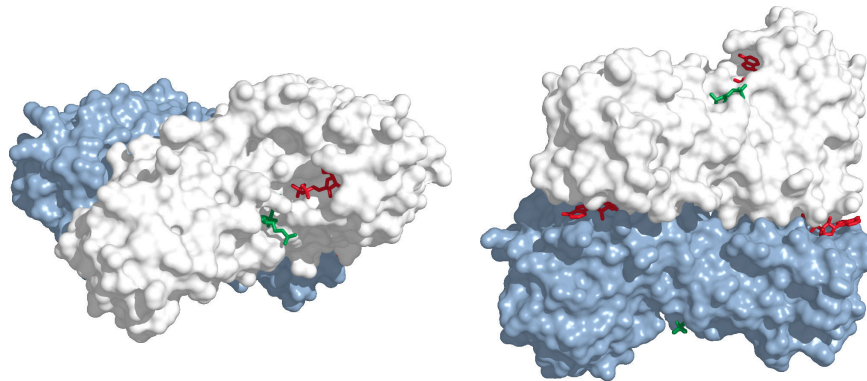

Notes: To accomplish the stimulation of phosphofructokinase, AMP interacts with the enzyme at an *allosteric* binding site, that is, a site that is distant and functionally distinct from the active site. In this structure of the dimeric enzyme (rendered from [1pfk.pdb](#)), two molecules of ADP are bound for each enzyme subunit. The left panel shows an ADP molecule (red) bound in one of the active sites, which also contains the other product of the reaction (fructose-1,6-bisphosphate, green). The side view in the right panel shows two more ADP molecules bound at the interface of the two enzyme subunits, within the allosteric binding sites that in the cell would bind AMP rather than ADP. The fourth ADP molecule in the second active site is hidden from view.

The adenine nucleotides bound at the two different sites assume entirely different roles. The ADP in the active site participates in the reaction. The AMP in the allosteric site does not; instead, its job is to change the conformation of the entire enzyme molecule. This conformational change will be transmitted through

the body of the protein to the active site and increase the efficiency of catalysis there.

Allosteric regulation of enzymes is exceedingly common; it is not limited to nucleotides or any other particular class of metabolites. Allosteric effectors can be either stimulatory, as is AMP in this example, or inhibitory. As an example of the latter, ATP is not only a cosubstrate but also an allosteric inhibitor of phosphofructokinase.

Considering that the main purpose of the degradative pathway downstream of phosphofructokinase is regeneration of ATP, it makes sense to reduce the substrate flow through this pathway when ATP levels are high. The allosteric effect of ATP on phosphofructokinase is an example of *feedback inhibition*, that is, the inhibition of an early step in a pathway by that pathway's main product. This is a very common principle in metabolic regulation.

2.5.4 How allosteric regulation works

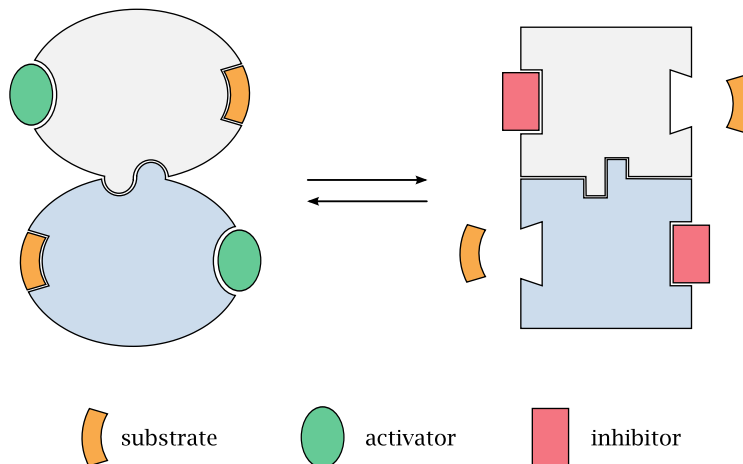

Notes: An allosterically regulated enzyme has two possible conformations that are in equilibrium with each other. Both the active site and the allosteric binding site change shape along with the molecule. An allosteric activator will bind selectively to the regulatory site in the shape that it assumes in the enzyme's active conformation; the binding energy will shift the equilibrium towards this conformation. Conversely, an inhibitor will selectively bind and stabilize the enzyme's inactive conformation.

As you can see from these considerations, activators and inhibitors may share the same regulatory site; with phosphofructokinase, this applies to ATP and AMP. Note, however, that human phosphofructokinase has an additional allosteric site that permits regulation by another effector (see slide [7.5.3](#)).

2.5.5 Enzyme regulation by protein phosphorylation

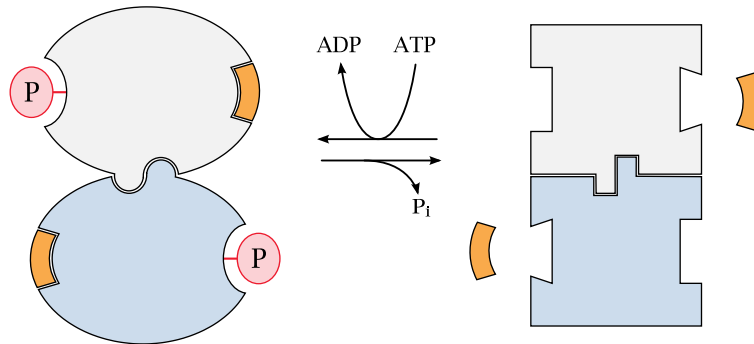

Notes: Another important means of regulating enzyme activity is through phosphorylation of the enzyme molecules. This is mediated by protein kinases, which transfer a phosphate group from ATP to specific amino acid side chains on the regulated enzymes.

When considering how protein phosphorylation works, it is best to think of the transferred phosphate group as an allosteric effector that happens to be covalently attached to the enzyme. Like proper allosteric regulators, the phosphate group imposes a conformational change that is transmitted to the active site through the body of the protein; and in both cases, it depends entirely on the enzyme in question whether it responds to the effector with an increase or a decrease in activity. For example, ATP allosterically inhibits phosphofructokinase, but it activates the functionally opposite enzyme fructose-1,6-bisphosphatase (see slide 7.5.3). Similarly, phosphorylation inhibits glycogen synthase but activates glycogen phosphorylase, which degrades glycogen (slide 8.4.1).

The major difference between allosteric regulation on the one hand and protein phosphorylation on the other is in the duration; an allosteric effector will dissociate as soon as its concentration drops, whereas phosphorylation will remain in effect until it is reversed by a specific protein phosphatase. Another, less obvious difference is that phosphorylation can apply to multiple sites in one protein. For example, in endothelial nitric oxide synthase (see slide 9.3.5), phosphorylation of alternate sites causes either activation or inhibition, respectively; this is managed by separate, site-specific protein kinases. In contrast, multiple and strictly alternate sites are not feasible with non-covalently binding allosteric effectors.



2.6 Enzymes may be regulated by allosteric effectors and through phosphorylation. Discuss the similarities and differences between both regulatory mechanisms.

2.5.6 Oligomeric enzymes behave cooperatively

Notes: While allosteric control is in principle feasible with both monomeric and oligomeric enzyme molecules, almost all allosteric enzymes are indeed oligomeric proteins. Phosphofructokinase is a dimer; this is not uncommon, but often the

number of subunits is considerably larger. Oligomeric enzymes usually respond *cooperatively* to effector binding, which means that all subunits change conformation simultaneously. This enables the enzymes to react more sensitively to small changes in effector concentration. Cooperative responses may be observed not only with allosteric effectors but also with substrates.

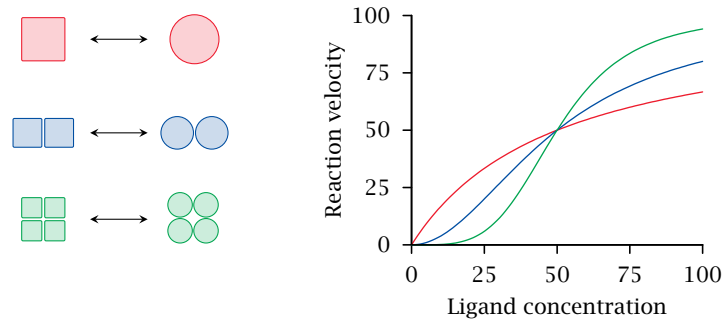

This slide illustrates theoretical dose-response curves for monomeric, dimeric and tetrameric enzymes. Each subunit is assumed to bind the ligand with the same affinity; the differences in curve shape arise from cooperativity alone. Note, however, that cooperativity may be partial, which means that oligomer subunits retain a degree of independence. Partial cooperativity results in experimental dose-response curves that are not as steep as theoretically possible.

2.5.7 Substrate cycles can amplify molecular regulation mechanisms

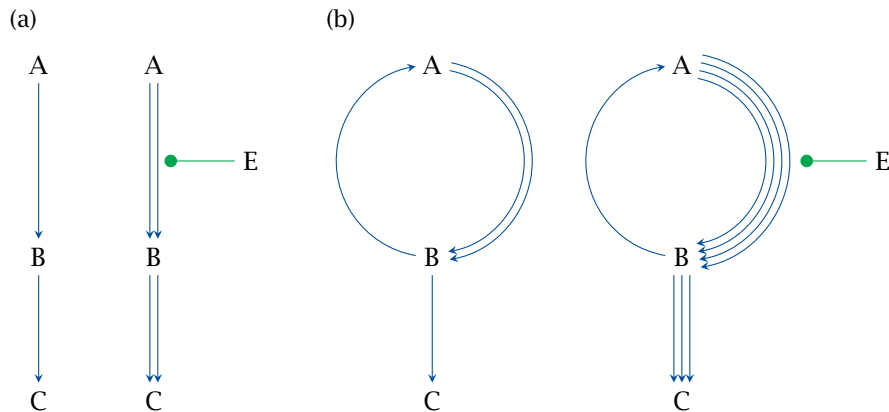

Notes: Cooperativity is one device for increasing the sensitivity of metabolic flux to regulation; substrate cycles are another. This is illustrated here for activation, but it applies similarly to inhibitory effectors as well. Let's consider a simple, hypothetical pathway $A \rightarrow B \rightarrow C$ (panel a). The rate is limited by the first reaction ($A \rightarrow B$), so that the basal throughput of both reactions is the same; we may assume that this flow rate equals 1. If we apply an effector E that doubles the rate of the forward reaction $A \rightarrow B$, the subsequent reaction $B \rightarrow C$ will be accelerated by the same factor, since we assumed the first reaction to be rate-limiting.

We can achieve the same basal throughput for $B \rightarrow C$ as in (a) using a substrate cycle between A and B, in which one enzyme converts A to B with a flow rate of 2, and a second enzyme converts B back to A with a rate of 1 (panel b). If we now add the same effector as in (a) and accordingly double the flow rate $A \rightarrow B$, we obtain a flow rate of 4 for $A \rightarrow B$. Diminished by the unchanged flow $B \rightarrow A$, the resulting net flow rate for $B \rightarrow C$ becomes 3. The substrate cycle therefore amplifies the increase in metabolic flux in response to the same regulatory effect of E. This regulatory mechanism could be made even more effective by subjecting the step $B \rightarrow C$ to inhibition by E; such a pattern is observed for example with the substrate cycle formed by phosphofructokinase and fructose-1,6-bisphosphatase (slide 7.5.3).

Substrate cycles occur in several places in metabolism; we will see some examples in sections 6.10 and 7.5. In order to crank such a cycle, some energy must be expended—for example, the forward reaction may hydrolyze ATP, while the reverse reaction does not regenerate it. This energy expenditure becomes the net effect of the cycle, and for this reason substrate cycles are also referred to as *futile cycles*. The energy is simply dissipated as heat, which to a degree may be useful, particularly in warm-blooded animals; however, the throughput of such cycles must always be kept in check in order to avoid excessive energy wastage.

2.5.8 Regulation of enzyme molecule abundance

- transcriptional induction
- accelerated mRNA degradation
- ubiquitin ligation, followed by proteolytic degradation

Notes: While all of the mechanisms discussed above reversibly modulate the activity of existing enzyme molecules, an enzyme's activity may also be varied by changing its abundance in the cell. Firstly, the transcription of the gene encoding the enzyme can be turned on or off. This mechanism is employed by many hormones, for example thyroid hormones or cortisol and other steroid hormones. Similarly, the stability of the messenger RNA encoding the enzyme can be up- or downregulated by RNA-binding proteins and other mechanisms [1], with the corresponding effects on the abundance of the enzyme molecules.

Enzyme molecules can also be tagged with a small protein named *ubiquitin*, which marks the protein for proteolytic degradation within the proteasomes. Hormones may affect the activity of an enzyme through more than one of these mechanisms. For example, insulin increases the activity of glycogen synthase by way of transcriptional induction, increasing mRNA stability, and inhibition of protein phosphorylation.

In the following chapters, we will discuss the details of regulation only with some selected enzymes. Nevertheless, please keep in mind that virtually all enzyme molecules are subject to one or more regulatory mechanisms. The importance of these molecular control mechanisms in the regulation of metabolism as a whole cannot be overstated.

2.6 Answers to practice questions

2.1: The catalytic triad is found in the active sites of esterases and peptidases. It comprises the side chains of three amino acid residues, namely, aspartate, histidine, and serine. In the catalytic mechanism, aspartate and histidine cooperate to deprotonate the hydroxyl group of serine, which thus becomes the nucleophile that cleaves the substrate's ester or amide bond through attack on its carbonyl group.

2.2: Most likely because someone on the Enzyme Commission had a sense of humor.

2.3: ΔG measures the difference in free energy between the substrate and the product of a reaction and thus determines its equilibrium. ΔG^* measures the difference in free energy between the substrate and the transition state of the reaction and determines its rate. An enzyme that catalyzes the reaction will lower ΔG^* but not affect ΔG ; it will increase the rate, but not change the equilibrium of the reaction.

2.4: The terminal phosphate of ATP is transferred to the side chain carboxyl group of glutamate. This produces a mixed anhydride, from which ionic phosphate is released after substitution by free ammonia.

2.5: The three metabolites are at equilibrium, which is mediated by adenylate kinase. This enzyme reversibly converts two molecules of ADP to ATP plus AMP. AMP rises more sharply than ADP when ATP levels decline.

2.6: Allosteric effectors bind non-covalently, whereas phosphorylation is a covalent modification. Like allosteric effectors, regulatory phosphate groups are typically bound at a location other than the active site, and both affect enzyme activity through conformational changes that are transmitted to the active site. In both cases, it depends on the enzyme molecule itself whether the regulatory effect consists in activation or inhibition.

Chapter 3

Glycolysis

3.1 Overview of glucose metabolism

Pathway	Function
glycolysis, citric acid cycle, respiratory chain	complete degradation of glucose for ATP production
hexose monophosphate shunt	degradation of glucose for regeneration of NADPH
glycogen synthesis and degradation	short-term glucose storage
gluconeogenesis	synthesis of glucose from amino acids, lactate, or acetone

Notes: Glucose is a key metabolite in human metabolism, and we will spend a good bit of time on the various pathways that are concerned with the utilization, storage, and regeneration of glucose. The first step in the degradation of glucose is glycolysis, which breaks down glucose to pyruvate. The main purpose of glycolysis is the generation of energy (ATP). A modest amount of ATP is produced in glycolysis directly, but much more ATP is formed downstream of glycolysis through the complete oxidation of pyruvate.

An alternative pathway for complete glucose breakdown is the hexose monophosphate shunt, which produces NADPH rather than ATP. Both ATP and NADPH are needed in every cell, and accordingly both glycolysis and the hexose monophosphate shunt are ubiquitous.

Glycogen is a polymeric storage form of glucose, not unlike starch, which is found in plants. Glycogen is most abundant in the liver and in striated muscle,¹

¹Striated muscle comprises skeletal muscle and heart muscle. The second major type of muscle tissue is smooth muscle, which occurs in blood vessels and internal organs and is under control by the autonomic nervous system.

although some is found in other tissues also. Glycogen is synthesized when glucose supply is high, and its degradation helps to maintain the blood glucose level when we are fasting. When glycogen is depleted, more glucose is synthesized from scratch in gluconeogenesis. This pathway's most important substrates are amino acids, which are obtained either from a protein-rich diet—for example, when we feast on meat exclusively—or, during starvation, from breakdown of cellular protein, mainly in skeletal muscle. Gluconeogenesis occurs in the liver and in the kidneys.

3.1.1 The place of glycolysis in glucose degradation

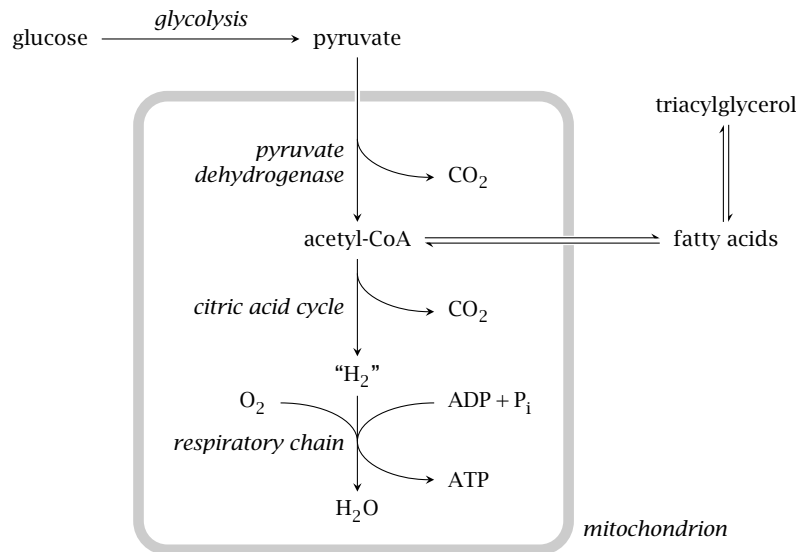

Notes: As noted above, glycolysis is only the first stage of glucose degradation. Under aerobic conditions, most of the pyruvate formed in glycolysis undergoes complete oxidative degradation to CO₂ and H₂O.

Pyruvate destined for complete degradation is transported to the mitochondria, where it is decarboxylated to acetyl-CoA by pyruvate dehydrogenase. Acetyl-CoA is completely degraded in the citric acid cycle (or tricarboxylic acid cycle; TCA cycle for short). The "H₂" that is produced here is not gaseous but bound to cosubstrates, as NADH + H⁺ and FADH₂, respectively. It is subsequently oxidized in the respiratory chain; it is in this final stage of glucose breakdown that most of the ATP is actually produced.

If glucose is available in excess of immediate needs and glycogen is already stocked up to capacity, it will still be broken down by glycolysis and pyruvate dehydrogenase to acetyl-CoA. However, acetyl-CoA will then not be oxidized, but it will instead be used for fatty acid synthesis; the fatty acids are converted to triacylglycerol. Fatty acid synthesis occurs in the cytosol of cells in the liver and fat tissue.

We will now consider all these pathways in their turn, starting in this chapter with glycolysis.



3.1 Name the pathways involved in glucose utilization and summarize their functions.

3.1.2 Alternate structures of D-glucose

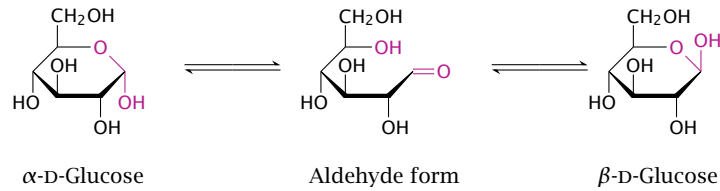

Notes: Glucose occurs in α and β ring forms that are anomeric at the C1 carbon (highlighted). In the presence of water, one form can reversibly change into the other via an open-chain aldehyde form. Polymers of glucose contain either the α or the β ring form. Within most of these polymers, the C1 hydroxyl groups participate in glycosidic bonds, which prevents ring opening, and therefore the spontaneous transitions between the anomeric forms cannot occur. Starch and glycogen consist of α -D-glucose and yield it during degradation, and this form is also the first substrate in glycolysis.

3.2 Reactions in glycolysis

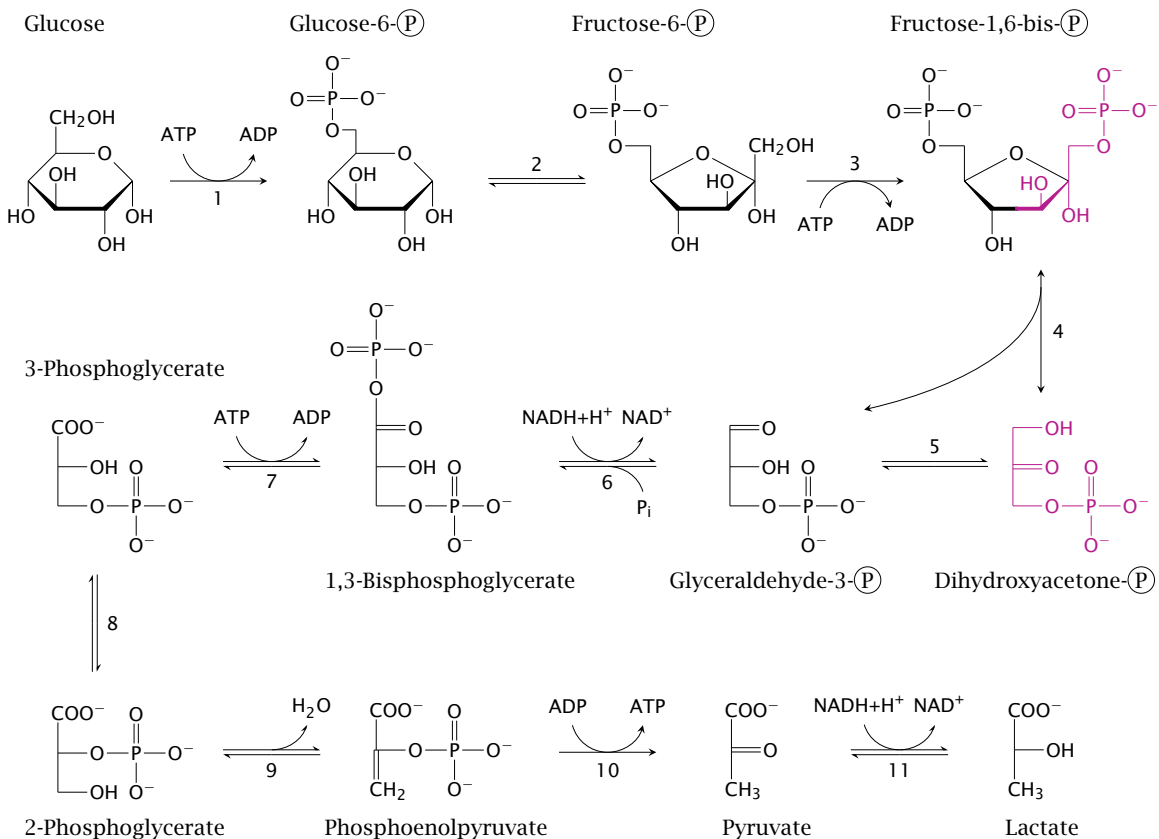

Notes: Glycolysis involves 10 enzymatic reactions, as follows:

1. The phosphorylation of glucose at position 6 by hexokinase,
2. the conversion of glucose-6-phosphate to fructose-6-phosphate by phosphohexose isomerase,
3. the phosphorylation of fructose-6-phosphate to the 1,6-bisphosphate by phosphofructokinase,
4. the cleavage of fructose-1,6-bisphosphate by aldolase. This yields two different products, dihydroxyacetone phosphate and glyceraldehyde-3-phosphate,²
5. the isomerization of dihydroxyacetone phosphate to a second molecule of glyceraldehyde-3-phosphate by triose phosphate isomerase,
6. the dehydrogenation and concomitant phosphorylation of glyceraldehyde-3-phosphate to 1,3-bis-phosphoglycerate by glyceraldehyde-3-phosphate dehydrogenase,
7. the transfer of the 1-phosphate group from 1,3-bis-phosphoglycerate to ADP by phosphoglycerate kinase, which yields ATP and 3-phosphoglycerate,
8. the isomerization of 3-phosphoglycerate to 2-phosphoglycerate by phosphoglycerate mutase,
9. the dehydration of 2-phosphoglycerate to phosphoenolpyruvate by enolase, and finally
10. the transfer of the phosphate group from phosphoenolpyruvate to ADP by pyruvate kinase, to yield a second molecule of ATP.

Most of the pyruvate produced in step 10 undergoes oxidative degradation in the mitochondria. The 11th reaction, catalyzed by lactate dehydrogenase, mostly occurs under anaerobic conditions (see section 3.4), or in those cells that have no mitochondria and therefore lack the ability to oxidatively degrade pyruvate altogether. The latter applies to red blood cells and thrombocytes. Lymphocytes, which do have mitochondria, apparently rely largely on anaerobic glycolysis as well.

Most, but not all reactions in glycolysis are reversible; this is indicated in the slide by double and single arrows, respectively. Because it contains several irreversible reactions, the pathway as a whole is also irreversible. However, as discussed in chapter 7, alternate routes exist that bypass the irreversible reactions and allow glucose to be synthesized from pyruvate.



3.2 Name the metabolites and enzymes in glycolysis.

3.3 Mechanisms of enzyme catalysis in glycolysis

Metabolic reactions are catalyzed by enzymes. Enzymes are not magicians but sophisticated catalysts, and their chemical mechanisms are often understood quite well, at least in principle. We will now look at the catalytic mechanisms of several enzymes from glycolysis. Some of these mechanisms will recur in similar form in enzymes from other pathways.

²Aldolase is sometimes referred to as aldolase A, in order to distinguish it from aldolase B, which occurs in fructose degradation (see slide 4.2.1)

Our first example is hexokinase, which carries out the first reaction in the glycolytic pathway. The kind of reaction that it carries out—the transfer of the terminal phosphate group from ATP onto a hydroxyl group on the substrate—is very common in biochemistry, and we will see more examples in these notes. The mechanism of phosphorylation is always the same, so it suffices to discuss it once.

3.3.1 The phosphate groups in ATP are shielded from nucleophilic attack

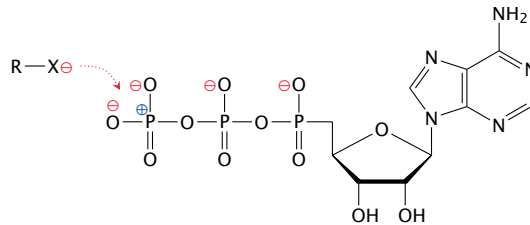

Notes: Most reactions that involve the transfer of a phosphate group from ATP to something else are exergonic, that is, they are energetically favorable. For example, the hydrolysis of ATP—that is, the transfer of the phosphate group to water—has a free energy of -35 J/k mol . It is interesting to note then that ATP is nevertheless quite stable in solution, which means that there must be a high activation energy barrier that resists hydrolysis of the phosphate anhydride bond.

This energy barrier is due to the negative charges at the perimeter of the triphosphate group that shield the phosphorus atoms in the center from nucleophiles which are also negatively charged. Accordingly, to lower this barrier, kinases provide compensating positive charges within their active sites that engage the negative charges on the ATP molecule and thereby clear the way for nucleophilic attack on the phosphorus.

3.3.2 The catalytic mechanism of hexokinase

Notes: In hexokinase, the negative charges of the phosphate groups are shielded by magnesium ions and by positively charged amino acid side chains in the active site. This facilitates nucleophilic attack by and phosphate group transfer to the substrate.

The charge shielding mechanism solves one problem, but another one remains, namely, how to limit the reaction to the right nucleophile. After all, the most abundant nucleophile in the cell is water, which should make hydrolysis the most likely outcome of ATP activation. This problem is addressed in the next slide.

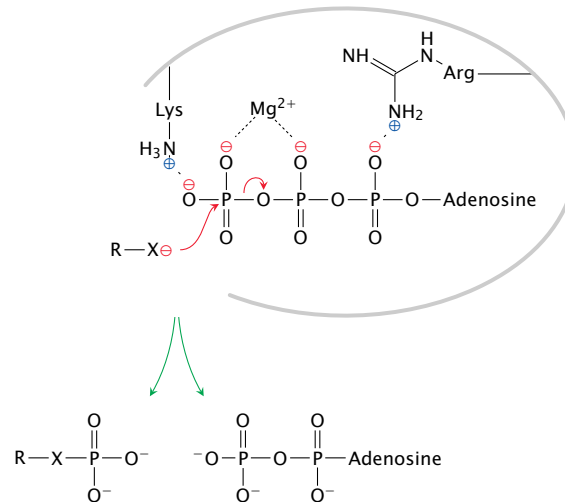

3.3.3 Hexokinase envelopes its substrates to prevent ATP hydrolysis

Notes: After binding of its substrate glucose (yellow and red) and its cosubstrate ATP (not shown), hexokinase adopts a closed conformation, in which substrate and cosubstrate are buried within the enzyme, and water is excluded from the active site and from the reaction (left). The magnified view on the right shows the C6 oxygen of glucose peeking out of the enzyme's active site; ATP would occupy the cavity above. Rendered from [3b8a.pdb](#).

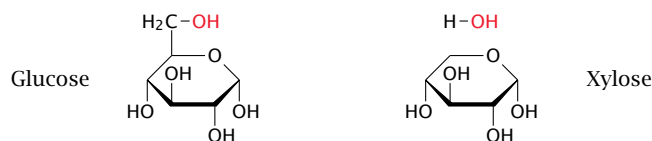
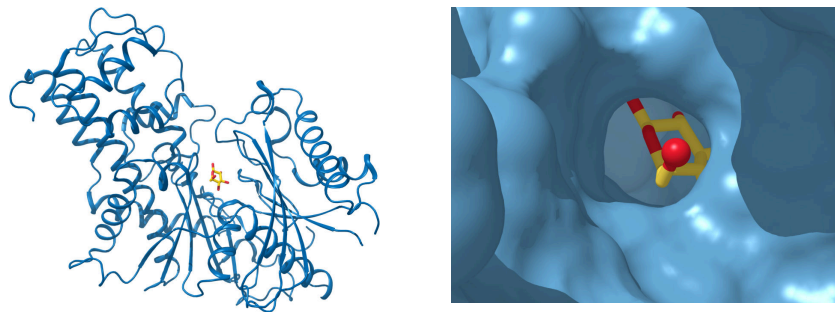

If the enzyme is given xylose instead of glucose, one water molecule can squeeze into the active site along with the sugar. This water assumes the place of the C6 hydroxymethyl group of glucose, and it will be activated by hexokinase to react with ATP, which will result in ATP hydrolysis.



3.3 Explain the catalytic mechanism of hexokinase.

3.3.4 Phosphohexose isomerase performs acid-base catalysis

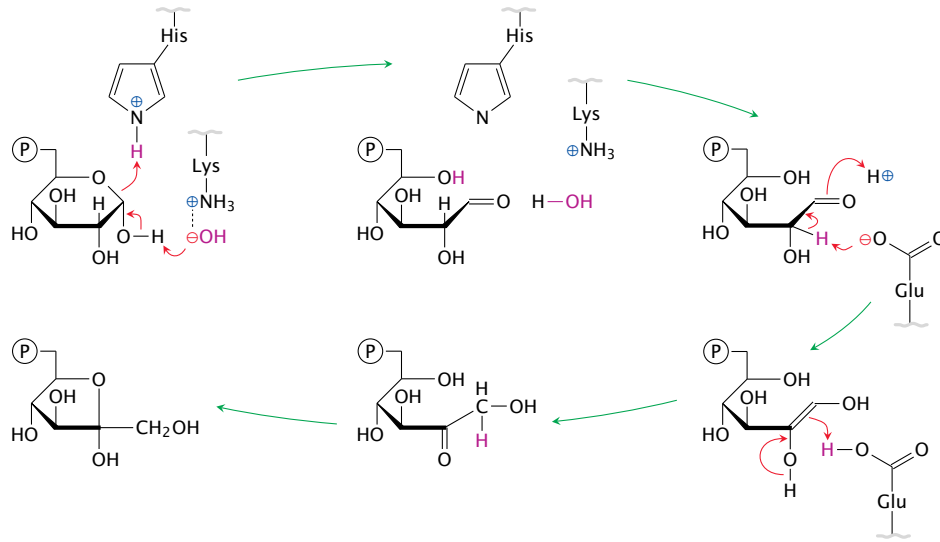

Notes: Phosphohexose isomerase provides an excellent example of acid-base catalysis, which involves the reversible protonation and deprotonation of the substrate. The substrate's hemiacetal bond is opened by the concerted action of a protonated histidine and of a hydroxide ion, which at the outset is bound to a lysine residue. Then, a glutamate residue abstracts a proton from C2 and donates it back to C1, which causes the C=O double bond to migrate from C1 to C2.

Not shown in the picture are several auxiliary charged residues in the active site, which form ion pairs with charges that develop transiently on the substrate, and thereby stabilize the transition state. Closure of the hemiacetal bond in fructose-6-phosphate, which concludes the reaction, is analogous to the initial ring opening and involves the same catalytic amino acid residues [2].

3.3.5 Glyceraldehyde-3-phosphate dehydrogenase carries out covalent catalysis

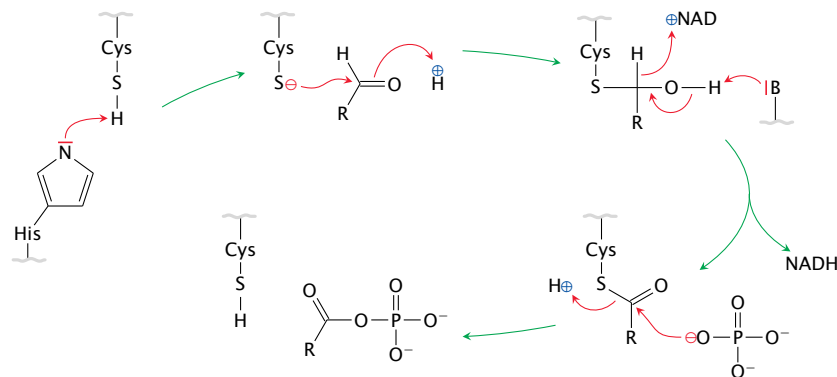

Notes: Glyceraldehyde-3-phosphate dehydrogenase provides a straightforward example of covalent catalysis. This reaction mechanism is very common in dehydro-

genation reactions, for example in the citric acid cycle and in the β -oxidation of fatty acids. The reaction goes through the following steps:

1. A cysteine in the enzyme's active site is deprotonated by an auxiliary histidine to a thiolate anion ($-S^-$).
2. Glyceraldehyde-3-phosphate (shown as $R-(=O)-H$) binds to the active site, and the thiolate performs a nucleophilic attack on its aldehyde carbon. This yields a tetrahedral intermediate state, in which the substrate becomes bound covalently to the enzyme—hence the term “covalent catalysis”.
3. The covalent intermediate gives up two electrons and two protons to NAD^+ and the enzyme, which yields NADH and converts the substrate to a thioester. NADH leaves.
4. The thioester is cleaved by a phosphate ion, again through nucleophilic attack. The product (1,3-bisphosphoglycerate) leaves, and the enzyme is restored to its original state.

The redox cosubstrate used by glyceraldehyde-3-phosphate dehydrogenase, nicotinamide adenine dinucleotide (NAD^+), also accepts most of the hydrogen that accrues in the degradative pathways downstream of glycolysis. Its structure and the details of its reduction by hydrogen are shown in slide 3.3.6.



3.4 Summarize the catalytic mechanisms of phosphohexose isomerase and of glyceraldehyde-3-phosphate dehydrogenase.

3.3.6 Structure and redox chemistry of NAD^+ and $NADP^+$

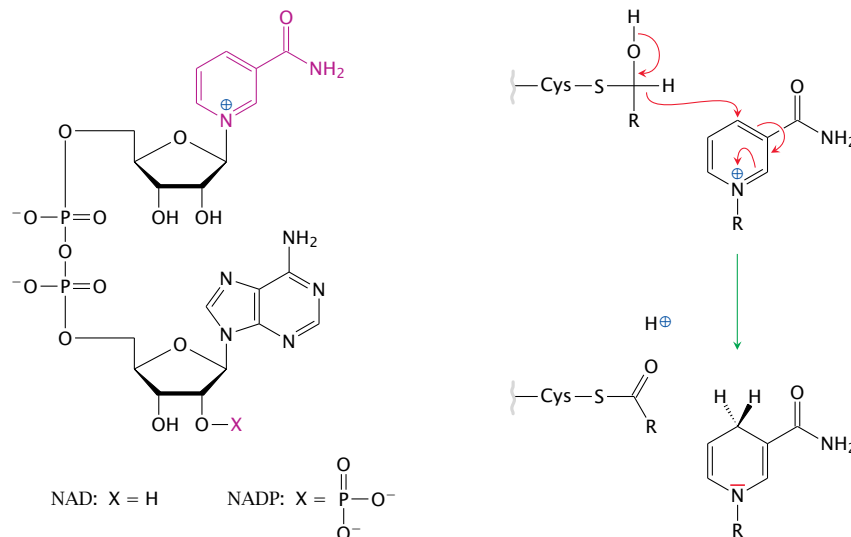

Notes: The panel on the left shows the structure of NAD^+ and $NADP^+$; the redox-active nicotinamide moiety is highlighted. The panel on the right shows the reduction of this moiety by glyceraldehyde-3-dehydrogenase. The electrons and the hydrogen are transferred from the substrate to the C_4 of the nicotinamide. The electrons then redistribute within the ring.

As you can see, NAD^+ and NADP^+ differ solely by the absence or presence of a phosphate group at the lower ribose ring, which has absolutely nothing to do with the actual redox chemistry. Why, then, is it there at all? It simply serves as a tag that allows NAD^+ and NADP^+ to interact with separate sets of enzymes. The significance of this duality is discussed in a later chapter (see slide 9.3.1).

3.3.7 Pyruvate Kinase

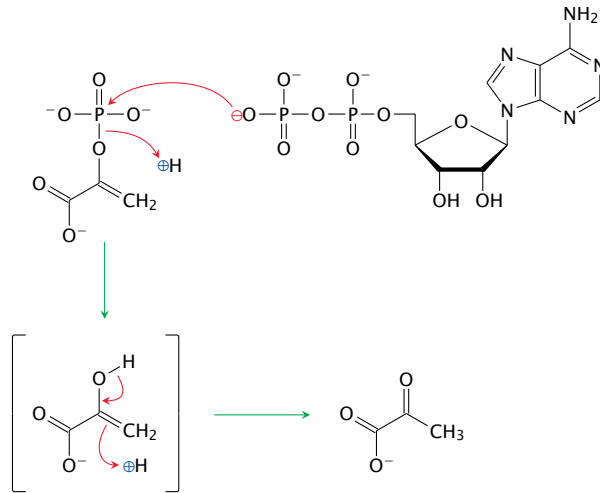

Notes: The mechanism of pyruvate kinase is similar to that of hexokinase—except that the reaction proceeds the other way, producing ATP rather than consuming it. Yet, both reactions are irreversible. How can this be?

In the hexokinase reaction, the terminal phosphate of ATP is converted from an anhydride to a phosphoester, which is inherently lower in energy; this makes the reaction exergonic and irreversible. The same also applies to phosphofructokinase and to most other phosphorylation reactions. However, the pyruvate kinase is a special case. Its intermediate product, which occurs immediately after transfer of the phosphate group from phosphoenolpyruvate to ADP, is enolpyruvate. Removal of the phosphate group allows the enol group to rearrange itself into a keto group. This second step of the reaction is sufficiently exergonic to offset the energetic cost of converting the phosphoester to the anhydride, and it thus pushes the overall equilibrium of the reaction towards ATP formation.



3.5 Explain why the reactions catalyzed by hexokinase and pyruvate kinase are both irreversible, but proceed in opposite directions.

3.3.8 Energy-rich functional groups in substrates of glycolysis

- the enolphosphate in PEP
- the carboxyphosphate in 1,3-bisphosphoglycerate
- the thioester in the active site of glyceraldehyde-3-dehydrogenase

Notes: As you know, the most abundant and important energy-rich metabolite in the cell is ATP. Within this molecule, the energy is stored in the energy-rich phosphate anhydride bonds. Cleavage of these bonds is exergonic, and the energy released by cleavage drives the various reactions and processes powered by ATP. Conversely, in creating ATP from ADP, we require energy to form a new phosphate anhydride bond. We just saw how this energy is derived from phosphoenolpyruvate, and we thus may say that the enolphosphate group is another energy-rich group.

The first ATP in glycolysis is formed by cleavage of the carboxyphosphate mixed anhydride in 1,3-bisphosphoglycerate, and we may thus infer that such mixed anhydrides are energy-rich groups, too. The same functional group also occurs in acetylphosphate and in succinylphosphate, and both of these are capable as well to drive the formation of phosphate anhydride bonds in ATP or GTP.

In slide 3.3.5, we saw that the carboxyphosphate was formed from ionic phosphate and a thioester bond. Since the free phosphate ion is low in energy, it follows that the energy that went into the mixed anhydride came from the thioester. This means that thioesters are energy-rich groups, too.

3.4 Glycolysis under aerobic and anaerobic conditions

As we will see in subsequent chapters, the complete oxidative (aerobic) degradation of each glucose molecule yields approximately 30 molecules of ATP. How much of this accrues in glycolysis?

The initial phosphorylation reactions (steps 1 and 3 in slide 3.2) expend two molecules of ATP. One molecule of ATP each is obtained in steps 7 and 10. Since all of the steps from 6 to 11 occur twice per molecule of glucose, the net balance is a gain of two moles of ATP per mole of glucose—a very modest contribution to the final tally. Still, glycolysis is a viable source of ATP, and it is the major one that operates in our tissues under *anaerobic* conditions, that is, while oxygen is in short supply. This concerns mostly skeletal muscle during maximal exercise, such as a 100 meter dash. As noted above, erythrocytes and some other cell types rely on anaerobic glycolysis even under aerobic conditions.

3.4.1 Regeneration of cytosolic NAD^+ under aerobic conditions

Notes: The glyceraldehyde-3-phosphate dehydrogenase reaction (step 6 in slide 3.2) reduces one equivalent of NAD^+ to NADH. The concentration of NAD^+ in the cytosol is not high, and it must therefore be regenerated from NADH in order for glycolysis to continue. Under aerobic conditions, the hydrogen is transferred from NADH to one of several carriers that deliver it to the respiratory chain in the mitochondria, and ultimately to oxygen. These shuttle mechanisms are discussed in detail in section 6.9. Under anaerobic conditions, this is impossible; therefore, other means for hydrogen disposal are required.

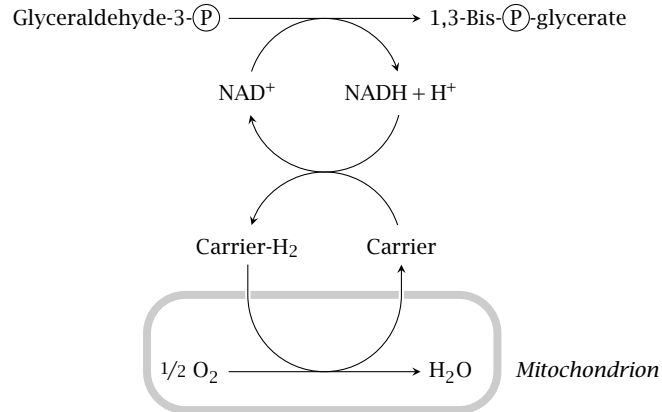

3.4.2 Under anaerobic conditions, NAD⁺ is regenerated by lactate dehydrogenase

Notes: In human metabolism, pyruvate serves as a makeshift hydrogen acceptor under anaerobic conditions; it is reduced to lactate by lactate dehydrogenase (step 11 in slide 3.2). The lactate is released into the bloodstream, where it accumulates; it is removed and recycled after restoration of oxygen supply. The muscle pain caused by lactate accumulation forces us to discontinue anaerobic exercise after a short while.³

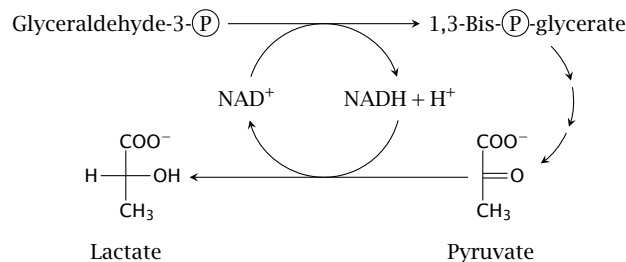

3.4.3 Ethanolic fermentation in yeast serves a dual purpose

Notes: Anaerobic glycolysis also occurs in many microbes, which also face the need to reoxidize NADH. Without the option of reverting to oxidative metabolism within a short time span, they must also deal with the continued accumulation of acid. The yeast *Saccharomyces cerevisiae* solves this problem through ethanolic fermentation: The acid is converted to a neutral and considerably less toxic compound (ethanol) via decarboxylation. The CO₂ developed in this reaction makes

³Measurement of the blood lactate concentration is performed in sports medicine to gauge the capacity of a trained athlete to sustain aerobic rather than anaerobic metabolism during prolonged exertion. The anatomical correlate of endurance is not so much the quantity of muscle tissue but the extent of its vascularization, that is, the abundance of capillaries in the tissue. A high density of capillaries ensures good oxygen supply.

bread dough rise up, whereas the ethanol does the same to government tax revenue.⁴

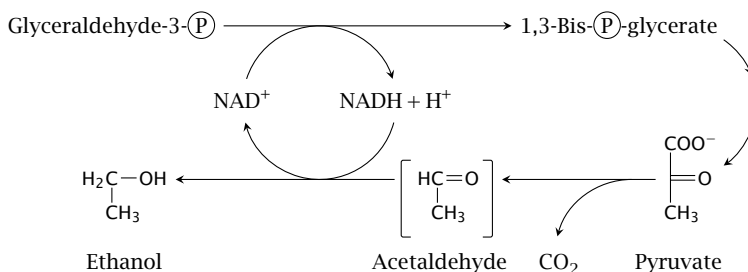

3.6 Explain how the NADH that accumulates in the glyceraldehyde-3-dehydrogenase reaction is oxidized under anaerobic conditions in humans and in baker's yeast.

3.5 Transport and utilization of glucose in the liver and in other organs

As was noted in slide 1.6.13, uptake of glucose from the blood occurs by facilitated diffusion and is mediated by GLUT transporters. These occur in several sub-types whose properties are tuned to the physiological roles of different organs.

3.5.1 Kinetics of glucose transport by facilitated diffusion

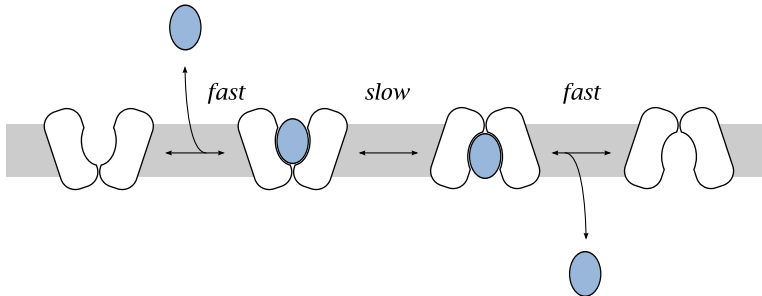

Notes: A typical carrier for passive substrate transport alternates between two conformations that are open to either side of the membrane. On both sides of the membrane, the substrate reversibly binds to the carrier protein; binding and dissociation are governed by mass action kinetics. Transport occurs when the protein changes from the outward-facing to the inward-facing conformation, or vice versa, while a substrate molecule is bound to it.

The sequence of events in passive transport resembles the pattern of Michaelis-Menten enzyme kinetics—in both cases, a solute binds reversibly to a protein, which then performs some state-altering action on it. Accordingly, the velocity of

⁴The English name of this organism is baker's yeast, but the literal translation would be "sugar fungus of the beer".

transport by facilitated diffusion follows the familiar Michaelis-Menten law:

$$V_{\text{transport}} = V_{\text{max}} \frac{[S]}{K_M + [S]} \quad (3.1)$$

where K_M is the Michaelis constant, $[S]$ is the substrate concentration, $V_{\text{transport}}$ is the rate of transport, and V_{max} is the maximum rate of transport. This rate is reached at high substrate concentrations, that is, when $[S] \gg K_M$.

V_{max} is proportional to the number of carrier molecules. In many tissues, the number of glucose transporters varies depending on insulin levels. In this way, insulin controls the rate of glucose uptake into cells in these tissues (see slide 13.2.16).

3.5.2 GLUT transporters in different tissues vary in their affinity for glucose

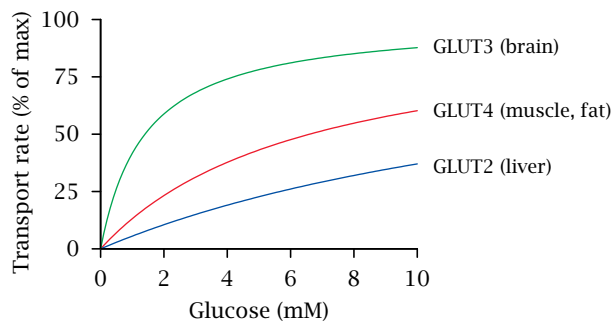

Notes: At lower substrate concentrations, the rate of transport becomes dependent on K_M , which is inversely related to the affinity of the transporter for the substrate. From equation 3.1, it can be seen that $V_{\text{transport}}$ will be equal to $1/2V_{\text{max}}$ when the glucose concentration equals K_M ; therefore, the smaller K_M , the more effective the uptake of glucose will be at low concentrations.

The smallest K_M —or in other words, the highest glucose affinity—occurs with the GLUT3 transporter subtype, which is found in the brain. Given that normal plasma glucose levels are between 4 and 7 mM, the brain will extract glucose efficiently at both high and low glucose levels. In organs with GLUT subtypes of lower affinity, the rate of uptake drops more significantly as glucose becomes depleted. The decrease in transport efficiency is most pronounced with the GLUT2 transporter, which occurs in the liver.

3.5.3 Reaction velocities of hexokinase and glucokinase

Notes: Organ-specific variation of glucose affinity is also observed at the stage of glucose phosphorylation. The liver has a special enzyme called glucokinase, which

performs the same reaction as does hexokinase but differs from the latter by a higher K_M value.⁵

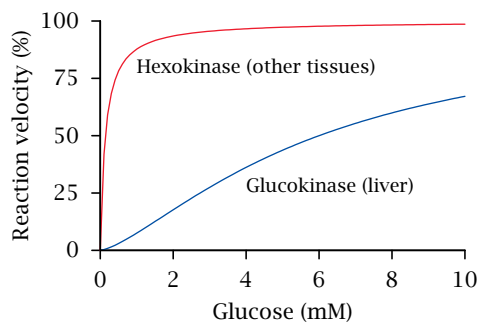

Accordingly, in the liver, phosphorylation will proceed more slowly when the level of blood glucose is low, and most of the glucose will be allowed to pass through the liver and make its way into the general circulation. In contrast, at high concentration, the liver will extract a greater share of the available glucose and convert it to glycogen or fatty acids. The kinetic properties of both glucose transport and phosphorylation therefore support the regulatory function of the liver in blood glucose metabolism.

At this point, we must note that the intrinsic kinetic properties of transporter and enzyme molecules are but one piece in the puzzle of glucose regulation. Insulin and several other hormones control the expression, distribution and activity of transporters and enzymes. Hormonal regulation is essential for proper coordination of glucose utilization, as is evident from its severe disturbances in diabetes mellitus and other endocrine diseases (see chapters 13 and 14).

The graphs in this slide and the previous one were plotted using parameters tabulated in references [4, 5, 6].



3.7 Explain how glucose uptake and utilization is prioritized between different tissues.

3.6 Answers to practice questions

3.1: See table in slide 3.1.

3.2: See the list in section 3.2.

3.3: Within the active site of hexokinase, the negative charges on the ATP molecule are shielded by magnesium and cationic amino acid residues, which facilitates nucleophilic attack by the hydroxyl group of glucose on the terminal phosphate of ATP. Hydrolysis of the activated ATP is prevented by exclusion of water from the active site.

3.4: Phosphohexose isomerase uses acid-base catalysis to open the pyranose ring of glucose-6-phosphate, then shift the carbonyl group from the first to the second carbon to produce fructose-6-phosphate, and finally close the furanose ring of the product. Glycerol-

⁵Glucokinase also binds glucose cooperatively, as is evident from the slightly sigmoidal shape of the graph. Interestingly, glucokinase is a monomer; apart from the active site, it also has a regulatory, allosteric glucose binding site [3].

More detailed analysis shows that there are more than two variants of glucose-6-kinase activity, and that organs may express more than one variant.

dehydro-3-phosphate dehydrogenase uses covalent catalysis to transfer hydrogen from its substrate to NAD^+ and then phosphorylate the remainder of the substrate to 1,3-bis-phosphoglycerate.

3.5: Like most other kinases, hexokinase catalyzes an exergonic phosphate transfer from ATP to its substrate. Pyruvate kinase, in contrast, is able to transfer phosphate in the opposite direction because this enables the product to undergo a strongly exergonic tautomerization from its enol to the keto form.

3.6: Humans reoxidize NADH by reducing pyruvate to lactate. Baker's yeast first decarboxylates pyruvate to acetaldehyde, which it then reduces to ethanol. NADH is reoxidized in the second reaction.

3.7: Organs with high priority, in particular the brain, have GLUT transporters and hexokinase isozymes with high affinity, which will work near maximum speed at both low and high concentrations. In contrast, organs with low priority, particularly the liver, express transporters and hexokinase isozymes (glucokinase) that have relatively high K_M values and therefore lose activity at low glucose concentrations. Glucose utilization is also affected by insulin, which is necessary for glucose uptake in many tissues (this applies in particular to muscle and fat tissue, see slide [13.2.15](#)).

Chapter 4

Catabolism of sugars other than glucose

4.1 Dietary sugars other than glucose

Trivial name	Composition	Source
lactose (milk sugar)	disaccharide of glucose and galactose	milk
sucrose	disaccharide of glucose and fructose	sugar cane, sugar beet, other fruits
fructose	monosaccharide	various fruits
sorbitol	sugar alcohol	fruits; semisynthetic
ribose, deoxyribose	monosaccharides	nucleic acids

Notes: Starch is the most abundant carbohydrate in our diet, which makes glucose the most important dietary monosaccharide. However, our diet contains several other sugars in significant amounts. The guiding motif in the metabolism of these sugars is economy: instead of completely separate degradative pathways, there are short adapter pathways which merge into the main pathway of carbohydrate degradation, that is, glycolysis.

Lactose and sucrose are disaccharides. Degradation of both sugars begins with hydrolytic cleavage, which releases glucose and galactose or glucose and fructose, respectively. Fructose is also found in the diet as a monosaccharide. We already know how glucose is degraded, so we here only need to concern ourselves with the remaining monosaccharides. The degradation of sorbitol will be discussed as well, whereas ribose and deoxyribose will be covered in later chapters.

 4.1 Name the major dietary carbohydrates other than starch/glucose.

4.2 Degradation of fructose and sucrose

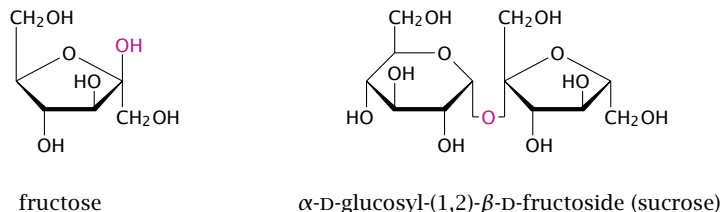

Notes: Sucrose is produced from sugar cane and sugar beet, which contain it in high concentrations (15–20%). In a typical Western diet, it may amount to as much as 20% of the total carbohydrate intake. Sucrose consists of glucose and fructose joined by a β -glycosidic bond between the carbon 1 of glucose and carbon 2 of fructose.

The hydrolytic cleavage of sucrose, like that of of maltose, occurs at the surface of the intestinal epithelial cells. The enzyme responsible is β -fructosidase, also named sucrase. Both sugars are then taken up by specific transport: Glucose by the SGLT1 transporter, and fructose by the GLUT5 transporter, which is named after glucose but actually transports fructose more effectively than glucose.

4.2.1 The fructolysis pathway

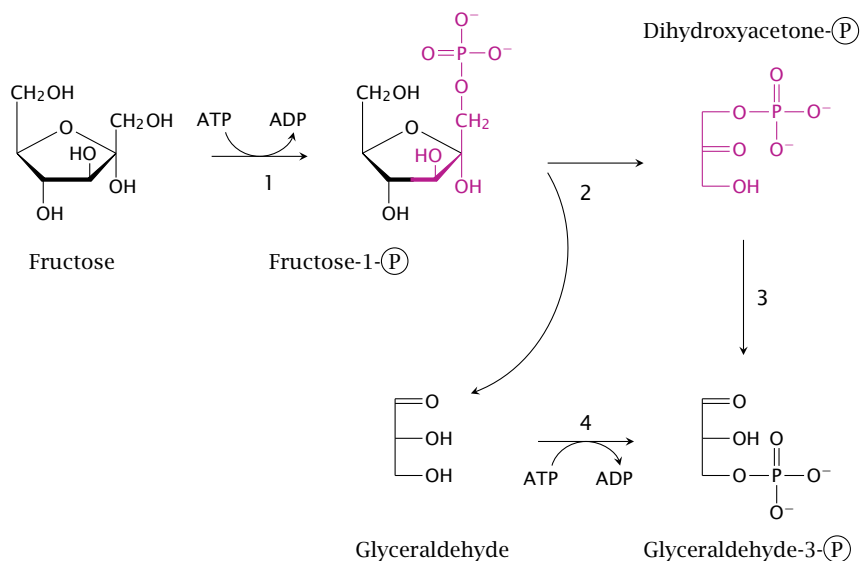

Notes: Fructose degradation, also called *fructolysis*, runs mostly in the liver. In the first step, fructose is phosphorylated by fructokinase (1), which uses ATP as a cosubstrate. This yields fructose-1-phosphate. The latter is then cleaved by aldolase B (2). The products of this reaction are dihydroxyacetone phosphate, which is already a metabolite in glycolysis, and glyceraldehyde, which can enter glycolysis after phosphorylation by glyceraldehyde kinase (4).

Glyceraldehyde can alternately be utilized by conversion to glycerol and then to glycerol-1-phosphate. The latter is a substrate in the synthesis of triacylglycerol, that is, fat. Fructose and sucrose appear to promote obesity more strongly than equivalent amounts of starch or glucose, and it has been suggested that its utilization via glycerol-1-phosphate, with subsequent triacylglycerol synthesis, may be among the reasons.

4.2.2 Fructose intolerance

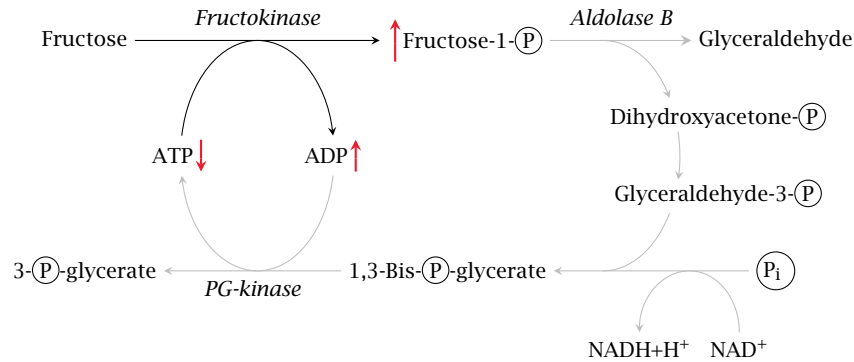

Notes: Fructose intolerance is a hereditary disease caused by a homozygous defect in the aldolase B gene. In this condition, fructose is still phosphorylated by fructokinase. The resulting fructose-1-phosphate, however, cannot be processed further, and therefore the phosphate tied up in it cannot be reclaimed. Since phosphate is required for the regeneration of ATP from ADP, this means that ATP will be lacking, too, which will sooner or later damage or even destroy the cell. Accordingly, the disease is characterized by potentially severe liver failure.

Fructose, alone or in combination with glucose, has been used in the past in the intravenous nutrition of intensive care patients; the perceived advantage of this treatment was the insulin-independent utilization of fructose. However, large intravenous dosages of fructose can significantly deplete liver ATP [7]; apparently, under heavy load, aldolase B may be unable to keep up with fructose kinase. Fructose is no longer a major component of intravenous nutrition schemes.

A defect in the gene encoding fructokinase leads to a condition named fructosemia or fructosuria. As these names suggest, fructose levels are increased both in the blood¹ and the urine. Since fructose is not phosphorylated, no phosphate depletion occurs, and the liver cells do not incur any damage. The disease is therefore quite benign.



4.2 Explain how fructose is degraded, and the causation of fructose intolerance and of fructosemia.

¹*Haima* is the Greek word for blood; hematology is the medical discipline that deals with diseases of the blood.

4.3 Lactose and galactose

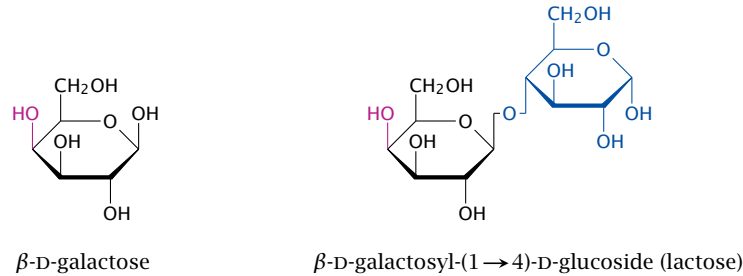

Notes: Lactose, a disaccharide of glucose and galactose, is the major carbohydrate contained in milk. Like maltose and sucrose, it is cleaved at the brush border of the small intestine, and the monosaccharide fragments are absorbed and passed along to the liver. The enzyme that accomplishes the cleavage is lactase or, more precisely, β -galactosidase.

4.3.1 The Leloir pathway for galactose utilization

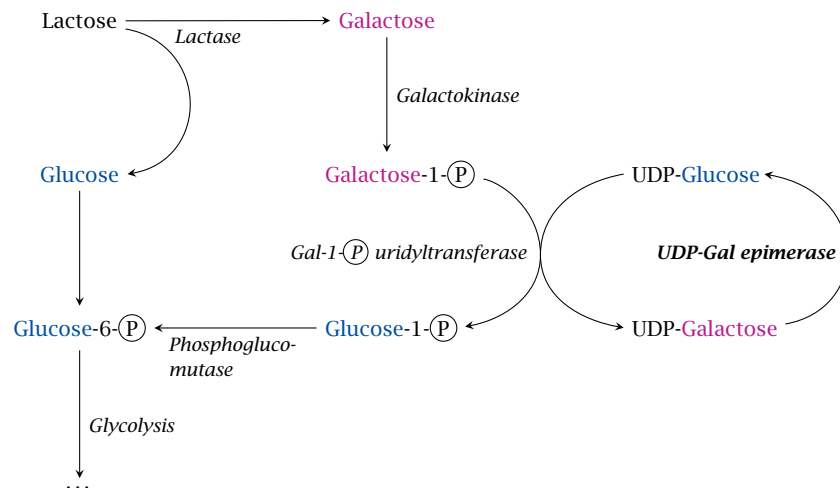

Notes: Galactose is utilized by conversion to glucose; this happens to a large extent in the liver, but the pathway is active in other tissues as well. The sugar is first phosphorylated by galactokinase. The resulting galactose-1-phosphate undergoes an exchange reaction with UDP-glucose, which is catalyzed by galactose-1-phosphate uridyltransferase and releases glucose-1-phosphate and UDP-galactose. Glucose-1-phosphate can be converted by phosphoglucomutase to glucose-6-phosphate, which is the first intermediate in glycolysis. UDP-galactose is converted to UDP-glucose by UDP-galactose epimerase.

In this pathway, UDP-glucose and UDP-galactose fulfill catalytic roles but are not subject to any net turnover, much like the intermediates in the citric acid cycle. It might therefore be said that they form a tiny metabolic cycle between the two of them. Also note that, save for the final epimerase reaction, the pathway is really just smoke and mirrors—performing the epimerization on galactose directly

would accomplish the same net effect, without being chemically more difficult in any way.²



4.3 Summarize the Leloir pathway of galactose degradation.

4.3.2 Mechanism of UDP-galactose epimerase

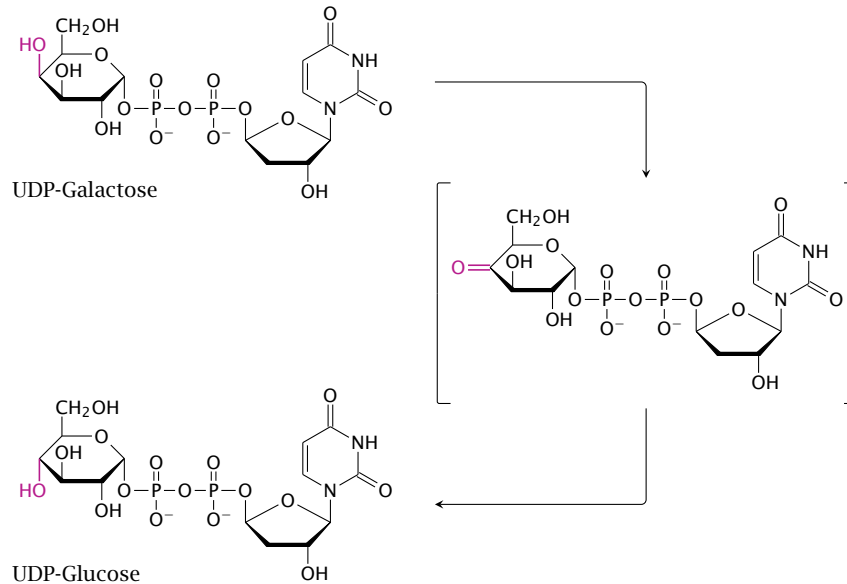

Notes: One unusual feature of UDP-galactose epimerase is its use of NAD^+ as a coenzyme, rather than as a cosubstrate—that is, NAD^+ undergoes no net reduction or oxidation in this case. Nevertheless, it functions here much in the same way as it does in other enzyme reactions. The 4'-hydroxyl group of the sugar is transiently dehydrogenated to a keto group, and in this step NAD^+ accepts the abstracted hydrogen. The substrate is then rotated within the active site before the H_2 is transferred back to it, which causes the 4'-OH group to now point the other way.

4.3.3 Lactose intolerance

Notes: A deficiency of the lactase enzyme in the small intestine gives rise to *lactose intolerance*, which is found frequently in people of East Asian descent who are past their infant age.

If lactose is not cleaved, it cannot be absorbed, so it travels down the drain from the small to the large intestine. Many of the bacteria found there have the capacity to metabolize lactose, which they will happily convert to acids and gas. For example, *Escherichia coli* has a pathway called *mixed acid fermentation*. One

²Galactose is contained in the glycosyl moieties of many glycoproteins and glycolipids. The enzymes and activated intermediates for the synthesis of galactose from glucose and for its incorporation into glycosyl moieties are widespread among life forms. They predate the emergence of lactose secretion by mammals, and evolution chose to reuse them for lactose utilization.

of the products of this fermentation is formic acid (HCOOH), which is then cleaved by formic acid lyase to H_2 and CO_2 . The decarboxylation of formic acid serves the same purpose as that of pyruvate in ethanolic fermentation, namely, the removal of excess acidity resulting from the fermentation (see slide 3.4.3).

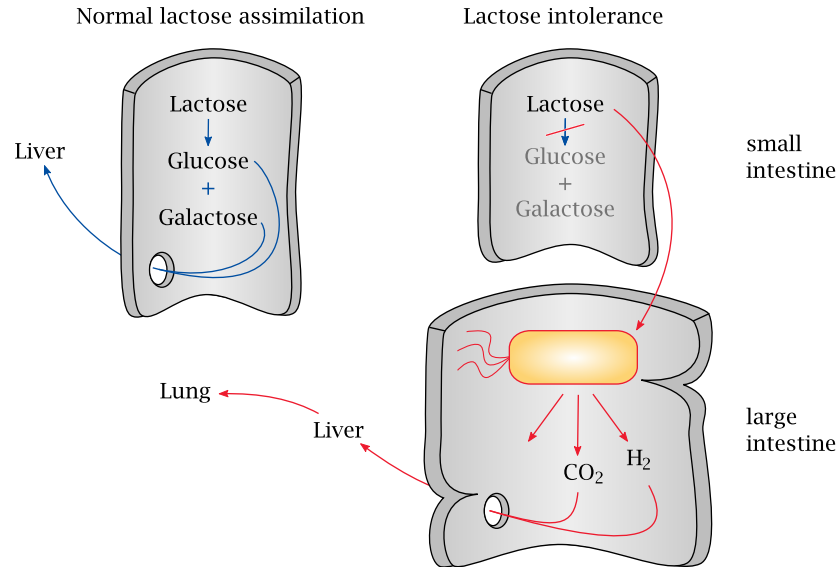

The aberrant fermentation and gas formation leads to abdominal discomfort and diarrhea. Since the environment in the large intestine lacks oxygen, H_2 generated in the bacterial fermentation is not oxidized but instead enters the system as such and is mostly exhaled. An increase in exhaled hydrogen gas provoked by ingesting a test dose of lactose can be used to diagnose the condition.

Treatment consists in omission of lactose in the diet. Milk can be pre-treated with purified bacterial β -galactosidase, rendering it suitable for consumption by lactose-intolerant individuals. Fermented milk products such as yogurt and cheese are depleted of lactose by microbial fermentation and therefore do not pose a problem for lactose-intolerant individuals.



4.4 Explain the pathogenesis of lactose intolerance.

4.3.4 Galactosemia

Notes: Three different enzyme deficiencies in the pathway are subsumed under the name *galactosemia*, which means “galactose in the blood.” All of these are rare; type I is the most common and most severe form. Here, the deficient enzyme is galactose-1-phosphate uridylyltransferase. This leads to a buildup of galactose-phosphate, but also of several other metabolites. The disease becomes manifest in newborns with acute liver failure and is deadly if not promptly diagnosed and treated. In many countries, this enzyme defect is part of neonatal screening programs.

Type	Enzyme deficiency	Accumulating metabolites
I	galactose-1-phosphate-uridylyltransferase	galactose, galactose-1-phosphate, galactitol, galactonate
II	galactokinase	galactose, galactitol
III	UDP-galactose epimerase	galactose-1 phosphate, UDP-galactose

Therapy consists in the removal of galactose from the diet, but even so organ damage develops, most commonly affecting the CNS and, in girls, the ovaries. The residual pathology that develops in spite of the diet is ascribed to the endogenous synthesis of galactose, which proceeds via UDP-glucose and UDP-galactose; the UDP-galactose epimerase reaction is reversible.

For a long time, it was assumed that accumulation of galactose-1-phosphate and phosphate depletion are responsible for cell and organ damage, which is analogous to the pathogenic mechanism in fructose intolerance (see slide 4.2.2). However, this assumption has been thrown into question by the results of animal experiments. When galactose-1-uridylyltransferase is genetically knocked out in mice, these develop a profile of metabolite accumulation that closely resembles human patients, but they do not display any of the pathology observed in humans [8]. What is more, some rare human cases have been reported that show the usual biochemical manifestations, but no clinical signs [9]. The quest for the true cause of the pathology affecting most human patients continues [10, 11].

In the order of the pathway, type II galactosemia comes first, as it involves a defect of galactokinase. In this case, galactose simply does not enter the Leloir pathway at all; it builds up in the blood and is mostly eliminated in the urine. The liver will not be adversely affected. However, there is a common complication elsewhere: the eyes will develop *cataract*, that is, obfuscation of the lenses. This is due to the reduction of galactose to galactitol in the cells of these organs by aldose reductase (see slide 4.4).

The rarest form of galactosemia is due to the defect of UDP-galactose epimerase.

The biochemical pattern is similar to type I, except that UDP-galactose also accumulates, and as in type I, developmental delay seems to occur [12]. In this condition, both the utilization and the synthesis of galactose are inhibited, and it appears necessary to maintain a low level of dietary galactose to supply the synthesis of galactose-containing glycolipids and glycoproteins.



4.5 Describe and discuss type I galactosemia.

4.4 Sorbitol is an intermediate of the polyol pathway

Notes: Sorbitol is not strictly a sugar, since it has no keto or aldehyde group. It is normally a minor component of dietary carbohydrates, but it is also prepared semisynthetically and used as a sweetener. In addition, it is formed in our own

metabolism from glucose in the polyol pathway, which then converts it further to fructose. Note the use of NADPH as a cosubstrate in the first step, and of NAD⁺ in the second. NADP exists mostly in the reduced state, while NAD is mostly oxidized (see slide 9.3.1), which means that both drive the pathway in the indicated direction.

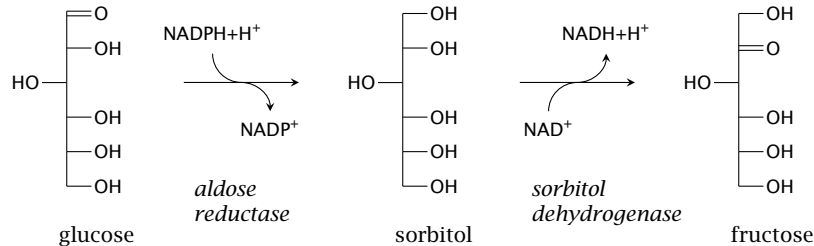

The first enzyme, aldose reductase, is not specific for glucose but can also reduce galactose, which gives rise to galactitol. As stated above, the elevated blood level of galactose in galactosemia type II causes galactitol to accumulate in the lenses; the same occurs with glucose and sorbitol in insufficiently treated diabetes mellitus (see slide 14.5.7). Accumulation of either sorbitol or galactitol causes cataract; this is ascribed to their osmotic activity, which causes cell damage through swelling.

Like the cells in the lens, nerve cells are able to take up glucose in an insulin-independent fashion, and like cataract, nerve cell damage (diabetic polyneuropathy) is a common long-term complication in diabetes. It appears plausible that sorbitol accumulation might also be responsible for this nerve cell damage. Inhibitors of aldose reductase have been developed and have shown promise in animal models of both diabetes and galactosemia, but evidence of clinical effectiveness in humans is scarce.

Conversion of glucose to fructose via the polyol pathway occurs in the *seminal vesicles*, which are part of the male sexual organs, and fructose is found in the sperm fluid. It supplies the sperm cells with fuel in their frantic quest for an oocyte; the advantage of this somewhat unusual source of energy may be that fructose will not be pilfered by the other tissues the sperm fluid will get into contact with.

Now, if sperm cells require fructose to sustain their motility, one might expect that prevention of fructose synthesis with aldose reductase inhibitors would disrupt male fertility and thus provide the long-sought pill for males. However, I have not seen any experimental studies on this subject.

4.5 Answers to practice questions

4.1: See table in section 4.1.

4.2: Fructose is degraded by fructokinase, which produces fructose-1-phosphate, aldolase B, which produces dihydroxyacetone phosphate and glyceraldehyde, and glyceraldehyde kinase. Fructose intolerance is due to a homozygous enzyme defect in aldolase B, which causes fructose-1-phosphate to accumulate and free phosphate to be depleted. Fruc-

tosemia results from a defect of fructokinase and causes a buildup of free fructose in blood and urine.

4.3: Galactose undergoes phosphorylation to the 1-phosphate by galactokinase. Galactose-1-phosphate is exchanged for glucose-1-phosphate by galactose-1-phosphate uridylyltransferase, which uses UDP-glucose as its other substrate. Glucose-1-phosphate is converted to the 6-phosphate by phosphoglucomutase, whereas UDP-galactose epimerase regenerates UDP-glucose.

4.4: Lactose intolerance results from a deficiency of intestinal lactase. Ingested lactose cannot be cleaved and taken up in the small intestine and therefore reaches the large intestine, where it is metabolized by bacteria. Changes in bacterial metabolism, including increased gas formation, gives rise to abdominal discomfort and diarrhea.

4.5: Type I galactosemia is caused by a defect of galactose-1-phosphate uridylyltransferase. Metabolites upstream of the deficient enzyme accumulate, as do the aberrant conversion products galactitol and galactonate. The disease causes potentially severe pathology in the liver and other organs, but the biochemical mechanism of organ damage is not precisely understood.

Chapter 5

Pyruvate dehydrogenase and the citric acid cycle

5.1 Overview

In the complete degradation of pyruvate, pyruvate dehydrogenase (PDH) and the citric acid cycle perform the oxidation of all substrate carbon to CO_2 . The hydrogen is retained in reduced form; it is subsequently oxidized in the respiratory chain.

5.1.1 Pyruvate degradation occurs in the mitochondria

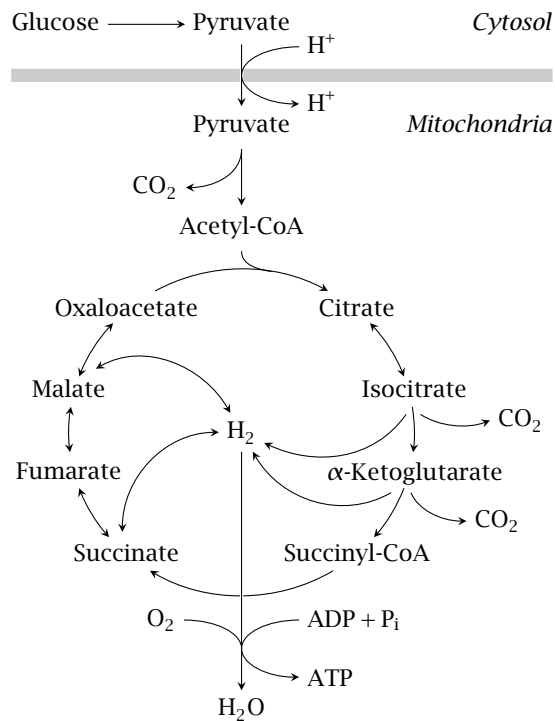

Notes: Pyruvate is produced by glycolysis in the cytosol, while PDH and all subsequent degradative steps are located in the mitochondria. Therefore, pyruvate needs to be transported from the cytosol to the mitochondrial matrix.

The outer mitochondrial membrane contains *porins*, which are membrane proteins that form non-specific pores and allow free permeation of most small metabolites, including pyruvate. In contrast, the inner mitochondrial membrane is much more restrictive, and it is permeable to only those metabolites for which it contains specific carrier systems. The pyruvate carrier is an active transporter that co-transporters pyruvate and a proton.¹

Red blood cells and blood platelets lack mitochondria and accordingly cannot degrade pyruvate. These cells reduce pyruvate to lactate, which they then release into the bloodstream (see slide 3.4.2).



5.1 Summarize the metabolite transport properties of the inner and outer mitochondrial membranes.

5.2 Structure and function of pyruvate dehydrogenase

Pyruvate dehydrogenase is a large and complex molecule with interesting structural, catalytic and regulatory properties.

5.2.1 The PDH reaction occurs in three successive steps that are catalyzed by three different subunits

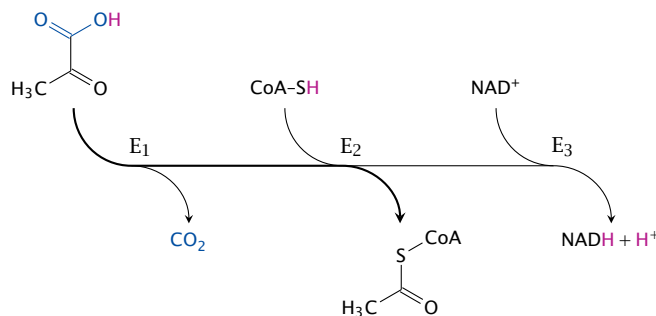

Notes: The overall reaction catalyzed by PDH is as follows:

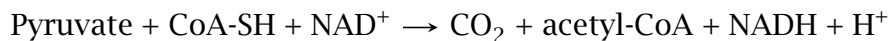

This reaction does not occur all at once; instead, it is carried out as a sequence of group transfers and redox steps by three different catalytic subunits. These subunits are named according to the specific partial reactions they catalyze:

1. pyruvate dehydrogenase² removes CO₂,

¹Alternatively, we might say that pyruvate is exchanged for an OH⁻ ion; the net effect is virtually the same.

²You will notice that the name “pyruvate dehydrogenase” is ambiguous, denoting both the entire complex and the first subunit.

2. dihydrolipoyl transacetylase transfers the remainder of the substrate to coenzyme A, and
3. dihydrolipoyl dehydrogenase transfers the H_2 that was retained in the preceding steps to NAD^+ .

Instead of using these explicit names, we will here adopt a commonly used shorthand notation and refer to them as E_1 , E_2 , and E_3 , respectively.

5.2.2 The structural organization of the PDH complex

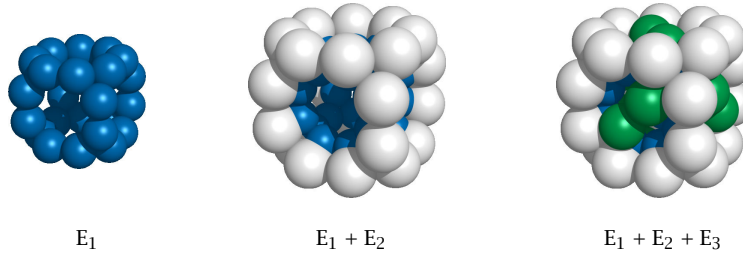

Notes: Each pyruvate dehydrogenase complex contains multiple copies of each of the three enzyme subunits. E_1 and E_2 are present in 24 copies each. The *E. coli* enzyme contains 12 copies of E_3 , as shown in this illustration, whereas 24 copies are found in the mammalian enzyme. In addition, the complex also contains regulatory kinase and phosphatase subunits (see slide 5.3.2).

Within this large assembly, each E_1 subunit is still located close to one or more subunits of the E_2 and E_3 types. The reaction intermediates thus need to travel only a short distance from one active site to the next, which increases the overall catalytic efficiency. Generally speaking, high substrate throughput is the key advantage of multi-enzyme complexes over a series of individual enzymes.³

5.2.3 A lipoamide tether guides the substrate from one active site to the next

Notes: The catalytic efficiency of PDH is further increased by another neat trick: The intermediate substrates become covalently attached to lipoamide. This coenzyme is covalently attached to E_2 , but due to its long, flexible linker can reach into the active sites of adjacent E_1 and E_3 subunits as well. The lipoamide tether thus guides the substrate from one active site to the next, preventing it from leaving until it has completed the course.



5.2 Describe the structural organization of pyruvate dehydrogenase, and explain the role of the covalently bound dihydrolipoyl moiety.

³The pyruvate dehydrogenase complex remains intact when purified from cell extracts. With some other enzymes, there is evidence that they form functional complexes *in vivo*, even though they emerge from purification procedures as individual and functional molecules. For example, malate dehydrogenase and citrate synthase may associate *in vivo*, so that oxaloacetate may pass directly from one to the other [13]. Another intriguing example is the association of glycolytic enzymes with the outer surface of the mitochondria [14].

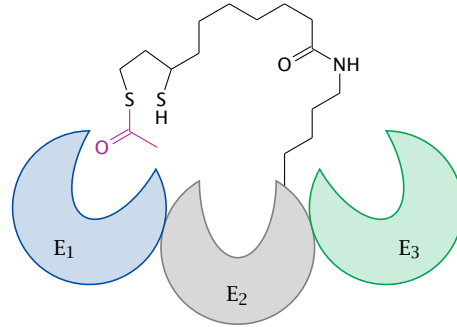

5.2.4 The pyruvate dehydrogenase reaction involves multiple coenzymes

Notes: Each of the subunits E₁-E₃ requires a coenzyme to work its particular magic. In addition, two cosubstrates are also used, namely, NAD⁺ and coenzyme A.⁴

Coenzyme	Subunit	Role in catalysis
thiamine pyrophosphate	E ₁	provides a carbanion for nucleophilic attack on the substrate
lipoamide	E ₂	transfers substrate to coenzyme A, retains hydrogen
flavin adenine dinucleotide (FAD)	E ₃	transfers H ₂ from lipoamide to NAD ⁺

5.2.5 Thiamine pyrophosphate forms a carbanion

Notes: The coenzyme thiamine pyrophosphate (TPP), which is derived from thiamine (vitamin B₁), is associated with the E₁ subunit of PDH. In cooperation with an aspartate residue in the active site, TPP forms a carbanion, that is, a negative charge on a carbon atom. The TPP carbanion is resonance-stabilized; an electron can move back and forth between the carbanion and the neighboring cationic nitrogen.

Carbanions are very powerful nucleophiles, and the TPP carbanion functions as such in the decarboxylation of pyruvate.

⁴Yes, strictly speaking, coenzyme A is a cosubstrate, since it is transformed from one state to another in the reaction; a true coenzyme should emerge from the reaction unchanged, just like the enzyme. As you can see, the distinction between coenzymes and cosubstrates is not strictly maintained in the traditional nomenclature.

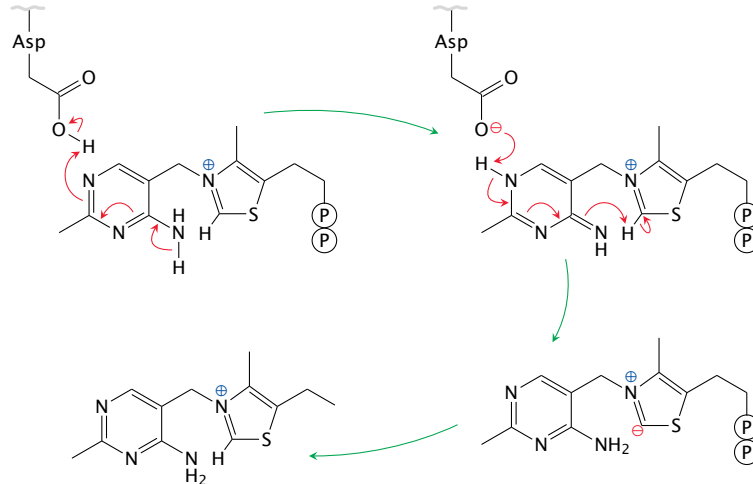

5.2.6 Decarboxylation of pyruvate by E₁

Notes: The TPP⁵ carbanion attacks the keto group of pyruvate, which leads to a covalent intermediate from which CO₂ is cleaved. This yields another carbanion, now located within the hydroxyethyl group that is the remainder of the substrate. This new carbanion, which is again resonance-stabilized by TPP, sets the stage for the next step in the reaction.

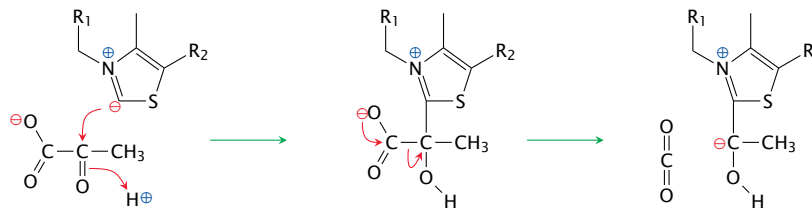

5.2.7 Release of acetyl-CoA and disposal of hydrogen

Notes: The plot continues from the previous slide at the top right. The carbanion on the hydroxyethyl group attacks the disulfide bond of lipoamide. The entire substrate is then cleaved from TPP and carried by lipoamide to E₂, where it is transferred to coenzyme A and released as acetyl-CoA. Lipoamide is reduced to dihydrolipoamide in the process; it is reoxidized by E₃, which transfers the hydrogen to NAD⁺, using FAD as an intermediate carrier. This concludes the pyruvate dehydrogenase reaction.



5.3 Give an overview of the three steps involved in the PDH reaction.

⁵Note that only the thiazole ring of TPP is shown in this slide; its second ring is represented by R₁.

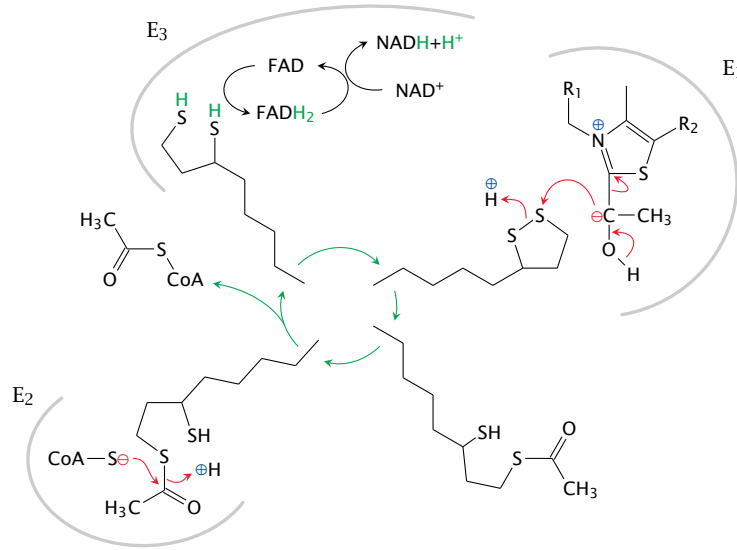

5.3 Regulation of pyruvate dehydrogenase

We had seen earlier that enzymes may be regulated by allosteric control or through phosphorylation (section 2.5). Pyruvate dehydrogenase exemplifies both mechanisms.

5.3.1 Alternate metabolic destinations of pyruvate

1. conversion to acetyl-CoA by PDH for complete degradation or for synthesis of fatty acids and cholesterol
2. carboxylation to oxaloacetate, for use in gluconeogenesis or in the citric acid cycle
3. synthesis of amino acids, e.g., transamination to alanine
4. reduction to lactate

Notes: Pyruvate is used in several different pathways. All these pathways, including PDH, must be coordinated and regulated in order to achieve the proper flow rates along each of them. In the case of pyruvate dehydrogenase, the flow rate is controlled by several feedback and feed-forward mechanisms.

5.3.2 Regulation of PDH by allosteric effectors and by phosphorylation

Notes: Pyruvate dehydrogenase is allosterically activated by fructose-1,6-bisphosphate and inhibited by NADH and acetyl-CoA.

Phosphorylation of PDH is mediated by a special regulatory enzyme, pyruvate dehydrogenase kinase. This enzyme is part of the PDH multienzyme complex. Phosphorylation inactivates pyruvate dehydrogenase. The kinase is, in turn, sub-

ject to allosteric activation by NADH and acetyl-CoA, while it is inhibited by ADP, NAD⁺ and by free coenzyme A.

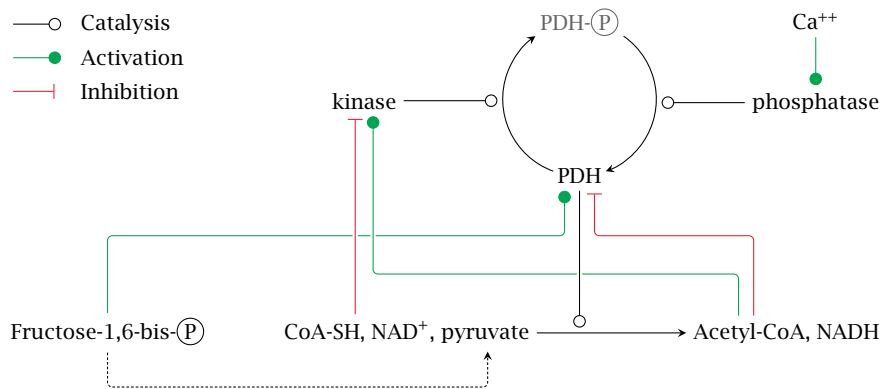

Phosphorylation is reversed, and the activity of pyruvate dehydrogenase restored by a protein phosphatase, which is also associated with the pyruvate dehydrogenase complex.

All of the above regulatory effects make good physiological sense. NADH and acetyl-CoA inhibit PDH, which means that the enzyme will slow down when its products accumulate. Such feedback inhibition is a straightforward way to link the activity of a pathway to the metabolic requirements it serves. On the other hand, pyruvate, NAD⁺ and fructose-1,6-bisphosphate apply feed-forward activation—as more substrate arrives, the enzyme should gather speed.

One more interesting detail is that the PDH phosphatase is activated by calcium ions. Calcium ions also trigger the contraction of muscle cells. Concomitant activation of PDH anticipates the need to replace the ATP that will be consumed in the contraction.



5.4 Summarize the regulation of pyruvate dehydrogenase.

5.4 The citric acid cycle

Almost all carbon that accrues in carbohydrate degradation is converted by PDH to acetyl-CoA. The latter metabolite is also formed, by different enzymes, in the degradation of fatty acids and of ketogenic amino acids, and it therefore is a central hub in energy metabolism. The next step toward complete oxidation is the citric acid cycle, also referred to as the Krebs cycle or the tricarboxylic acid cycle (TCA cycle for short).

The basic idea of the TCA cycle consists in releasing the substrate carbon as CO₂, while retaining the substrate hydrogen for “cold combustion” in the respiratory chain. However, a closer look reveals that something is missing from this description.

5.4.1 The overall reaction of the TCA cycle: does it add up?

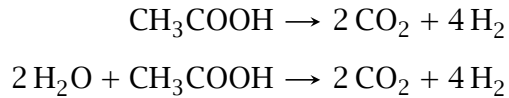

Notes: While the substrate carbon enters the TCA cycle as acetyl-CoA, the coenzyme A moiety is simply hydrolyzed off in the very first reaction; therefore, with only a little sleight of hand, we can neglect coenzyme A and substitute acetate for acetyl-CoA as the substrate.

If we look back at figure slide 5.1.1, we see that the TCA cycle produces four molecules of H_2 and two molecules of CO_2 . Now, if we attempt to balance our single acetate substrate with these amounts of CO_2 and H_2 , we see that we are short 4 hydrogen and 2 oxygen atoms on the left side. However, we can balance the equation by adding two molecules of water.⁶

What this means is that half of the H_2 produced in the TCA cycle is gained by the reduction of hydrogen from water. The water-derived oxygen that accrues in the process is used to complete the oxidation of the acetate carbon. Hydrogen derived from both water and acetate is then re-oxidized in the respiratory chain to generate ATP.

The energy yield of the TCA cycle itself, in terms of directly generated energy-rich phosphoanhydride bonds, is very modest—just one molecule of GTP, equivalent to one ATP, is generated for each molecule of acetyl-CoA degraded, compared to approximately 15 in the respiratory chain. This comparison shows that the TCA cycle's main contribution to ATP generation is to provide H_2 for the respiratory chain.

5.4.2 The citrate synthase reaction

Notes: The first reaction in the TCA cycle is catalyzed by citrate synthase. It is mediated by acid-base catalysis; abstraction of a proton from the methyl group of acetyl-CoA by an aspartate residue in the active site converts acetyl-CoA to an enol form, which then attacks the carbonyl group of oxaloacetate. The reaction is assisted by two histidine residues and pulled forward by the subsequent hydrolysis of citryl-CoA. Figure drawn after a scheme given in [15].

⁶Where exactly do the two water molecules enter the TCA cycle? For one of them, it is obvious (see step 7 in slide 5.4.3). However, the second one is a bit harder to spot. Hint: it is *not* the H_2O that hydrolyzes off the acetyl-CoA in the citrate synthase reaction, since that is already accounted for by substituting acetate for acetyl-CoA in our simplified reaction scheme.

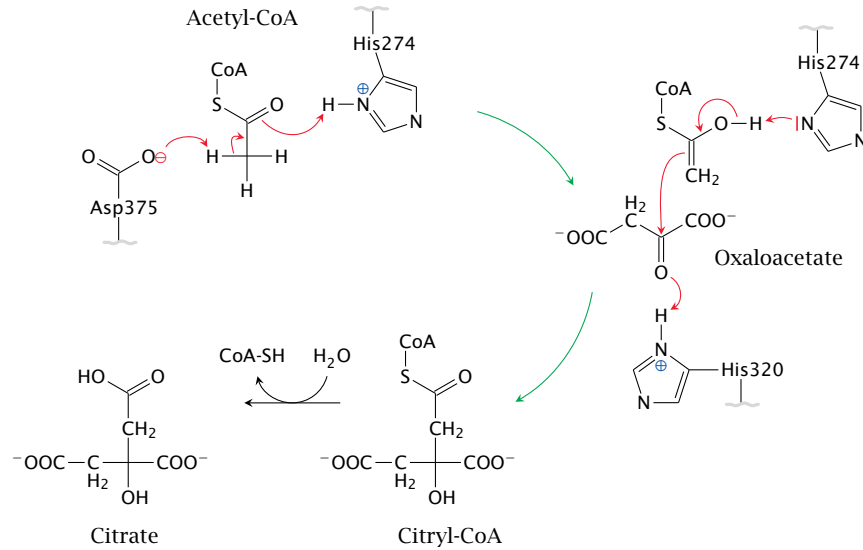

5.4.3 Reactions in the TCA cycle: from citrate to oxaloacetate

Notes: The paragraph numbers below correspond to those of the reactions in the figure. The first reaction in the figure is the second in the cycle overall, which is why it gets the number 2.

2. The hydroxyl group in the newly formed citrate is shifted to an adjacent carbon to yield isocitrate. This reaction is catalyzed by citrate isomerase and involves the transient elimination of water across the two carbons involved; the water is then added back in the reverse orientation.

3. Isocitrate is decarboxylated and dehydrogenated by isocitrate dehydrogenase, which yields α -ketoglutarate. In contrast to the pyruvate dehydrogenase reaction, dehydrogenation precedes decarboxylation. The dehydrogenated intermediate is known as oxalosuccinate.

4. α -Ketoglutarate is converted to succinyl-CoA by α -ketoglutarate dehydrogenase. This catalytic mechanism of this enzyme is completely analogous to that of pyruvate dehydrogenase.

5. Succinyl-CoA is converted to succinate by succinate thiokinase, and GDP is concomitantly phosphorylated to GTP. From the mechanism of the glyceraldehyde-3-phosphate dehydrogenase reaction (Figure 3.3.5), we already know that thioester bonds are energy-rich and can drive the phosphorylation of carboxylic acids. A carboxylic acid phosphate, succinylphosphate, also occurs as an intermediate in the succinate thiokinase reaction. As is the case with 1,3-bisphosphoglycerate, the phosphate group is subsequently transferred to a nucleotide diphosphate. While succinate thiokinase uses GDP rather than ADP, the amounts of energy involved are virtually the same.

6. Succinate is dehydrogenated across the $\text{CH}_2\text{-CH}_2$ bond by succinate dehydrogenase, which yields fumarate. The coenzyme used in this reaction is flavin adenine dinucleotide (FAD). As a rule of thumb, you can assume that FAD is used

in the dehydrogenation of CH–CH bonds, whereas either NAD^+ or NADP^+ are used in the dehydrogenation of CH–OH bonds. While all other enzymes in the TCA are in aqueous solution in the mitochondrial matrix, succinate dehydrogenase is bound to the inner surface of the inner mitochondrial membrane; it is identical with complex II of the respiratory chain (see slide 6.4).

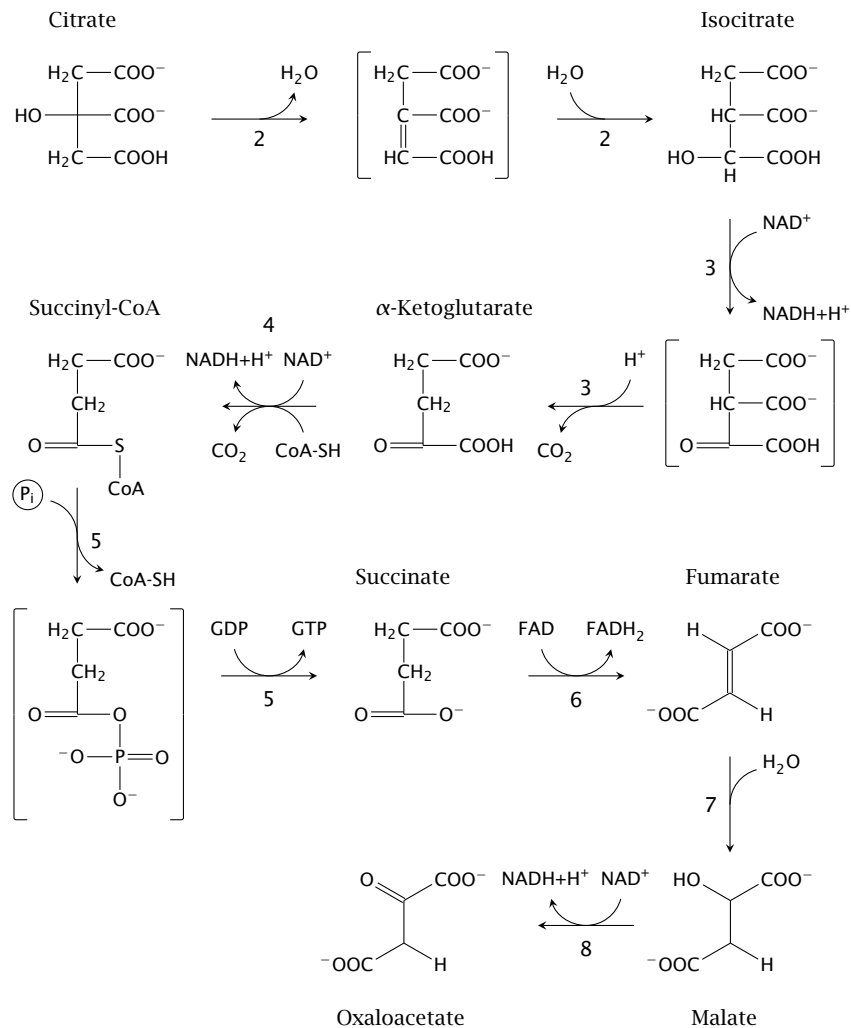

7. Fumarate is hydrated to L-malate by fumarase.

8. Malate is dehydrogenated by malate dehydrogenase to oxaloacetate. This step regenerates oxaloacetate, which can again enter the citrate synthase reaction, and thus completes the cycle.



5.5 Do we *really* have to know the structures?

5.4.4 α -Ketoglutarate dehydrogenase resembles PDH

Notes: As pointed out above, α -ketoglutarate dehydrogenase uses the same catalytic mechanism as pyruvate dehydrogenase. The similarity is reflected in a high degree of homology between the subunits of the two enzymes. If you look closely

at the PDH mechanism (Figure 5.2.1), you will see that the reactions carried out by the final subunit (E_3) will be identical in both cases, since E_3 comes into play when only hydrogen is left but the rest of the substrate has already been disposed of. Indeed, the two multienzyme complexes share the very same E_3 protein; only E_1 and E_2 are specific for the respective substrates. The same E_3 subunit occurs yet again in an analogous multienzyme complex that participates in the degradation of the branched chain amino acids (slide 12.4.4), as well as in the glycine cleavage system (slide 15.2.6).

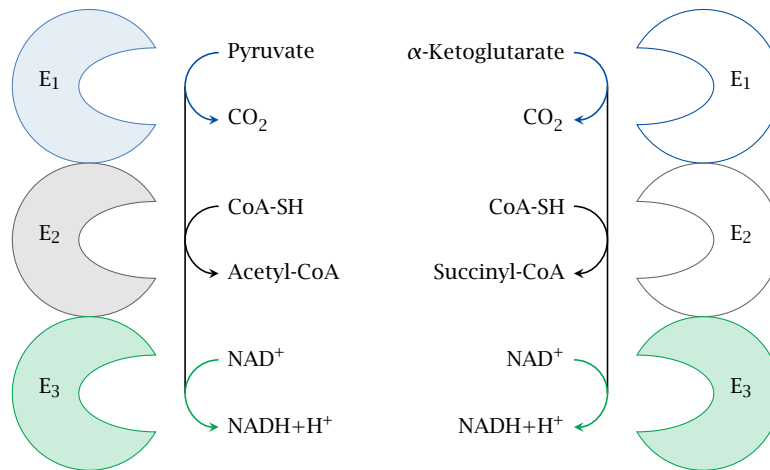

5.5 Regulation of the citric acid cycle

- ATP and NADH inhibit isocitrate dehydrogenase
- NADH inhibits α -ketoglutarate dehydrogenase
- High levels of NADH will lower the oxaloacetate concentration, which limits citrate synthase activity

Notes: Acetyl-CoA is not only utilized for complete oxidation but also for the biosynthesis of fatty acids, cholesterol, and ketone bodies. Therefore, the activity of the citric acid cycle must be balanced with those of the various synthetic pathways. This regulation is mainly exercised by NADH, the major direct product of the TCA, and by ATP, the ultimate product of complete substrate oxidation via the TCA and the respiratory chain.

It is noteworthy that the equilibrium of the malate dehydrogenase reaction favors malate. The concentration of oxaloacetate is thus quite low, and it will be lowered further if NADH accumulates. This limits the rate of the initial reaction of the TCA, that is, the synthesis of citrate, and it also detracts from the free energy of that reaction. To make citrate synthesis go forward, it is necessary to sacrifice the energy-rich thioester bond in the citryl-CoA intermediate, which in contrast to succinyl-CoA is simply hydrolyzed and not used toward the synthesis of GTP or ATP.

The mitochondrion contains two isozymes of isocitrate dehydrogenase; one uses NAD^+ and the other NADP^+ as the cosubstrate. Intriguingly, the feedback inhibition by NADH and ATP applies only to the NAD^+ -dependent isozyme, but not to the NADP^+ -dependent one.

In cells with high TCA activity, such as heart and skeletal muscle, the NADP^+ -dependent variant is actually present at higher activity than the NAD^+ -dependent one. How, then, is the NADP^+ -dependent enzyme regulated? This regulation appears to occur in coordination with the flow through the respiratory chain and the proton-motive at the inner mitochondrial membrane. The mechanism is quite fascinating and is discussed at the end of the following chapter.



5.6 Summarize the regulation of the TCA cycle.

5.6 Reactions that divert and replenish TCA cycle intermediates

Several metabolites in the citric acid cycle are also substrates in biosynthetic pathways, for example those for heme or various amino acids, and through these pathways are drained from the cycle. When this occurs, they will need to be replenished. Similarly, when the workload of a cell and its ATP demand increase, the TCA cycle must then process acetyl-CoA at an accelerated rate, which requires an increase in the pool of TCA cycle intermediates.

The first thing to note is that just feeding more acetyl-CoA into the TCA cycle does *not* address this problem, since acetyl-CoA simply offsets the two CO_2 molecules that are lost in subsequent reactions in the cycle. Instead, we need a net supply of any of the intermediates with four or more carbon atoms that function catalytically rather than as substrates.

One important and abundant source of TCA cycle intermediates is the pyruvate carboxylase reaction, which makes oxaloacetate from pyruvate (slide 7.2.4). Often, however, the oxaloacetate thus obtained is immediately diverted again toward glucose synthesis (gluconeogenesis). In this situation, amino acids become the major net source of TCA cycle intermediates (see chapter 12).

5.7 Answers to practice questions

5.1: Mitochondria have two membranes. The outer membrane contains porins, which non-selectively allow permeation of small metabolites. The inner membrane only contains specific carrier proteins, which restrict transport to their cognate substrates.

5.2: Pyruvate dehydrogenase is a multienzyme complex that contains multiple copies of three different catalytic subunits (E_1 - E_3), as well as two regulatory subunits. The dihydrolipoyl moiety is bound to the E_2 subunit; it accepts the substrate in the active site of E_1 and guides it along to the active sites of E_2 and E_3 .

5.3: In the active site of E_1 , thiamine pyrophosphate (TPP) cooperates with an aspartate residue to form a carbanion, which performs nucleophilic attack on the carbonyl group of pyruvate and thereby initiates its decarboxylation. The remainder of the substrate initially remains bound to TPP, but is then transferred to lipoamide as an acetyl group.

In the active site of E_2 , the acetyl group is transferred from lipoamide to coenzyme A. Lipoamide becomes reduced to dihydrolipoamide in the process; it is reoxidized by E_3 , which transfers the H_2 to NAD^+ .

5.4: PDH is subject to allosteric activation by fructose-1,6-bisphosphate and to inhibition by acetyl-CoA and NADH. It is also subject to inhibition by phosphorylation, which in turn is activated by the products and inhibited by the substrates of PDH.

5.5: Yes. Metabolism without structures is as useful as memorizing phone books (or probably even less so).

5.6: NAD-dependent isocitrate dehydrogenase is inhibited by ATP and NADH. The latter also inhibits α -ketoglutarate dehydrogenase and shifts the malate dehydrogenase equilibrium away from oxaloacetate, which slows down the citrate synthase reaction.

Chapter 6

The respiratory chain

6.1 Introduction

In the respiratory chain, the NADH and FADH₂ that was accumulated in the preceding degradative pathways is finally disposed of by reacting it with molecular oxygen. The free energy of this “cold combustion” is used to generate ATP. The amount of ATP generated in the respiratory chain far exceeds the modest quantities produced in the upstream pathways; this is the reason why only aerobic metabolism enables us to sustain physical exertion for extended periods of time.

The workings of the respiratory chain are quite different from all other pathways in human metabolism. Each of those other pathways consists of a succession of discrete enzymatic reactions. Inasmuch as these pathways contribute to the production ATP, the energy is always passed from one energy-rich bond to the next, with a newly created phosphoanhydride bond in ATP as the final recipient. In contrast, the respiratory chain combines chemical reactions with physical forces that are not pinned down to individual molecules, and the energy is stored and converted in novel ways.

6.2 Overview

Notes: The respiratory chain involves four large protein complexes (I-IV) as well as ATP synthase (AS). All of these are embedded in the inner mitochondrial membrane. Coenzyme Q (Q) and cytochrome C (C) are diffusible electron carriers.

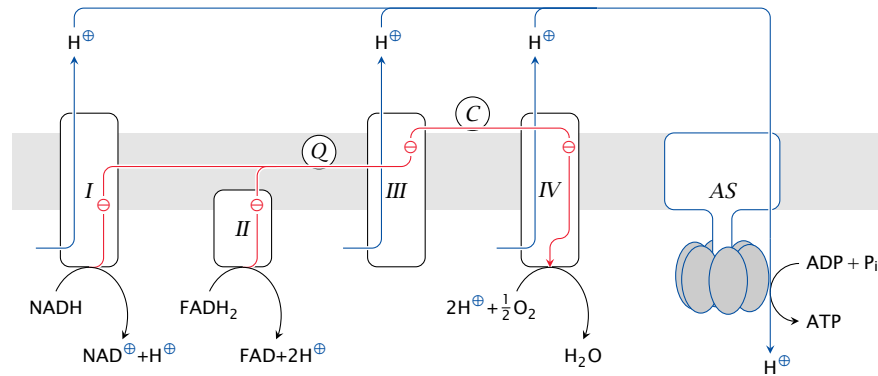

In this scheme, the mitochondrial matrix is below the membrane, whereas the cytosol is above it. The reactions carried out in the chain are explained below. Note that the reactants in this scheme are not stoichiometrically balanced.

6.2.1 Functional stages in the respiratory chain

1. H₂ is abstracted from NADH+H⁺ and from FADH₂
2. The electrons obtained with the hydrogen are passed down a cascade of carrier molecules located in complexes I-IV, then transferred to O₂
3. Powered by electron transport, complexes I, III, and IV expel protons across the inner mitochondrial membrane
4. The expelled protons reenter the mitochondrion through ATP synthase, driving ATP synthesis

Notes: The electron transport chain (ETC) comprises complexes I-IV. Hydrogen is acquired by complexes I and II from NADH and FADH₂, respectively. The electrons are then passed down the chain to complex IV, which transfers them to molecular oxygen; the reduced oxygen then reacts with protons to yield water.

Complexes I, III and IV extract energy from the electron flow and use it to expel protons across the membrane. For each electron migrating down the chain, *multiple* protons are pumped out of the mitochondrion. The protons accumulated outside the mitochondrion are allowed back in through ATP synthase. This protein is a *molecular motor*, driven to rotate by the flow of protons through it into the mitochondrial matrix. The rotary motion of ATP synthase in turn drives the synthesis of ATP from ADP and phosphate.¹

¹As mentioned before, the porins in the outer mitochondrial membrane are permeable for most small molecules and ions, and thus the proton concentration in the space between the two mito-

If you think that all this sounds somewhat strange and vague, you are quite right—but don't let that trouble you. The purpose of this overview is only to divide and conquer, to break up the overall process into manageable parts that we can then tackle in detail in their turn.

6.3 ATP synthesis can be separated from electron transport

The first thing to note about electron transport and ATP synthesis is that they can be experimentally separated from one another. So-called uncoupling agents allow the observation of electron transport without ATP synthesis. On the other hand, ATP synthesis works without electron transport if a proton gradient is created in some other way.

6.3.1 Uncoupling proteins dissipate the proton gradient

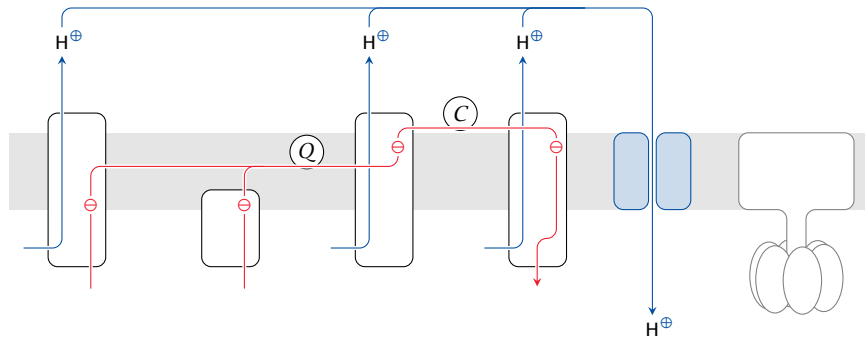

Notes: Uncoupling proteins are membrane proteins, also embedded in the inner mitochondrial membrane, that passively transport protons, allowing them to bypass ATP synthase. Electron transport and hydrogen oxidation—and, upstream of it, degradation of energy-rich substrates—will continue, but ATP synthesis will cease; the energy that would have gone into ATP synthesis is simply dissipated as heat.

Uncoupling proteins are found in particularly high concentration in the mitochondria of *brown fat tissue*, which differs from the more abundant white fat tissue by its high density of mitochondria.² Brown fat tissue serves the purpose of producing heat, by way of simply oxidizing fat without ATP production. The physiological significance is discussed in slide 10.3.8.

chondrial membranes equilibrates readily with the cytosol. The proton concentration gradient that powers ATP synthesis therefore exists across the inner mitochondrial membrane only.

²The cytochromes of the abundant mitochondria give this tissue its brown color; the white color of regular fat tissue tells us that its density of mitochondria must be low.

6.3.2 The uncoupling action of dinitrophenol

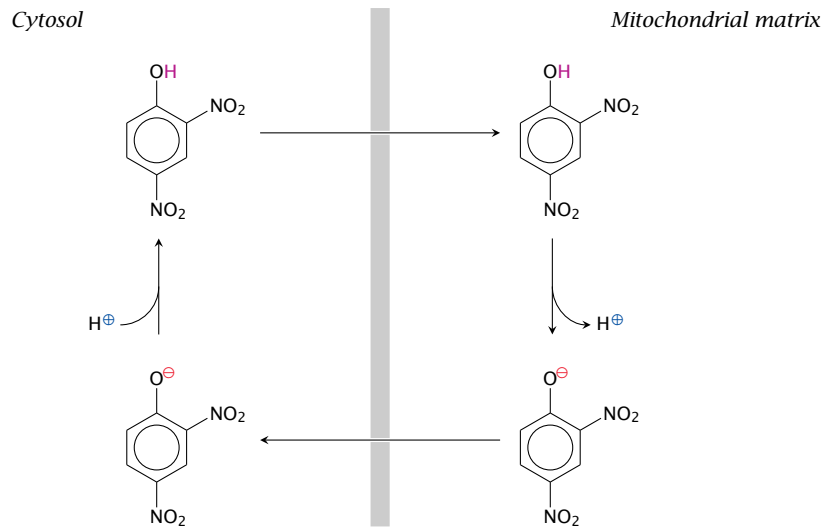

Notes: The synthetic compound dinitrophenol can diffuse across the inner mitochondrial membrane in both its protonated and unprotonated form. It can therefore carry protons into the mitochondrion, thereby dissipating the driving force for ATP synthase.³ Just like uncoupling proteins do in brown fat tissue, dinitrophenol will induce the burning of fat or other substrates and the production of heat—but in the mitochondria everywhere, not just in brown fat tissue. In the 1930s, dinitrophenol was used as a drug for losing excess body weight. It worked, too, but cases of fatal hyperthermia and other side effects caused the speedy discontinuation of this use. Wikipedia reports that the drug remains popular among bodybuilders, however, which seems of a piece with other reckless self-medication practices among the followers of this cult.

6.3.3 The Racker experiment: bacteriorhodopsin can drive ATP synthase

Notes: The effects of uncouplers show that electron transport can occur in the absence of ATP synthesis. On the other hand, ATP synthesis will occur in the absence of electron transport if a proton gradient is sustained in some other way. This was elegantly demonstrated by Ephraim Racker, who incorporated ATP synthase into liposomes along with *bacteriorhodopsin*, a membrane protein from the halophilic (that is, salt-loving) bacterium *Halobacterium halobium*.

Bacteriorhodopsin is a very unusual protein that functions as a light-driven proton pump: just shining light on it makes it pump protons across the membrane. In our experiment, illuminating the sample will make bacteriorhodopsin pump

³Dinitrophenol is a hydrophobic molecule, and it therefore is not surprising that it can cross membranes in protonated form. However, the high membrane permeability of its deprotonated, negatively charged form is unusual. This is related to the two electron-withdrawing nitro groups, which cause the negative charge to be highly delocalized; this prevents the molecule from attracting a tightly bound hydration shell that otherwise would interfere with its permeation across the membrane.

protons into the liposome. This will crank the ATP synthase and make it synthesize ATP from ADP and ionic phosphate.

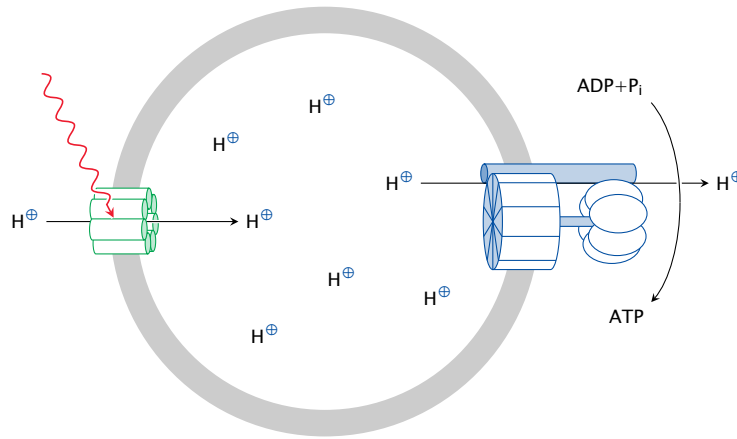

Note that the orientation of both proteins shown here is inside-out relative to that found in their natural host membranes. Therefore, protons will here accumulate on the inside, and ATP synthesis proceed on the outside; this is the reverse of the situation in vivo.

The theoretical significance of these experimental findings is that, although the electron transport chain and ATP synthase reside in the same membrane and in close proximity, the proton gradient is the only required functional link between them. The electron transport chain generates the proton gradient, whereas ATP synthase puts it to work and thereby dissipates it. Because of this clear distinction, we can safely examine these two functions separately from each other.



6.1 Explain the theoretical implications of dinitrophenol uncoupling of the respiratory chain, and of the Racker experiment.

6.4 Molecules in the electron transport chain

Notes: This slide shows the structures of the four respiratory chain complexes that form the respiratory chain.⁴ The gray rectangle represents the inner mitochondrial membrane. Among the redox cofactors, yellow and red blobs represent iron sulfur clusters. Organic rings (black) with red balls (iron atoms) in the center are hemes; other organic rings are flavins or ubiquinone (Q). The blue ball next to one of the hemes in complex IV is the copper ion in its active site. Each of the four complexes has a specific role in the electron transport process:

1. Complex I accepts hydrogen from $\text{NADH} + \text{H}^+$ and is therefore also called NADH dehydrogenase. The NADH is oxidized back to NAD^+ and thereby readied for the next round of reduction in the TCA cycle or by pyruvate dehydrogenase. The hydrogen is split into electrons and protons. The electrons travel along a string of redox cofactors that traverses the entire protein complex and are then transferred to the small, membrane-resident carrier molecule known as ubiquinone

⁴Drawn from [3m9s.pdb](#), [2fbw.pdb](#), [3cx5.pdb](#), [2zxx.pdb](#), and [3cyt.pdb](#), after a figure in [16].

or coenzyme Q, which passes them on to complex III. Powered by this electron migration, complex I ejects four protons across the membrane.

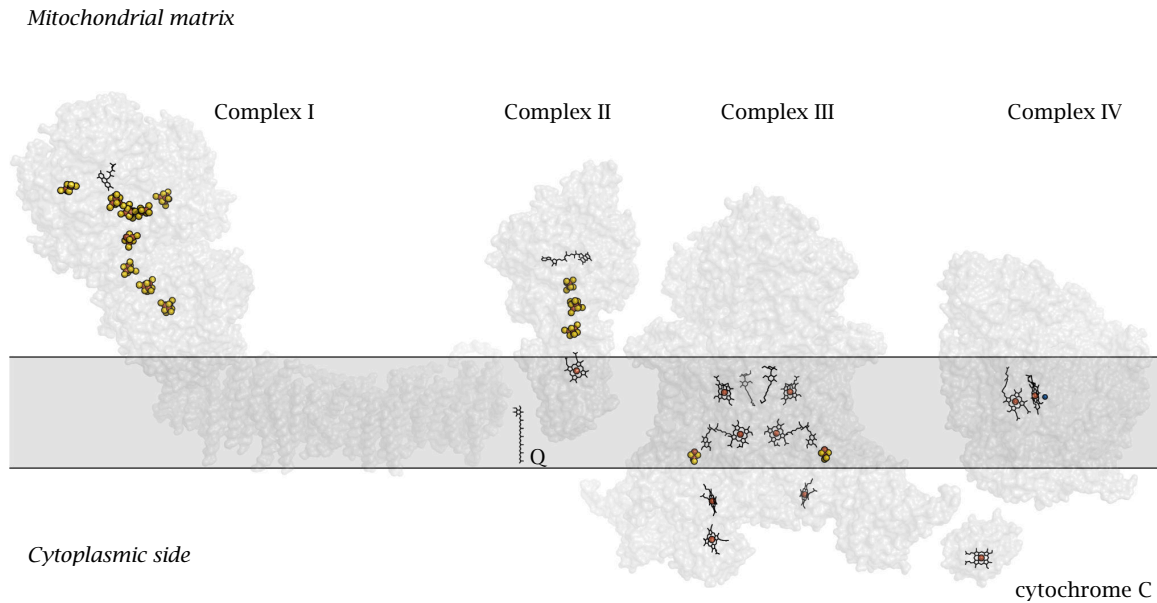

2. Complex II accepts hydrogen from FADH_2 , which was reduced by succinate. It was mentioned in slide 5.4.3 that complex is identical with succinate dehydrogenase, which illustrates that the two pathways are really functionally one. The electrons are again transferred to coenzyme Q; however, no proton extrusion occurs at complex II.⁵

3. Complex III reoxidizes coenzyme Q and expels more protons. According to the coenzyme Q cycle model presented below, four protons are being expelled at this stage for each pair of electrons transported, but in some sources the number of protons expelled is given as two; this illustrates that there still is some uncertainty about the mechanistic details. Having performed their work at complex III, the electrons are delivered to the small electron carrier protein cytochrome C.

4. Complex IV accepts the electrons from cytochrome C and is accordingly also called cytochrome C oxidase. The electrons are transferred to oxygen, and the considerable free energy associated with this electron transfer step is used to expel up to four protons from the mitochondrial matrix.

Electrons do not occur in free form but are always part of molecules or ions.⁶ Therefore, to make electrons flow along the prescribed path along complexes I–IV, these proteins must provide functional groups that are able to accept and donate electrons. These groups must be closely spaced, within a few Angstroms of each other, to allow for efficient electron transfer. Furthermore, to persuade

⁵In contrast to complexes I, III and IV, complex II does not span the entire membrane; this readily suggests that proton translocation will not occur here.

⁶Electrons *do* occur free as β particles in ionizing β radiation. However, to escape capture by molecules, β particles must possess an amount of energy much higher than those available in biochemical or other chemical reactions. When β particles impinge on a solid body, they dissipate their energy by breaking up any molecules in their path into radicals or ions, until they are finally captured again.

the electrons to flow in the right direction, the successive transitions must be exergonic, that is, their free energy (ΔG) must be negative.

In the figure above, you can see a multitude of redox cofactors, neatly spaced along the protein molecules, that function as “stepping stones” for the migrating electrons. These prosthetic groups fall into various structural classes.

6.4.1 Iron-containing redox cofactors

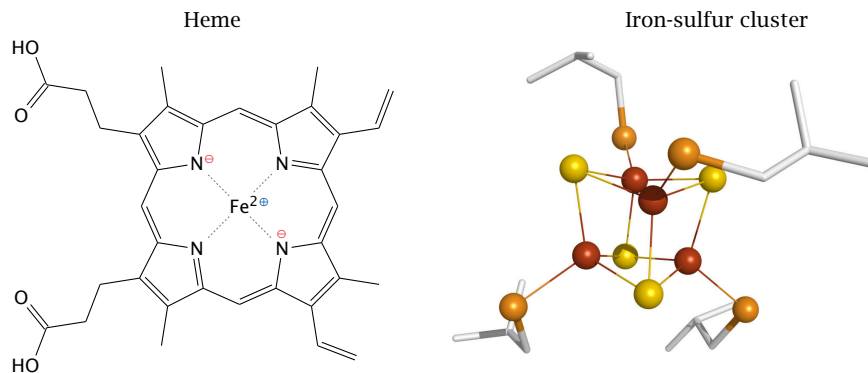

Notes: Most of the redox cofactors in the respiratory chain are hemes and iron-sulfur clusters, both of which contain iron ions. Hemes are tetrapyrrole rings that hold a single central iron ion. This iron ion can adopt different oxidation states, mostly Fe²⁺ and Fe³⁺, although Fe⁴⁺ occurs with one of the hemes in complex IV.⁷

In iron-sulfur clusters, it is again the iron that accepts and donates electrons by alternating between different oxidation states. Each iron ion is held in place by four sulfur atoms, which either belong to cysteine side chains (orange) or are free sulfides (S²⁻; yellow). The two types of sulfurs may occur in various proportions, which results in iron-sulfur clusters of different size.

The pyrrole rings or sulfur atoms do not only keep the iron ions in place but also modulate their redox potentials. These potentials are further tweaked by the specific molecular environment of each cofactor, in such a way as to enable the electrons to flow from one cofactor to the next.



6.2 Describe the iron-containing redox cofactors that occur in the respiratory chain.

6.4.2 Flavin-containing redox cofactors

Notes: The flavin nucleotides flavin adenine dinucleotide (FAD) and flavin mononucleotide (FMN) can occur in three different states of reduction, which differ by single electrons. Unlike NAD, which can accept or donate electrons only in pairs, flavins can accept or yield electrons one at a time. Therefore, flavins can buffer the electron flow between NAD and iron-containing redox cofactors, and this is

⁷Some of the hemes in the respiratory chain are referred to as “cytochromes.” Somewhat confusingly, the same term is, with other molecules, applied to the entire complex of a heme and the protein it is bound to.

why the very first cofactor that accepts the electrons from NADH in complex I is indeed an FMN molecule.⁸

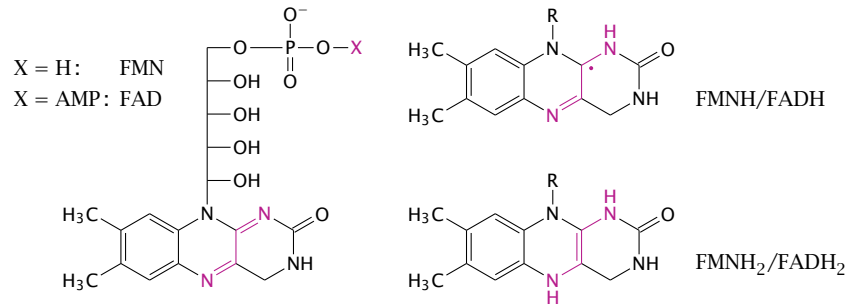

In addition to the stationary redox cofactors that occur within complexes I-IV, there are two electron carriers that are not tightly associated with one individual complex but function as shuttles between them:

1. Ubiquinone or coenzyme Q. This coenzyme contains a quinone group. It carries electrons, as hydrogen, from complexes I and II to complex III. It also contains a long hydrophobic polyisoprene tail, which confines it to the hydrophobic interior of the membrane. Like flavins, ubiquinone can transfer electrons singly or in pairs; this is important in the coenzyme Q cycle (see slide 6.6.3).

2. Cytochrome C. This is a small protein that again contains a heme. It is located at the outer surface of the inner mitochondrial membrane and shuttles electrons between complex III and complex IV.⁹



6.3 Explain the role of flavin cofactors in electron transfer processes.

6.4.3 The respiratory chain produces reactive oxygen species as byproducts

Notes: Several redox cofactors in the respiratory chain are prone to side reactions with molecular oxygen, which produce superoxide ($O_2^{\cdot -}$) and other *reactive oxygen species*, that is, partially reduced forms of oxygen. These have the potential to damage cellular membranes and macromolecules and must be scavenged. This topic is discussed further in slide 9.3.8.

⁸Electron buffering between NADPH and heme by flavins occurs in cytochrome P450 reductase (see slide 18.2) and in nitric oxide synthase (slide 9.3.5).

⁹In addition to its role in the respiratory chain, cytochrome C is also an important intracellular signaling molecule; its release from damaged mitochondria triggers apoptosis (programmed cell death; see reference [17] and slide 18.5.1). Another molecule with surprising connections to apoptosis is glyceraldehyde-3-phosphate dehydrogenase [18]; this enzyme is reportedly associated with the outer mitochondrial membrane.

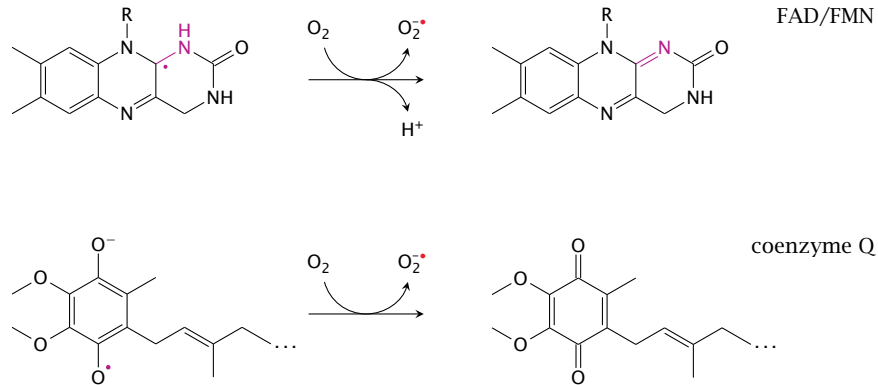

6.5 The energetics of electron transport

In discussing the driving forces of electron transport above, we have referred to both the free energy and the redox potential. Before considering the energetics of the respiratory chain in more detail, we will briefly review how exactly these two physical terms relate to one another.

6.5.1 Redox reactions can be compartmentalized to produce a measurable voltage

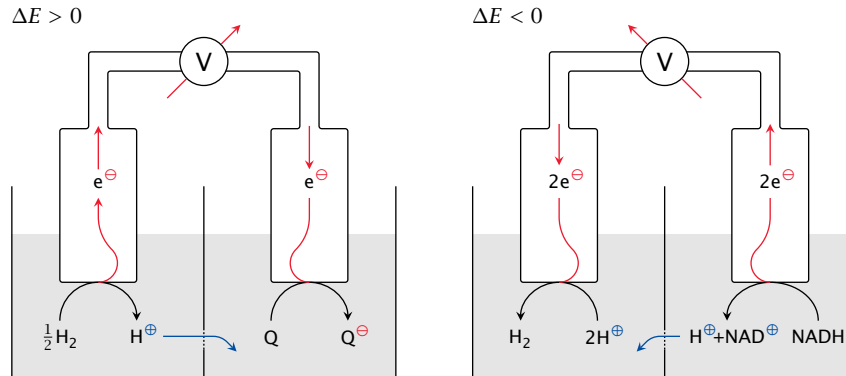

Notes: This slide illustrates the experimental setup for measuring the redox potential of an electron carrier. Left panel: coenzyme Q withdraws electrons from the standard hydrogen electrode, which by definition gives it a positive redox potential (ΔE). Right: NADH pushes electrons toward the standard electrode, making its ΔE negative.

In the experimental setup, the molecule of interest and a reference solute are contained in two adjacent buffer-filled chambers. Platinum electrodes are immersed in both solutions and connected through a voltmeter (V). As electrons are withdrawn from the solute in one chamber and delivered to the other, the voltmeter indicates the direction and magnitude of the potential difference. Protons and other ions can flow across a salt bridge between the chambers so as to preserve electroneutrality. In order to allow the flow of ions but prevent mixing of the

chamber contents by convection, this hole is covered with a porous membrane or plugged with agar.

The reference solute commonly used in chemistry is H_2 , equilibrated with hydrogen gas at 1 atm above the solution. The corresponding oxidized form, H^+ , is adjusted to 1 mol/l or pH 0. The immersed platinum electrode not only conducts electrons but also serves as a catalyst for the interconversion between H_2 and H^+ .

The potential of a redox carrier measured against this electrode is defined as its *standard redox potential* or ΔE_0 . For biochemical purposes, the standard electrode solution is buffered at pH 7 rather than pH 0, and the redox potentials measured against this electrode are referred to as $\Delta E'_0$. A pH of 7 is just as arbitrary a reference point as pH 0, but we will stick with it because the textbooks do so, too.

6.5.2 The redox potential (ΔE) is proportional to the free energy (ΔG)

$$\Delta G \equiv \frac{\text{energy}}{\text{moles (number of molecules)}}$$

$$\Delta E \equiv \frac{\text{energy}}{\text{charge transferred}}$$

$$\Delta G = \frac{\text{energy}}{\text{charge transferred}} \times \frac{\text{charge transferred}}{\text{moles}}$$

$$\Delta G = \Delta E \times \frac{\text{charge transferred}}{\text{moles}}$$

therefore

$$\Delta G = -\Delta E \times n \times F \quad (6.1)$$

Notes: From the previous slide, it is clear that electrons will flow spontaneously from one redox cofactor to another if the corresponding ΔE is positive. We also know that reactions proceed spontaneously if their ΔG is negative. The two parameters are directly related to one another according to equation 6.1. Either one is therefore sufficient to describe the energetics of the reaction; the reason why redox potentials are more commonly used in this context is that they can be measured more directly than ΔG .

In the equation, ΔE is the difference in the redox potentials between two cofactors. The parameter n is the number of electrons transferred in the reaction; for example, NADH feeds two electrons at a time into the chain, which means that n equals two for this reaction. In contrast, heme typically accepts and donates single electrons, which means that $n = 1$. The F in the equation is Faraday's constant, which tells us how many units of charge are carried by one mole elec-

trons (96,500 coulombs/mol).¹⁰ One can think of a cofactor's redox potential as its affinity for electrons—the higher it is, the more strongly the cofactor will attract electrons.¹¹

6.5.3 Redox potentials and free energies in the respiratory chain

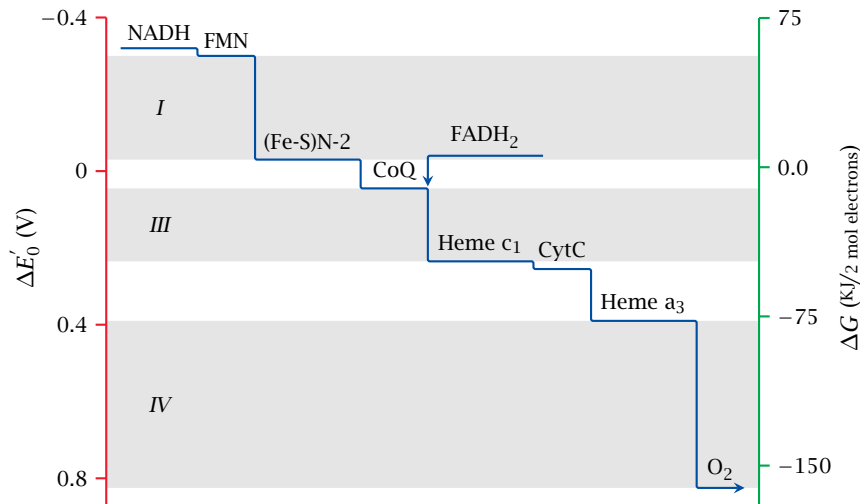

Notes: This slide shows the redox potentials, and the corresponding free energy levels, of some selected electron carriers in the respiratory chain. The lowest potential is found with NAD^+ , in keeping with its position at the start of the transport chain. The next carrier in sequence, FMN, is part of complex I. It has a slightly higher potential than NADH and is therefore able to accept its electrons. The redox potential increases continuously along the respiratory chain to reach its highest value at oxygen, which therefore has the highest affinity for the electrons and gets to keep them. Reduced oxygen, which recombines with protons to yield water, thus is the end product of respiration.

The iron-sulfur cluster N2, which occupies the lowermost position within complex I as shown in slide 6.4, has a significantly higher potential than the FMN. This step in potential corresponds to a significant amount of free energy that is released at some point within complex I as the electrons travel through it from FMN toward N2. Complex I uses this energy to expel protons from the mitochondrion, against

¹⁰Remember that the volt, which is the unit of ΔE , is defined as joule/coulomb , since voltage = energy/charge , hence the need for Faraday's constant.

Like Avogadro's number, Faraday's constant is a relic of history, required only because the physical units of mass and electrical charge had already been arbitrarily chosen before the inherent masses and charges of atoms and electrons were discovered. One could in principle define a system of units without either of these crummy numbers. Indeed, chemists often use Daltons, and physicists use electron volts (eV), in order to avoid them.

The minus sign in equation 6.1 results from the fact that the electron-donating electrode, the cathode, is considered negative. This is entirely arbitrary and meaningless, but it is also very handy as a trap in exam questions.

¹¹You have encountered the same concept with chemical elements as their *electronegativity*: An element with a high electronegativity holds on to electrons particularly tightly, i.e. it has a high affinity for electrons.

their concentration gradient. Major steps in potential that drive proton expulsion also occur within complex III and complex IV.

Only minor steps of potential occur in the delivery of electrons from complex I to complex III via coenzyme Q, and between complexes III and IV via cytochrome C. Likewise, with complex II, the potentials of both entry and exit points must fall into the narrow interval between FADH₂ and coenzyme Q, which means that very little energy is released as electrons traverse this complex. Such minor steps in redox potential suffice to jog the electrons along, but they are too small to contribute to proton pumping.



6.4 What is the relationship between free energy and redox potential?



6.5 At which of the four complexes in the electron transport chain does the greatest step in redox potential occur? Which one has the smallest step?

6.6 Interfacing different types of electron carriers

In addition to their specific redox potentials, which establish the general direction of electron flow, the redox cofactors in the respiratory chain also differ in two other important aspects:

1. NADH, FADH₂, FMNH₂ and coenzyme Q carry both electrons and protons—that is, hydrogen. In contrast, the hemes and the iron-sulfur clusters carry only electrons.
2. NAD⁺ can only accept and donate *pairs* of electrons, whereas the hemes and iron-sulfur clusters can only accept and donate *single* electrons.

The switch from the two-electron carrier NADH to the one-electron carrying Fe–S clusters within complex I is negotiated by FMN, which, as discussed above, can accept or donate electrons both pairwise and singly.

6.6.1 The first two redox steps in complex I

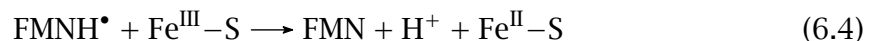
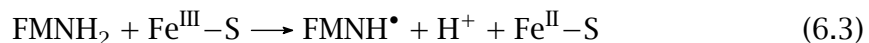
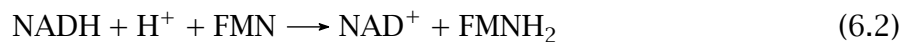

Notes: After accepting H₂ from NADH + H⁺ (equation 6.2), FMNH₂ donates the electrons one by one to the first Fe–S cluster (equations 6.3 and 6.4), adopting a sufficiently stable radical form between these two transfers. The electron transfer between FMNH₂ and Fe–S also illustrates what happens if an electron-only carrier is reduced by a hydrogen carrier: The protons are simply shed into the solution.



6.6 Explain how electrons are transferred from NADH to the iron-sulfur clusters in complex I.

6.6.2 The reduction of coenzyme Q involves protons and electrons

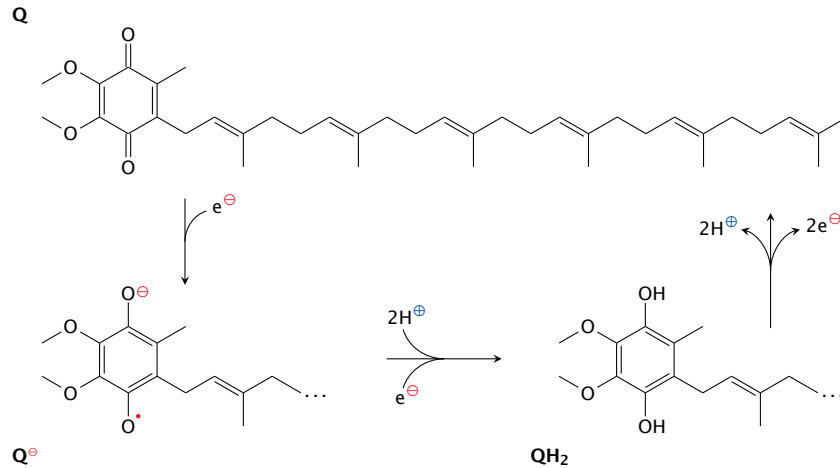

Notes: Hydrogen carriers may also be reduced by electron carriers. This happens with coenzyme Q, which is reduced by the iron sulfur cluster N2 in complex I. In this case, protons are taken up from the solution, but only in the second reduction step:

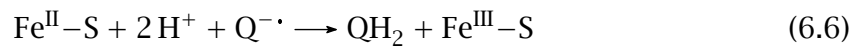
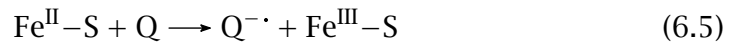

Hydrogen carriers alternate with electron-only carriers at several points in the chain. This means that electrons are stripped of their protons and rejoin by protons again repeatedly during transport. Where protons are stripped off, they may be preferentially released at the cytosolic side, whereas uptake of protons may preferentially occur on the mitochondrial side. This would account for some, but not all of the proton translocation occurring in the respiratory chain.

As an example of the foregoing, we will have a look at the (in)famous ubiquinone cycle. Ubiquinone (or coenzyme Q) is a hydrogen carrier; like FAD and FMN, it can carry two electrons but can accept and donate them one at a time.

6.6.3 The Q cycle (criminally simplified)

Notes: The Q cycle or ubiquinone cycle runs within complex III, which accepts reduced ubiquinone from the surrounding membrane. Complex III has two binding sites for ubiquinone, and both of them are occupied while the cycle runs; we will here call them A and B. The ubiquinone cycle goes through the following stages, starting at the top left:

1. At the outset, a reduced ubiquinone (QH_2) is bound to site A, and an oxidized one (Q) is bound to site B. The protons of QH_2 are stripped off and expelled to the cytosolic side. The electrons part company and migrate to two different

electron carrier groups within complex III; one of these is an iron-sulfur cluster, whereas the other is a heme.

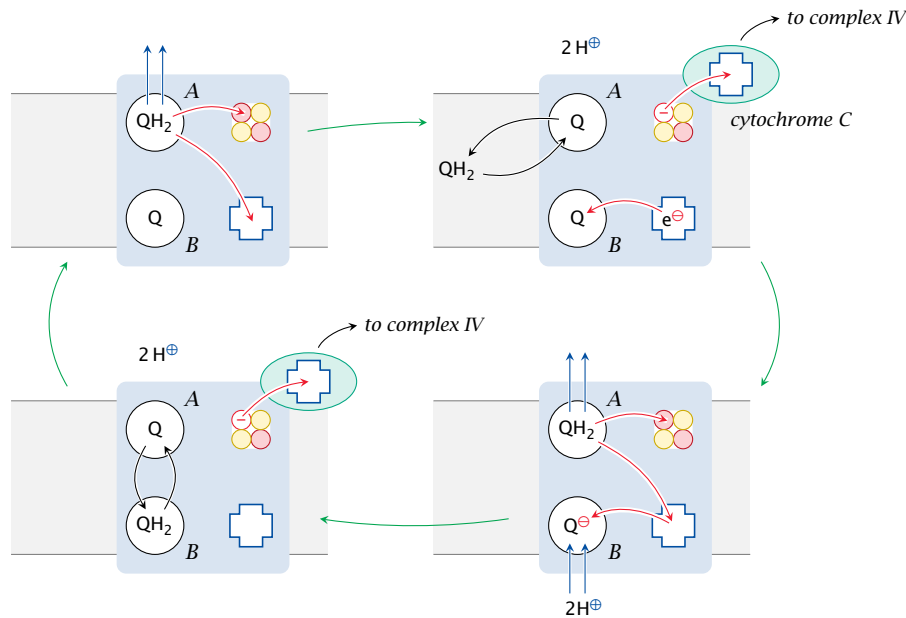

2. The iron sulfur cluster donates its electron to cytochrome C, while the heme transfers its electron to the second molecule of ubiquinone in site B. The ubiquinone molecule in site A, now oxidized, trades places with another one in the surrounding membrane that was reduced in the preceding steps of the respiratory chain.
3. The protons and electrons of the new QH_2 in site A are abstracted and split as in the first step. The heme passes on its electron to coenzyme Q in site B. Now completely reduced, the coenzyme Q picks up two protons from the mitochondrial matrix to form QH_2 .
4. The electron that had been transferred to the Fe-S cluster is donated to cytochrome C. The Q in site A trades places with QH_2 in site B, which completes the cycle.

According to this scheme, with each molecule of ubiquinone reduced in the respiratory chain, the two protons it carries are expelled into the cytosol, and two additional protons are taken up from the mitochondrial matrix and expelled into the cytosol as well. Therefore, complex III uses ubiquinone as a prosthetic group to facilitate the movement of protons across the membrane.

If you compare the outline of the ubiquinone cycle given here to the description in your textbook, you might find the similarity somewhat remote. In reality, as you can see in slide 6.4, complex III contains several more redox co-factors that act as intermediate stepping stones in the electron transfer steps outlined above. They have been skipped here for simplicity.



6.7 How can electrons be transferred from electron-only carriers such as iron-sulfur clusters to hydrogen carriers such as ubiquinone?

6.6.4 Reduction of oxygen by cytochrome C oxidase (complex IV)

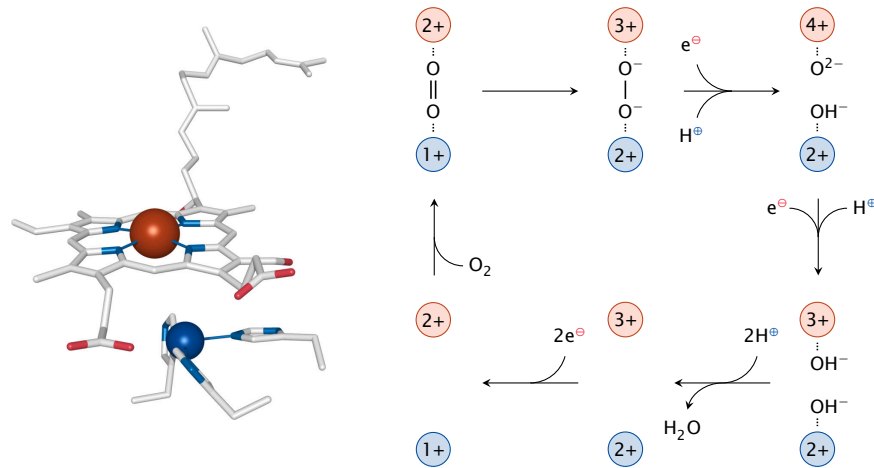

Notes: Cytochrome C is a small hemoprotein that shuttles electrons from complex III to complex IV. The latter complex, which is also known as cytochrome C oxidase, completes the transfer of electrons by delivering them to oxygen. In the process, it pumps some more protons out of the mitochondrial matrix. The reduction of oxygen is the trickiest step in the entire respiratory chain, as it takes a full four electrons to reduce molecular oxygen (O₂) all the way to two molecules of water. Since cytochrome C delivers the electrons to complex IV one at a time, the reduction will involve partially reduced oxygen species. As noted above, partially reduced oxygen species are reactive and toxic when let loose upon the cell, so their premature release from cytochrome C oxidase must be minimized.

Cytochrome C oxidase does its best to control this problem by binding oxygen tightly and reducing it swiftly. The oxygen molecule is clamped in the active site between the iron of a heme and a copper ion, which is coordinated by three histidine residues (left). Both metal ions also function as redox cofactors in the reduction. Each of them advances one electron to the oxygen, which is thereby reduced to peroxide, using one electron from each metal ion. Uptake of an electron delivered by cytochrome C and abstraction of a further one from the iron fully reduces both oxygen atoms. Uptake of protons generates first hydroxide and then water, which is released. Iron and copper are subsequently restored to their original oxidation levels further electrons obtained from cytochrome C.



6.8 Explain how cytochrome C oxidase (complex IV) minimizes the formation of reactive oxygen species in the stepwise reduction of oxygen.

6.7 How is electron transport linked to proton pumping?

- Some redox steps in the ETC are coupled to proton binding and dissociation, which may occur at opposite sides of the membrane. Example: Coenzyme Q cycle at complex III

- Redox steps that do not involve hydrogen directly need a different mechanism in order to contribute to proton pumping. Example: Sequence of iron-sulfur clusters and hemes in complex IV

Notes: As pointed out above, some of the protons that undergo expulsion from the mitochondrion are accepted from the hydrogen carriers NADH and ubiquinone and travel together with electrons for a part of the journey. However, at some point they must part company, and the protons must be expelled, whereas the electrons are retained. Also, more protons are being expelled than can be accounted for by the hydrogen carriers. This is obvious with complex IV, which does not interact with any hydrogen carriers at all yet expels up to four protons for each pair of electrons accepted. So, there must be mechanisms that extract energy from the transfer of proton-less electrons and apply it towards the expulsion of electron-less protons. How does this work?

6.7.1 Linking electron movement to proton pumping: A conceptual model

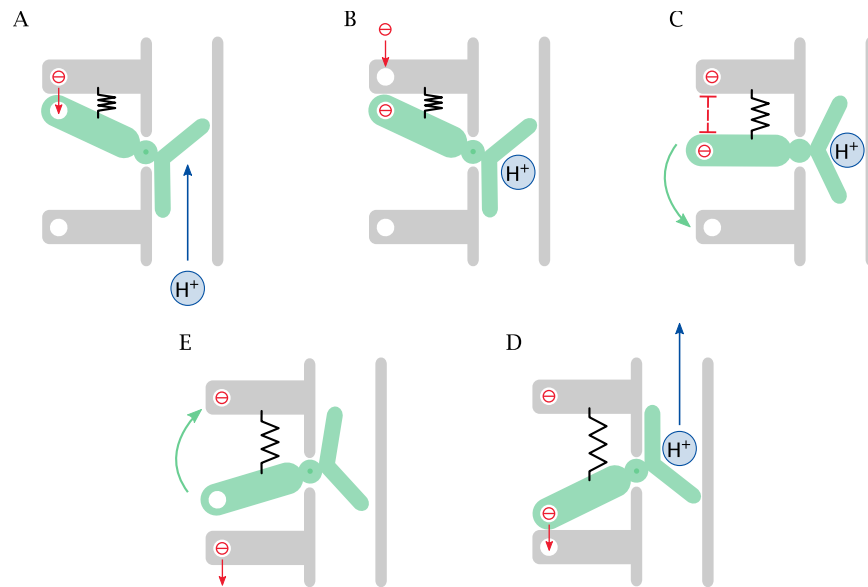

Notes: The experimental evidence on this point is still fragmentary, and inasmuch as they are understood, the emerging mechanisms are quite complex. Therefore, instead of trying to describe them faithfully, this slide presents a simplified conceptual model to provide an idea of how things might work.

The basic idea is that capture and release of electrons cause conformational changes to a protein. This is entirely analogous to conformational changes caused by allosteric effectors binding to enzymes, or by phosphate groups bound to cytoskeletal proteins such as the myosin light chain. An electron carries a charge, a charge causes a field, and a field creates forces that act on charged residues on the protein; thus, in principle, it is not hard to imagine how migrating electrons can cause conformational changes.

In our conceptual model, a spring-loaded valve controls the proton conduit. The lever of the valve carries an electron-transporting cofactor (a heme or FeS-cluster). This cofactor receives an electron from another cofactor upstream (A), which then becomes occupied by the next electron (B). Electrostatic repulsion moves the valve (C), such that the proton is translocated and the electron can jump to the next cofactor downstream (D). The extended spring—which is a metaphor for conformational strain—then returns the valve to its original position (E).

6.7.2 Stoichiometry of proton ejection

It is commonly stated that approximately ten protons are ejected for each pair of electrons abstracted from NADH, such that four protons are ejected at each of complexes I and IV, and 2 at complex III.¹² Complex II does not eject any protons but just abstracts them from FADH₂ and passes them on to ubiquinone. If you look at slide 6.5.3, you will notice that the difference in the redox potentials of FAD and ubiquinone is rather small. Consequently, the amount of free energy associated with the transfer of electrons from FAD to ubiquinone is too small to permit the performance of work against the proton gradient.

6.8 ATP synthesis

Most of the ATP that results from complete oxidative degradation of glucose is synthesized only after the substrate has already vanished in the form of CO₂ and H₂O. At this stage, the entire available energy is stored in the so-called proton-motive force across the inner mitochondrial membrane. ATP synthesis is powered by the protons that yield to this force and are pulled back by it into the mitochondrion.

6.8.1 Proton pumping creates both a concentration gradient and a membrane potential

Notes: The proton concentration in the cytosol is approximately ten times higher than that in the mitochondrial matrix. While this creates a significant driving force, the larger contribution to the overall proton-motive force comes from the electrostatic membrane potential across the inner mitochondrial membrane. Like the proton concentration gradient, this electrical potential is a direct consequence of the proton pumping: Each proton ejected leaves one negative charge behind inside the mitochondrion.

In a fully energized mitochondrion, the membrane potential amounts to approximately ~150 mV.¹³ According to equation 6.8, this potential confers a free energy of approximately 15 kJ/mol to each proton, whereas equation 6.7 indicates a

¹²Note that this number is at variance with the mechanism of the coenzyme Q cycle given above, which ejects four protons for each equivalent of ubiquinone. Different sources offer varying numbers.

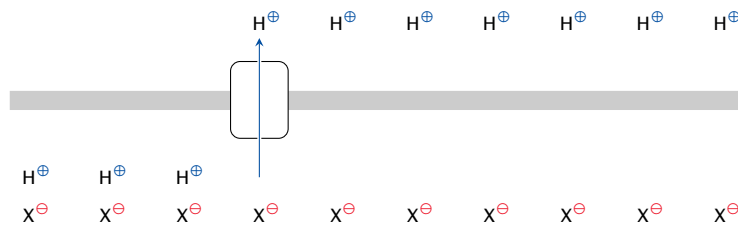

¹³Above a potential of 150 mV, the inner membrane becomes increasingly leaky for protons (see section 6.10), so that such higher potentials will not be sustained.

contribution of only 6 kJ/mol from the concentration gradient. In summary, therefore, the proton-motive force is dominated by the membrane potential.



$$\Delta G_{\text{concentration}} = RT \ln \frac{[\text{H}^+]_{\text{in}}}{[\text{H}^+]_{\text{out}}} = 6 \frac{\text{kJ}}{\text{mol}} \quad (6.7)$$

$$\Delta G_{\text{potential}} = \Delta\psi \times n \times F = 15 \frac{\text{kJ}}{\text{mol}} \quad (6.8)$$

-  **6.9** What are the two physical forces that together form the “proton-motive force” at the inner mitochondrial membrane, and which is the dominant one?
-  **6.10** Compare the proton-motive force of ~ 20 kJ/mol to the free energies of electron transport at each respiratory chain complex in slide 6.5.2. What conclusions can you draw for the plausible stoichiometry of proton ejection at each complex?

6.8.2 Structure of ATP synthase

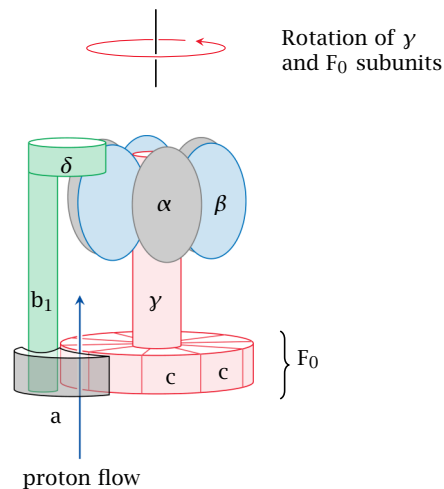

Notes: This complex and fascinating molecule is both an enzyme and a molecular motor.¹⁴ The slide shows a side view. Ten identical *c* subunits are arranged like pie slices; the whole cylindrical pie is referred to as the F_0 subunit. It and the *a* subunit are embedded in the inner mitochondrial membrane, whereas the other subunits of the molecule protrude into the mitochondrial matrix.

¹⁴A similar molecular motor drives the rotation of the flagella found in many bacteria, which enables them to swim. Remember that mitochondria are of bacterial origin.

The F_0 and the γ subunit (both shaded in red) rotate relative to all other subunits. The γ stalk therefore rotates within and rubs against the bushing formed by the six α and β subunits. The rotation is driven by the flow of protons that occurs at the interface of the a and F_0 subunits.

6.8.3 The binding-change model of ATP synthase catalysis

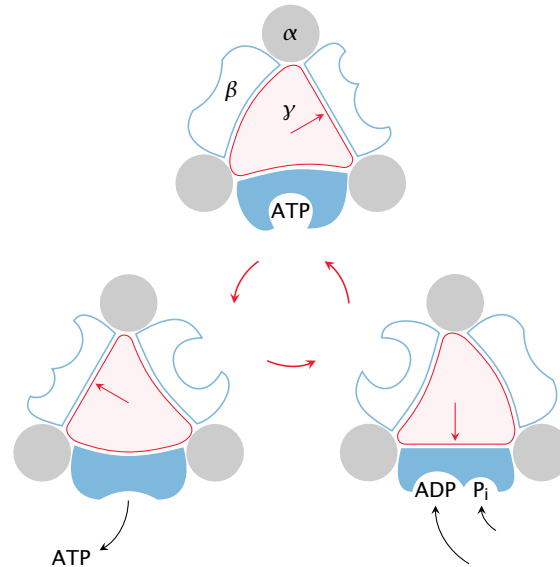

Notes: The interaction of the rotating γ subunit with the static β subunits is crucial to ATP synthesis. Because of the asymmetric shape of the γ subunit, its rotation imposes cyclic conformational changes upon the α and β subunits that surround it. The β subunit, which contains the active site of the enzyme, extracts mechanical work from these conformational changes and ultimately converts it into the chemical energy contained in ATP.

How does the β subunit convert mechanical into chemical energy? Strictly speaking, it doesn't—it turns out that the isolated β -subunit can create ATP from ADP and ionic phosphate all by itself. In doing so, the β subunit adopts two distinct conformational states. In the first state, it binds ADP and phosphate. Once both are bound, β transitions to the second state, which binds ATP with exceptionally high affinity but no longer binds ADP and phosphate. Formation of several avid but non-covalent bonds between β and ATP provides the energy that is needed to create the new, energy-rich phosphate anhydride bond in ATP.

With the isolated β subunit, we have at this point reached a dead end—ATP is bound so avidly as to never be released, which means that no further turnover can occur. It is at this stage that, in the intact enzyme, the γ subunit comes into play. Rotation of γ forces another change of conformation upon β that in turn kicks the ATP out of the active site. The force imposed by γ on β must be so strong as to overcome and offset the large binding energy that ties the ATP to β . In summary, therefore, the synthesis of ATP proceeds spontaneously inside β , and the energy

of rotation is applied to force out the avidly bound ATP and prime β for the *next* round of catalysis.



6.11 Explain the binding-change model of ATP synthesis inside ATP synthase.

6.8.4 How does proton flux drive ATP synthase?

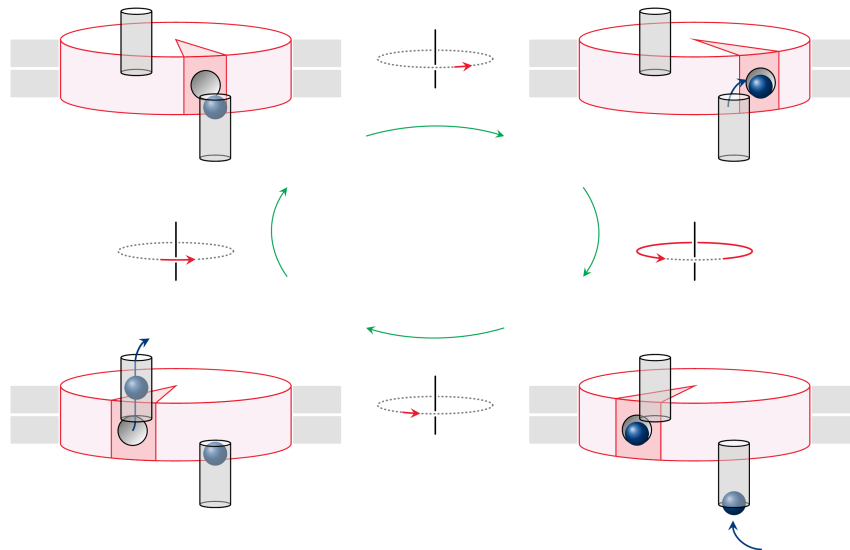

Notes: The last remaining puzzle is how the proton flux actually causes the moving parts of the enzyme to rotate. As shown in slide 6.8.2, the proton flux passes between the a subunit and the F_0 subunit, which contains 10 identical c chains arranged in a pie-slice fashion; for simplicity, only one c chain is highlighted in the current slide.

The two gray cylinders in this cartoon are proton conduits contained within the a subunit; the remainder of the a subunit is not shown. The proton conduits span the outer and the inner membrane leaflet, respectively, but they do not meet; it is the rotating F_0 disk that mediates the flow of protons between them. To this end, each c chain has a strategic aspartate residue that faces the surrounding lipid membrane and can reversibly accept a proton.

In the top left of the figure, the aspartate (shown as a little groove) of the highlighted c subunit is about to accept a proton from the periplasmic space¹⁵ via the corresponding conduit. In the next frame, the disk has moved a bit and accepted the proton; it then goes around by almost a full turn, until it reaches the other conduit (bottom right). In the final frame, the proton has left the disk and is on its way to the mitochondrial matrix, while the c subunit is about to move on and pick up then next proton.

There is indeed evidence that agrees with this model; for example, the strategic aspartate on the F_0 disk is alternately accessible from the two opposite sides of the membrane. However, while it seems simple and elegant, this model has

¹⁵The periplasmic space is the narrow space between the inner and the outer mitochondrial membrane.

one fundamental shortcoming: While it tells us how rotation of ATP synthase can dissipate the proton gradient, it does not explain how ATP synthase manages to derive any torque from this process, so that it can perform work against resistance. More specifically, what makes the rotor keep going in the same direction instead of just oscillating back and forth between the two conduits? This would save it the trouble of performing work, while still permitting proton flux.¹⁶

6.8.5 Proton flux causes c chains to rotate *within* the F_0 disk

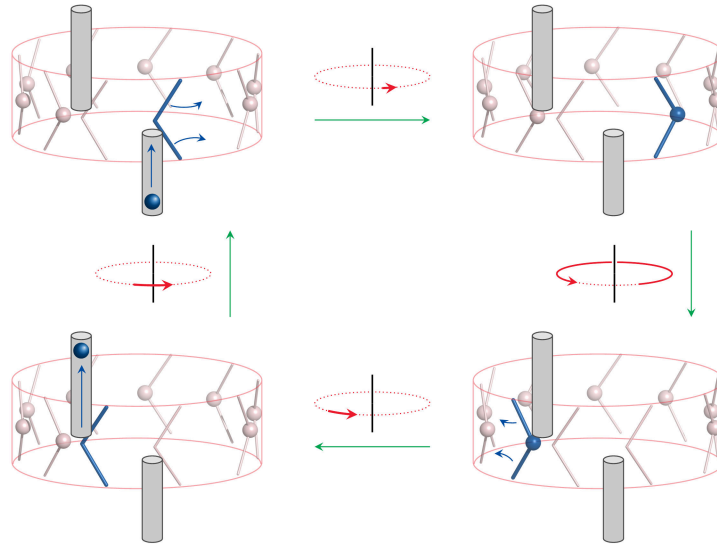

Notes: The absence of a flywheel effect that would help F_0 move past dead spots means that proton flux and F_0 rotation must be tightly coupled. This assumption is supported by the observation that the c chain undergoes a significant conformational change upon protonation or deprotonation [19]. The authors of the cited study proposed a functional model that is shown here in a simplified cartoon depiction.

One of the 10 c subunits is highlighted in blue, as is the proton carried by it. In the top left, this subunit is about to accept a proton from the cytosolic conduit. In the second frame, the proton has been accepted, and the c subunit has rotated about its own axis. The entire F_0 disk then rotates by nearly a full turn, which brings our highlighted c subunit to the inward-connecting conduit. The aspartate now delivers its proton, whereupon the subunit swivels back about its own axis. During this transition, the aspartate holds on to the end of the conduit—that is, the stationary a subunit—and thus causes the entire F_0 disk to rotate forward. This second rotation of the c subunit constitutes the “power stroke” of the engine.

The model implies that the number of protons transported per rotation is identical to that of the c subunits in F_0 . Intriguingly, ATP synthases in different

¹⁶A steam engine gets around a similar problem by employing inertia, which is provided by a nice, heavy, cast-iron flywheel. That is not possible here because of the minuscule dimensions. A student who took my class in 2005, Kelvin Cheung, took on the challenge to calculate the kinetic energy of rotating ATP synthase; it works out to about *one billionth* of the energy required for making 1 ATP.

organisms vary in their number of c subunits, which will directly affect the stoichiometric ratio of ATP synthesis to proton transport. It would be interesting to know whether there are complementary variations in the number of protons driven out per electron during electron transport. Otherwise, the different subunit stoichiometry of F_0 should directly translate into a different ATP yield in the entire respiratory chain.

6.9 Auxiliary shuttles for the mitochondrial reoxidation of cytosolic NADH

In slide 3.4.1, it was mentioned that, under aerobic conditions, the NAD^+ converted to NADH in the cytosol by glyceraldehyde-3-phosphate dehydrogenase is re-oxidized in the respiratory chain. NADH itself, however, cannot pass the inner mitochondrial membrane, and in fact not even the more permissive outer membrane. How, then, is its oxidation accomplished?

It turns out that NADH is not translocated at all but is reoxidized, or dehydrogenated, in the cytosol. The hydrogen is then taken to the mitochondrion by other carriers. These shuttle systems work in a somewhat roundabout manner, tying together several enzyme activities with specific transporters in the inner mitochondrial membrane.

6.9.1 A hypothetical malate-oxaloacetate shuttle

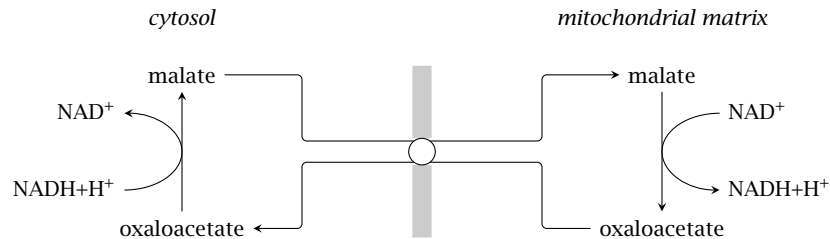

Notes: A simple but somewhat dubious shuttle is shown in this picture. Among the various mitochondrial exchange transporters that engage malate, there is one that can directly swap it for oxaloacetate [20]. This transporter has been found in the mitochondria of multiple mammalian organs, and under suitable conditions *in vitro*, it can sustain reoxidation of external NADH by isolated mitochondria [21].

The problem with this hypothetical shuttle is the ratio of NADH to NAD^+ , which *in vivo* is usually higher in the mitochondria than in the cytosol. This should crank the malate-oxaloacetate shuttle the wrong way, exporting NADH from the mitochondria rather than importing it. Therefore, until evidence of its operation within intact cells becomes available, this cycle cannot be assumed to be of major significance.

6.9.2 The malate-aspartate shuttle

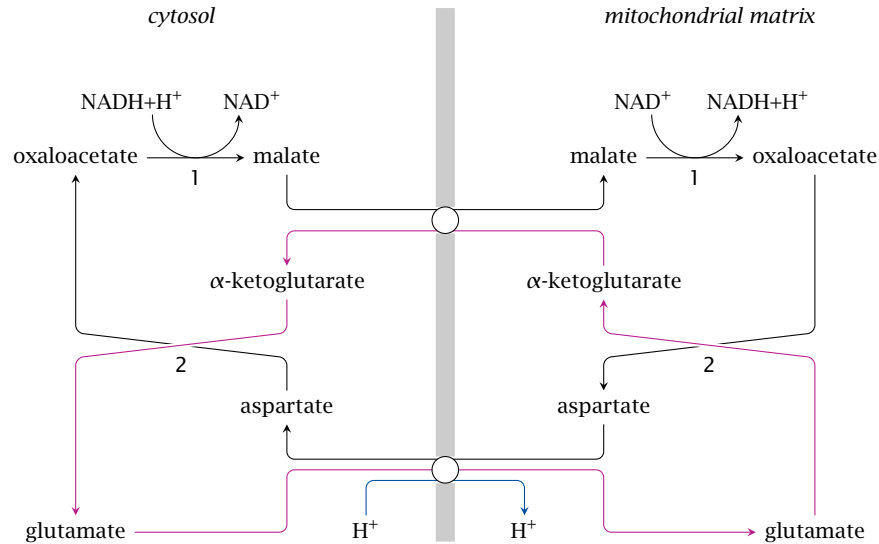

Notes: The malate-aspartate shuttle combines four substrates and two transporters with two enzymes, both of which are required on both sides of the membrane. In the cytosol, malate dehydrogenase (1) regenerates NAD^+ by reducing oxaloacetate to malate, which is then exchanged for mitochondrial α -ketoglutarate. Inside the mitochondrion, malate is converted back to oxaloacetate, which is then transaminated by aspartate aminotransferase (2). This yields aspartate, which is exchanged for cytosolic glutamate, as well as α -ketoglutarate, which is exchanged for malate. Transamination is then reversed in the cytosol, which restores oxaloacetate and glutamate and closes the cycle.

While the malate-aspartate shuttle is more complex than the malate-oxaloacetate shuttle, it does have the advantage with respect to driving force: the glutamate-aspartate exchanger cotransports one proton with each molecule of glutamate, which means that the proton-motive force drives the cycle in the required direction [22].

The significance of this shuttle *in vivo* is supported by both experimental and clinical observations. Genetic defects of enzymes or carriers in the cycle cause *lactic acidosis*, that is, a pathological accumulation of lactic acid in the body, which indicates that the normal disposal of cytosolic NADH is disrupted. Similarly, pharmacological inhibition of aspartate aminotransferase with aminoxyacetate inhibits glucose oxidation and increases lactate levels [22, 23].



6.12 Draw the malate-aspartate shuttle, and explain why it is more plausible to occur *in vivo* than the simpler, hypothetical direct exchange of malate and oxaloacetate.

6.9.3 The glycerophosphate shuttle

Notes: In the glycerophosphate shuttle, the hydrogen is never actually transported to the mitochondrion. Dihydroxyacetone phosphate serves as the intermediate

hydrogen acceptor and is reduced in the cytosol to glycerophosphate by glycerophosphate dehydrogenase. Glycerophosphate traverses the outer mitochondrial membrane and is then reoxidized to dihydroxyacetone phosphate by a second glycerophosphate dehydrogenase (GPD). This enzyme is associated with the outer surface of the inner membrane, and it feeds the abstracted electrons directly into the respiratory chain at the level of coenzyme Q. Like succinate dehydrogenase, which also supplies electrons to the respiratory chain at the level of coenzyme Q, glycerophosphate dehydrogenase employs FAD as the coenzyme.

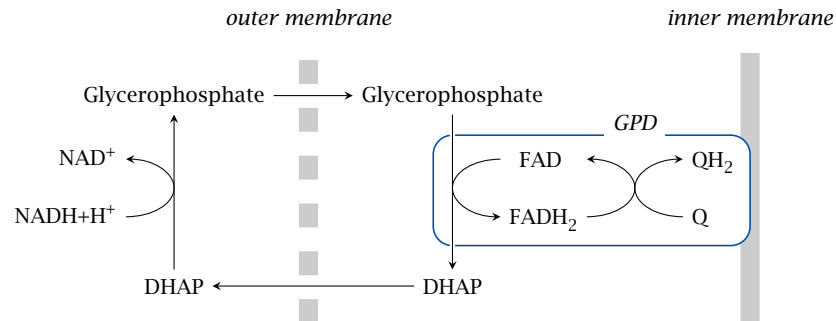

The glycerophosphate shuttle bypasses complex I in the respiratory chain and therefore induces ejection of four fewer protons from the cytosol. However, this shortfall is partially compensated for by the two protons that stay behind in the cytosol (or more accurately, the periplasmic space) when the electrons get abstracted from glycerophosphate. While slightly less energy-efficient than the malate-aspartate shuttle, this shuttle is certainly more straightforward, since it avoids all substrate transport across the inner mitochondrial membrane. In particular, it cuts out oxaloacetate, whose low concentration inside the mitochondrion probably forms the kinetic bottleneck of the malate-aspartate shuttle. It is interesting to note that the glycerophosphate shuttle is highly active in insect muscle, which has an extremely high ATP turnover during flight.



6.13 Explain the glycerophosphate shuttle and compare it to the malate-aspartate shuttle.

6.10 Regulation of the respiratory chain

Most of the time and in most cells, the respiratory chain runs at rates that are substantially below the maximum. How is the flow rate of the respiratory chain controlled? In a healthy and not maximally exerted cell, there is much more ATP than ADP or phosphate, so that these become limiting for the flow. If ATP synthase is short of substrates, dissipation of the proton-motive force will slow down. The proton pumps will find it difficult to extrude more protons, and since electron transport and proton pumping are tied to one another, the dehydrogenation of NADH and FADH_2 will slow down as well.

The flow rate of the respiratory chain also affects those of glycolysis and the TCA cycle. Both ATP and NADH participate in this regulation:

1. A low consumption of ATP will result in its accumulation to higher levels. Many enzymes, including phosphofructokinase, are inhibited by ATP.
2. Low activity of the respiratory chain causes NADH to accumulate, which slows down glyceraldehyde-3-phosphate dehydrogenase, pyruvate dehydrogenase, α -ketoglutarate dehydrogenase, and the NAD⁺-dependent isocitrate dehydrogenase.

It should be noted that mitochondrial respiration does not completely stall, even when no ADP is available as a substrate for ATP synthase. In this situation, the membrane potential across the inner mitochondrial membrane rises higher, which in turn makes the inner mitochondrial membrane more permeable to protons. This so-called *proton leak* is responsible for about 20% of the metabolic rate at rest. While several different transport proteins have been proposed to account for the proton leak [24], the most plausible mechanism is the futile cycle discussed in slide 6.10.3 below.

6.10.1 The two mitochondrial isocitrate dehydrogenases

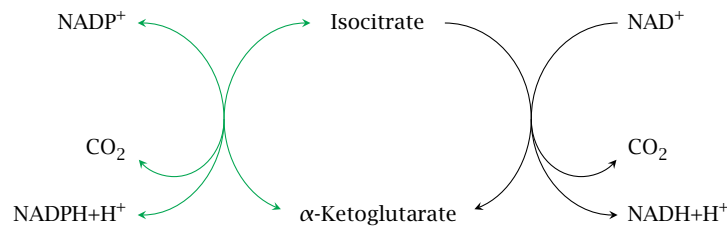

Notes: The above regulatory mechanisms are quite straightforward. There is, however, one remaining mystery. We have already noted that there are two forms of isocitrate dehydrogenase, one using NAD⁺ and the other NADP⁺ as the cosubstrate. While the NAD⁺-dependent form is inhibited by NADH and ATP, the NADP⁺-dependent form is not, and one might thus expect that it would go at full blast even when the demand for ATP is low and NADH is high. What is more, the NADP⁺-dependent enzyme is actually more highly expressed than the NAD⁺-dependent form. How, then, is the NADP⁺-dependent enzyme prevented from uncontrolled consumption of isocitrate, and why does it exist at all?

The answer to the first question is that, at least when demand for ATP is low, the NADP⁺-dependent isocitrate dehydrogenase reaction is close to equilibrium. This equilibrium is sustained by a high mitochondrial level of NADPH, which in turn is maintained by *nicotinamide nucleotide transhydrogenase*.

6.10.2 Nicotinamide nucleotide transhydrogenase couples hydrogen transfer with proton transport

Notes: This remarkable protein, which is located in the inner mitochondrial membrane, is both an enzyme and a transporter. It reduces NADP⁺ to NADPH at the

expense of NADH. As with ATP synthase, the enzyme reaction is coupled to the translocation of protons:

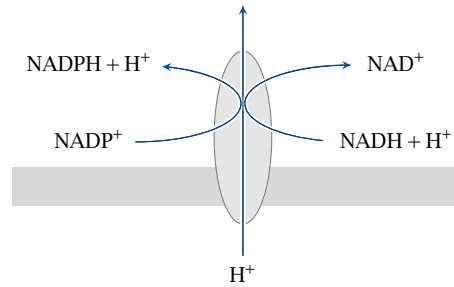
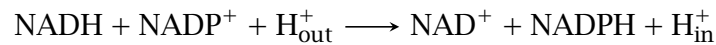

Note that the transhydrogenase involves only mitochondrial NAD and NADP; the pools existing in the cytosol are unaffected.

6.10.3 At rest, transhydrogenase and the isocitrate dehydrogenases form a futile cycle

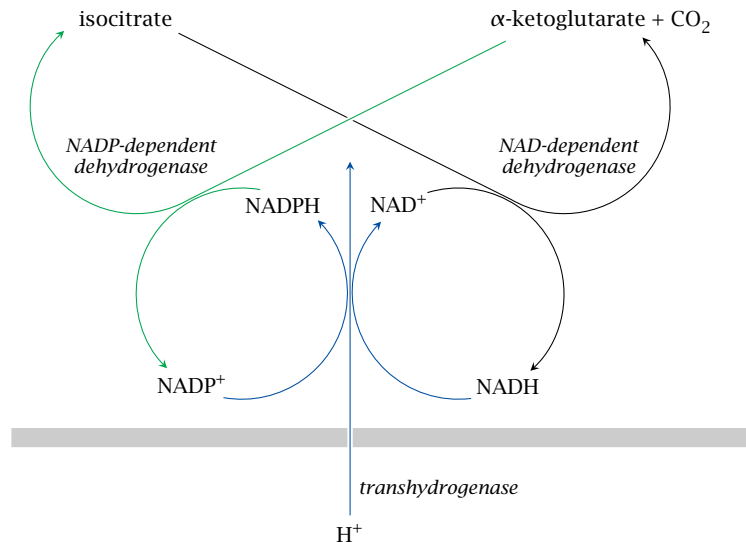

Notes: This slide and the following one show how the transhydrogenase may be integrated with the function and regulation of the TCA cycle and the respiratory chain [25].

When the demand for ATP is low, mitochondrial NADH and the proton-motive force will both be at high levels, which will cause the transhydrogenase to reduce NADP^+ at the expense of NADH. Accordingly, the NADPH concentration will be high, which results in near-equilibrium conditions for the NADP^+ -dependent isocitrate dehydrogenase also. If the NADPH concentration is high enough, there would be a low net flux within an interesting futile cycle that involves both isocitrate de-

hydrogenases and the transhydrogenase, and the net effect of which is the influx of one proton in each round.¹⁷

6.10.4 When ATP demand is high, transhydrogenase turns into an auxiliary proton pump

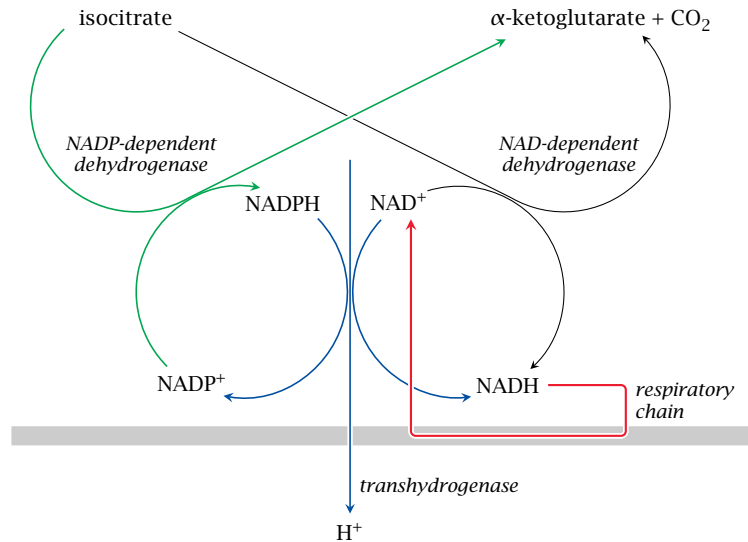

Notes: On the other hand, when the demand for ATP is high, the proton-motive force and the level of NADH will be lower. Under these conditions, the transhydrogenase should switch direction, now consuming NADPH to produce more NADH, which in turn will be consumed at a fast clip in the respiratory chain. This also means that transhydrogenase will work as an auxiliary proton pump, thus augmenting the proton-motive force and ATP synthesis.

What is more, the consumption of NADPH by transhydrogenase will topple the equilibrium of NADP^+ -dependent isocitrate dehydrogenase. Like the NAD^+ -dependent enzyme, it will now consume isocitrate. Due to the NADP^+ -dependent enzyme's higher abundance, NADPH will be preferentially generated, with the benefit of an extra proton expelled by transhydrogenase.

Now this is a truly marvelous piece of engineering by Mother Nature, isn't it? I'd say this is as close as it gets to intelligent design.



6.14 Is nicotinamide transhydrogenase proof of Life's creation by intelligent design?

6.11 ATP yield of complete glucose oxidation

The amount of ATP gained in the respiratory chain for each molecule of glucose degraded is large, but it cannot be calculated with complete precision and varies between different physiological states.

¹⁷This futile cycle might also contribute significantly to the proton leak that occurs at high levels of the proton-motive force (see section 6.10 above).

6.11.1 Theoretical ATP per molecule of glucose completely oxidized

Quantity	Intrinsic value	Per glucose
Accrued hydrogen		10 NADH, 2 FADH ₂
Protons ejected	10 per NADH, 6 per FADH ₂	112
Proton-powered ATP synthase revolutions	10 protons per revolution	11.2
ATP from ATP synthase	3 per revolution	33.6
ATP from glycolysis		2
GTP from TCA cycle		2
Total		37.6

Notes: The number of NADH molecules given here includes all molecules accruing in glycolysis, pyruvate dehydrogenase, and the TCA cycle. The numbers of protons pumped per molecule of NADH or FADH₂ are based on the assumption that complexes I, III, and IV pump 4, 2, and 4 protons, respectively. GTP, which is formed in the succinate thiokinase reaction in the TCA cycle, is energetically equivalent to ATP.

6.11.2 Processes other than ATP synthesis that are powered by the proton gradient

- Nicotinamide nucleotide transhydrogenase
- Uncoupling proteins; proton leak
- Secondary active transport:
 - ATP⁴⁻/ADP³⁻ antiport
 - phosphate/H⁺ symport
 - amino acid/H⁺ symport
 - pyruvate/H⁺ symport

Notes: The amount of ATP given in the preceding slide is a theoretical maximum. In reality, the ATP yield will be significantly lower, because some protons are used for purposes other than driving ATP synthase. Most importantly, some protons are needed for ATP transport. ATP synthesized in the mitochondrion must be exported to the cytosol, and ADP produced there has to get back in. This is accomplished by a special transporter protein in the inner mitochondrial membrane that exchanges ATP and ADP for each other. Since ATP carries one more negative charge than ADP (ATP⁴⁻ vs. ADP³⁻), this exchange amounts to a net export of one negative charge, or to the net import of one positive charge per ATP. Moreover, ionic phosphate produced by cytosolic ATP cleavage also must return

to the mitochondrion, which consumes another proton. These processes detract considerably from the theoretical efficiency of ATP synthesis.

The expenditure of extra protons on the transport of ATP, ADP and phosphate provides a clear benefit to the cell. It allows the transport of ATP and ADP against their concentration gradients. This enables the cell to maintain a high ATP/ADP ratio in the cytosol, which helps drive the ATP-consuming reactions there forward, whereas a higher ADP/ATP ratio in the mitochondria allows the ATP synthase to go at speed.

6.12 Answers to practice questions

6.1: The two experiments show that electron transport and proton pumping on the one hand, and ATP synthesis on the other, are functionally linked only by the proton gradient; there is no direct functional link between the proteins that carry out the two processes.

6.2: The iron-containing cofactors comprise hemes, which contain one iron ion coordinated in the center of a tetrapyrrol ring, and iron-sulfur clusters, which contain multiple iron ions bound by cysteine side chain thiol groups and free sulfide ions.

6.3: Flavin cofactors (FAD and FMN) are able to accept and donate electrons both singly and pairwise. They therefore mediate electron transfer between the nicotinamide cofactors (NADH and NADPH) and iron cofactors, which can only accept electrons one at a time.

6.4: $\Delta G = -\Delta E \times n \times F$. Therefore, reactions that are associated with a positive redox potential are exergonic and proceed spontaneously.

6.5: Largest: Complex IV; smallest: complex II.

6.6: NADH yields H_2 to FMN, which then yields the electrons in two discrete steps to the neighboring Fe-S cluster. Concomitantly, the protons are shed into solution.

6.7: Simultaneously with accepting electrons, the hydrogen carrier must pick up protons from solution.

6.8: The enzyme clamps O_2 between an iron and a copper ion, which between them advance three electrons to the oxygen molecule. Thus, a single electron arriving from upstream (cytochrome C) will suffice to complete the reduction, and the partially reduced state is of short duration.

6.9: The membrane potential is the dominant force, and the proton gradient is the minor one.

6.10: Complexes I, III and IV extract approximately 60, 40, and 80 kJ/mol, respectively, from electron transport. This would suggest that they expel no more than 3, 2, and 4 protons, respectively, from the mitochondrial matrix.

6.11: The catalytic β subunit has built-in ATP synthase activity; it can form ATP from free ADP and ionic phosphate, driven by its exceptionally high affinity for ATP. The ATP is ejected when the rotating γ subunit imposes a conformational change on the β subunit.

6.12: For the sketch, see slide 6.9.2. It is more plausible than direct malate-oxaloacetate exchange because it ties in the glutamate-aspartate exchanger, which is propelled in the desired direction by proton cotransport.

6.13: In the glycerophosphate shuttle, dihydroxyacetonephosphate in the cytosol accepts H_2 from NADH, enters the inter-membrane space, and is reoxidized by a cognate dehydrogenase that feeds the electrons into the respiratory chain at the level of coenzyme Q.

The electrons bypass complex I, which means that fewer protons are extruded from the mitochondrion compared to electrons that enter the mitochondria via the malate-aspartate shuttle. However, the glycerophosphate shuttle is simpler and probably has higher capacity than the malate-aspartate shuttle.

6.14: Almost.

Chapter 7

Gluconeogenesis

7.1 Introduction

Glucose is a key metabolite in human metabolism, but it is not always available at sufficient levels in the diet. Therefore, a pathway exists that converts other foodstuffs into glucose. This pathway is called gluconeogenesis.

7.1.1 Glucose is an indispensable metabolite

- The brain requires at least ~50% of its calories in the form of glucose
- Red blood cells exclusively subsist on glucose
- Glucose is a precursor of other sugars needed in the biosynthesis of nucleotides, glycoproteins, and glycolipids
- Glucose is needed to replenish NADPH, which supplies reducing power for biosynthesis and detoxification

Notes: These considerations make the need for gluconeogenesis quite clear—we can't just leave the blood glucose level up to the vagaries of dietary supply.

7.1.2 Overview of gluconeogenesis

Notes: Gluconeogenesis is the reversal of glycolysis, with several workarounds for the irreversible reactions in that pathway. In this scheme, the reactions that are shared between glycolysis and gluconeogenesis are shown in blue, whereas reactions that are specific for gluconeogenesis are shown in red. As you can see, both pyruvate and oxaloacetate are starting points for red arrows; therefore, any pathway that yields either of these, or indeed any other intermediate of glycolysis, can supply substrate carbon for gluconeogenesis. These pathways are indicated here by green arrows.

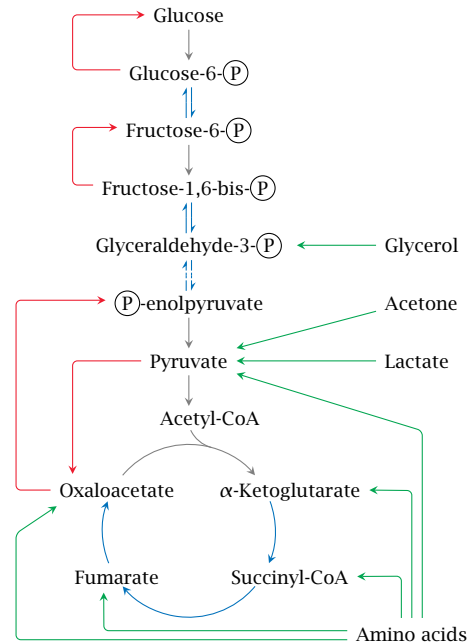

The major substrate supply for gluconeogenesis is protein, both dietary and endogenous. Protein is first broken down into its constituent amino acids. Those amino acids that can be converted to pyruvate or any of the TCA cycle intermediates can serve as substrates for gluconeogenesis, and are therefore called *glucogenic*.

Leucine, lysine and the aromatic amino acids are degraded to acetyl-CoA or acetoacetate. Since acetoacetate is a ketone body, and acetyl-CoA can be converted to ketone bodies, these amino acids are called *ketogenic*. While it was believed for a long time that ketogenic amino acids cannot be converted to glucose in human metabolism, this is not strictly true, since the ketone body acetone can be converted to pyruvate (see slide 10.4.3). Nevertheless, the contribution of ketogenic amino acids to glucose regeneration is likely minor.

Gluconeogenesis proceeds only in the liver and the kidneys, and since the liver is five times larger than the two kidneys combined, it synthesizes most of the glucose. The pathway does *not* occur in the brain, fat tissue, or skeletal muscle. Together with glycogen degradation (see slide 8.3.5), gluconeogenesis ensures stable blood glucose levels between meals. Gluconeogenesis also enables us to maintain the necessary glucose levels when on a diet that is rich in protein but low in carbohydrates.



7.1 Briefly describe the biochemical process of gluconeogenesis.

7.2 Reactions in gluconeogenesis

Most reactions are shared with glycolysis, which we already know, and we here only need to consider the small number of reactions that are specific to gluconeogenesis.

The final reaction in glycolysis is the transfer of the phosphate group from phosphoenolpyruvate (PEP) to ATP. This reaction is irreversible because of the strongly exergonic nature of the accompanying rearrangement of pyruvate from the enol to the keto form (see slide 3.3.7). In gluconeogenesis, it takes two enzymatic steps to turn pyruvate back into PEP, namely (1) the carboxylation of pyruvate to oxaloacetate by pyruvate carboxylase, and (2) conversion of oxaloacetate to PEP by phosphoenolpyruvate carboxykinase.

7.2.1 The pyruvate carboxylase reaction

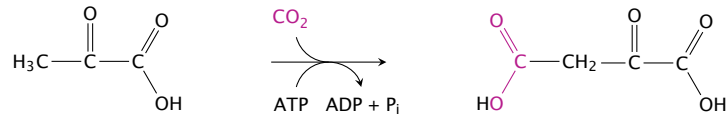

Notes: With the pyruvate carboxylase reaction, we are able to metabolically fix CO_2 —just like plants! Before we try to claim Kyoto treaty credits for this ability, however, it is necessary to consider that the very same molecule of CO_2 gets released again in the next step. The whole purpose of transient CO_2 fixation is to enable this subsequent reaction, which is shown in slide 7.2.4.

7.2.2 The active site of *E. coli* biotin carboxylase

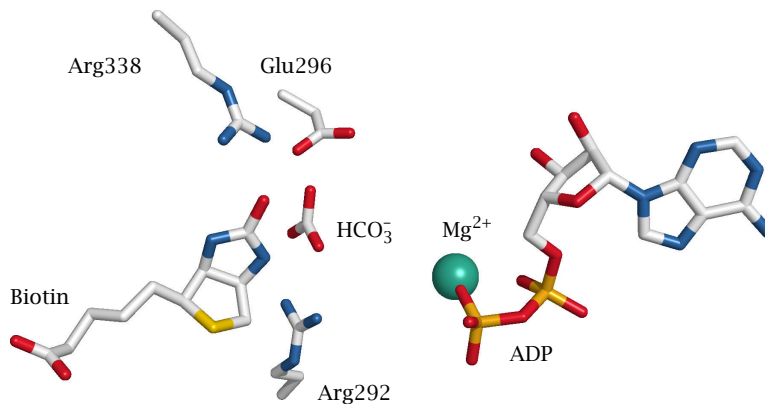

Notes: The pyruvate carboxylase reaction occurs in two separate steps, which in human metabolism are carried out in two distinct active sites of a single enzyme molecule. In *E. coli*, the two activities are found on separate enzyme molecules. The first enzyme activity is biotin carboxylase, which attaches CO_2 to the coenzyme biotin.

The figure (rendered from 3G8C.pdb) shows the location of the reactants, as well as several strategic amino acid residues, within the active site of the *E. coli* enzyme. The reaction involves bicarbonate and ATP; the terminal phosphate group of ATP would fit into the space between ADP, arginine 292, and bicarbonate. The roles of arginine 338 and glutamate 296 are illustrated in the next slide.

7.2.3 Activation of bicarbonate and carboxylation of biotin

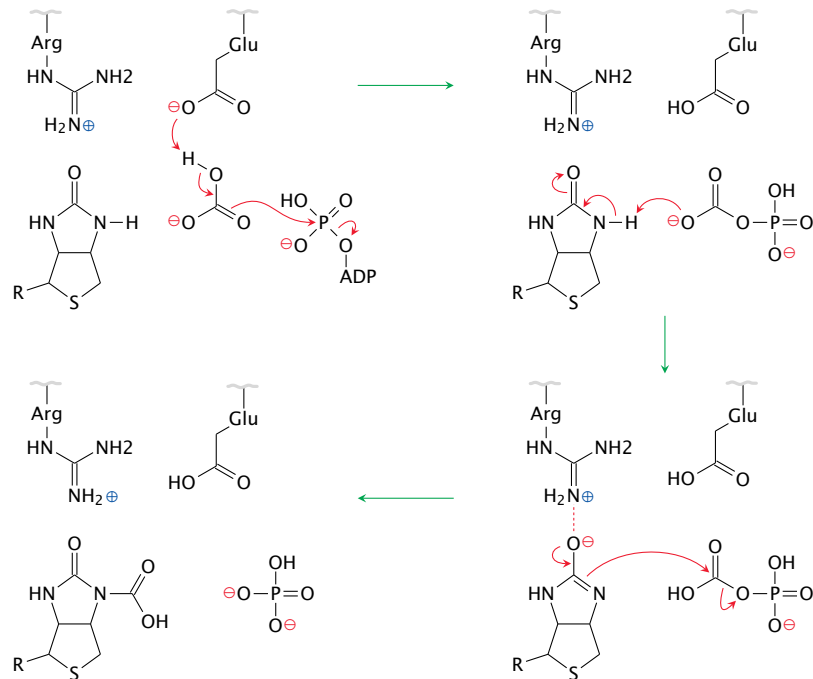

Notes: Glutamate 296 in the active site initiates the proceedings by deprotonating bicarbonate, which in turn attacks the terminal phosphate of ATP. This yields carboxyphosphate, which in turn deprotonates biotin; arginine 338 stabilizes the anionic biotin intermediate that forms transiently at this stage. The biotin anion finally attacks the carboxyphosphate, producing phosphate and carboxybiotin. Figure simplified after a scheme given in [26].

Beyond its role in biotin-dependent carboxylation reactions, carboxyphosphate (or carbonic-phosphoric anhydride) also occurs as an intermediate in the carbamoylphosphate synthetase reaction, which is the first step in the urea cycle (see slide 12.3.1).

7.2.4 The carboxylation of pyruvate

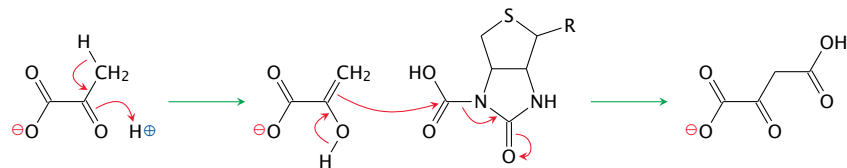

Notes: The second active site—or, in the *E. coli* pathway, the second enzyme—transfers the carboxyl group from biotin to pyruvate. The reaction begins with pyruvate adopting the enoyl configuration. The electrons of the $\text{C}=\text{C}$ double bond then perform a nucleophilic attack on the carboxyl group, to which biotin readily yields. The product is oxaloacetate.



7.2 Describe the mechanism of the pyruvate carboxylase reaction.

7.2.5 The phosphoenolpyruvate carboxykinase reaction

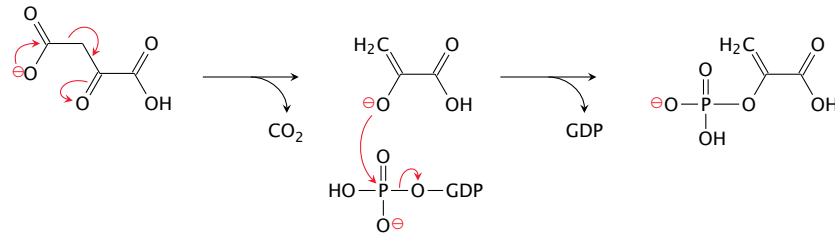

Notes: In the phosphoenolpyruvate carboxykinase reaction, the CO_2 that just had been attached to the substrate leaves again. This gives rise to an enolpyruvate anion intermediate that attacks and acquires the terminal phosphate group of GTP. The product is phosphoenolpyruvate, which is an intermediate of glycolysis. All reactions between phosphoenolpyruvate and fructose-1,6-bisphosphate are reversible; we can therefore skip ahead to the latter metabolite.

7.2.6 Fructose-1,6-bisphosphatase and glucose-6-phosphatase

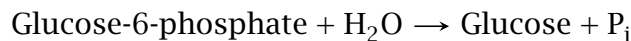
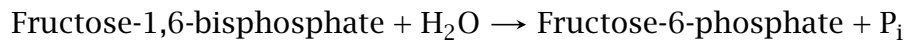

Notes: These reactions revert the substrate phosphorylations that occur in the first and the third step of glycolysis, which are catalyzed by hexokinase and phosphofructokinase, respectively. In gluconeogenesis, the phosphate groups are simply hydrolyzed off, which is not a very difficult sort of reaction.



7.3 Which enzymes in glycolysis catalyze irreversible reactions, and how are these reactions bypassed in gluconeogenesis?

7.3 Energy balance of gluconeogenesis

Reaction	ATP/GTP input
2 pyruvate \rightarrow 2 oxaloacetate	2
2 oxaloacetate \rightarrow 2 PEP	2
2 3-(P)-glycerate \rightarrow 2 1,3-bis-(P)-glycerate	2
Total	6

Notes: Gluconeogenesis requires an input of six equivalents of ATP or GTP for each molecule of glucose. In glycolysis, there was a net gain of only two molecules of ATP per molecule of glucose. The expenditure of an extra four equivalents of ATP in gluconeogenesis reverts the energy balance of the pathway, so that it actually proceeds in the opposite direction. Formation of no more than two ATP

molecules makes it exergonic to turn glucose into pyruvate, whereas expenditure of six ATP equivalents makes it exergonic to turn pyruvate back into glucose.

7.4 Interactions of gluconeogenesis with other pathways

As pointed out above (section 7.1), substrate carbon for gluconeogenesis accrues mostly from amino acid degradation and is harvested at the level of pyruvate or of TCA cycle intermediates. Pyruvate carboxylase, which turns pyruvate into a TCA cycle intermediate, is important not only in gluconeogenesis, but also in the replenishment of TCA cycle intermediates, which may become depleted through diversion to the biosynthesis of amino acids or of heme. Therefore, this enzyme is expressed not only in the organs that perform gluconeogenesis (liver and kidneys) but ubiquitously.

Gluconeogenesis is also part of two interorgan cycles, namely, the Cori cycle and the glucose-alanine cycle. These will be discussed after several other participating pathways have been introduced (see slides 8.5.3 and 12.3.5).

7.4.1 Mitochondrial substrate transport in gluconeogenesis

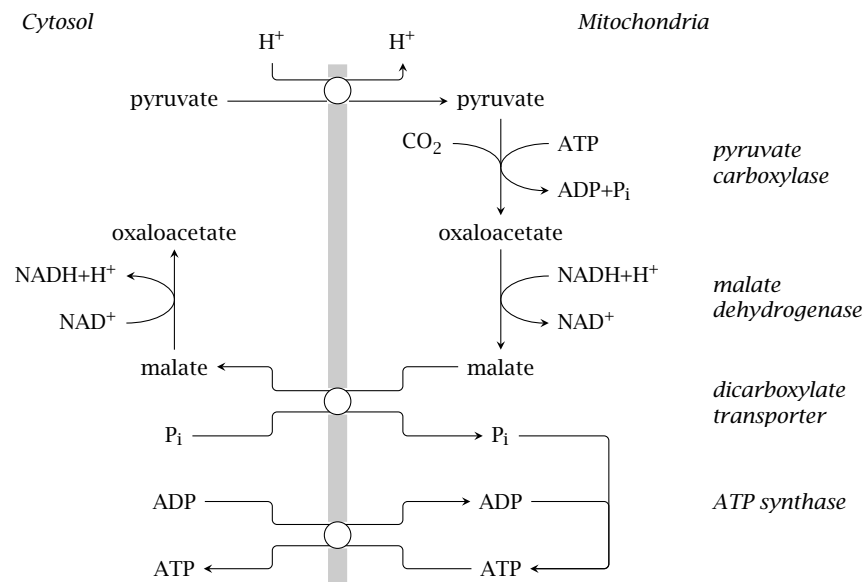

Notes: In keeping with its role in replenishing TCA cycle intermediates, pyruvate carboxylase resides inside the mitochondria. The next step in gluconeogenesis, catalyzed by phosphoenolpyruvate carboxykinase, occurs in the cytosol; therefore, oxaloacetate must in some way be exported from the mitochondria again.

We had already seen that the mitochondrial concentration of oxaloacetate is low, and that the malate dehydrogenase equilibrium favors malate (section 5.5). It turns out that substrate export occurs indeed at the level of malate, which is exchanged for phosphate by a mitochondrial transport protein known as the dicarboxylate carrier. The malate dehydrogenase reaction is then reversed in the

cytosol; the NADH produced can be used in the reversal of the glyceraldehyde-3-dehydrogenase reaction (see slide 3.3.5), which occurs later on in gluconeogenesis.

The phosphate that entered the mitochondrion in exchange for malate can be used by ATP synthase, and the ATP be exchanged for cytosolic ADP, which balances the entire transport cycle and supplies one ATP to the cytosol, where it may for example be used by phosphoglycerate kinase in gluconeogenesis.

The mitochondrial export of malate is susceptible to inhibition by methylmalonate. The coenzyme A thioester of methylmalonate occurs in the metabolic utilization of fatty acids with uneven numbers of carbon atoms (see slide 10.3.6). This pathway requires vitamin B₁₂. A lack of the vitamin will cause free methylmalonate to accumulate. This may inhibit gluconeogenesis and thus account for the clinical hypoglycemia that sometimes accompanies vitamin B₁₂ deficiency [27].



7.4 Explain how oxaloacetate is transported from the mitochondrion to the cytosol to supply gluconeogenesis.

7.4.2 Ethanol degradation inhibits gluconeogenesis

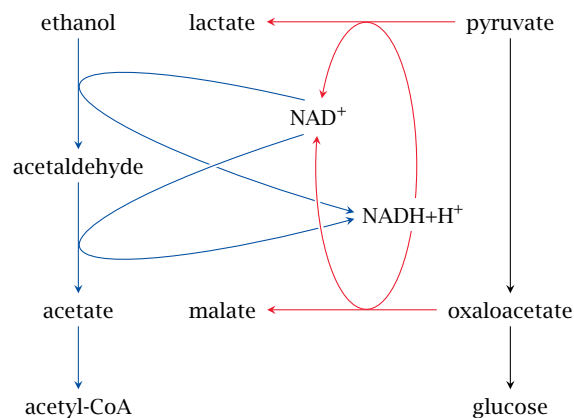

Notes: Like gluconeogenesis, ethanol degradation occurs in the liver. The utilization of one molecule of ethanol by alcohol dehydrogenase and then aldehyde dehydrogenase yields acetate, which is converted to acetyl-CoA by acetate thiokinase.

For each molecule of ethanol degraded, two equivalents of NAD⁺ are reduced to NADH. This raises the cytosolic $[NADH]/[NAD^+]$ ratio, which in turn reduces both pyruvate and oxaloacetate and thus deprives gluconeogenesis of its substrates. In alcoholic patients, this problem is often compounded by a low intake of carbohydrates. Clinically manifest hypoglycemia with unconsciousness is a well-known and potentially dangerous complication in alcohol addiction.



7.5 Explain how alcohol degradation interferes with gluconeogenesis.

7.5 Regulation of gluconeogenesis

The activity of enzymes in gluconeogenesis is regulated by several mechanisms according to the metabolic needs of the cell and those of the entire body.

7.5.1 Simultaneous activity of glycolysis and gluconeogenesis creates futile cycles

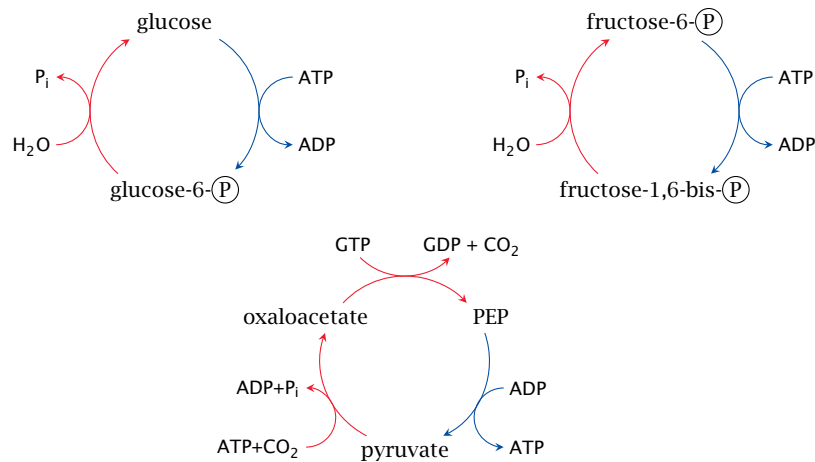

Notes: Each of these short cycles combines one enzyme from glycolysis (blue arrows) with one or two enzymes from gluconeogenesis (red arrows). In each case, the net result of the cycle is simply the consumption of ATP or GTP and the release of heat.

These cycles have been shown to run in living cells at appreciable levels, possibly for the sake of heat production; and as pointed out in chapter 2, such substrate cycles also sharpen up regulatory responses (see slide 2.5.7). Nevertheless, their activity must be kept in check in order to avoid excessive wastage of ATP. Some, but not all of the regulatory mechanisms that exercise this control are understood.

7.5.2 Glucose phosphorylation cycling involves two separate compartments

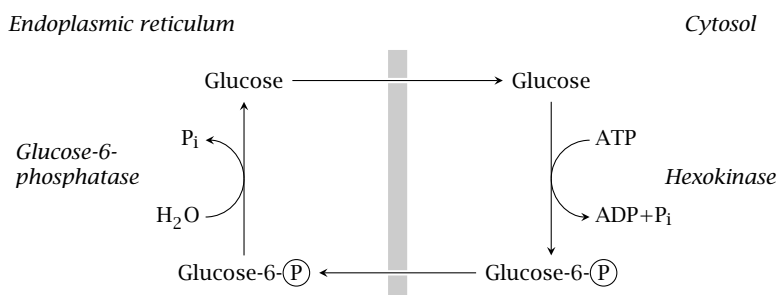

Notes: In this cycle, hexokinase or glucokinase operates in the cytosol, whereas glucose-6-phosphatase is located in the endoplasmic reticulum. It seems likely that flow through the cycle is limited by the capacity of glucose-6-phosphate transport

to the ER. Interestingly, the transporter and the phosphatase are expressed in many tissues, not just those that perform gluconeogenesis [28]; it is not clear at present what, if any, function other than futile cycling this might serve.

7.5.3 Allosteric regulation limits fructose-6-phosphate phosphorylation cycling

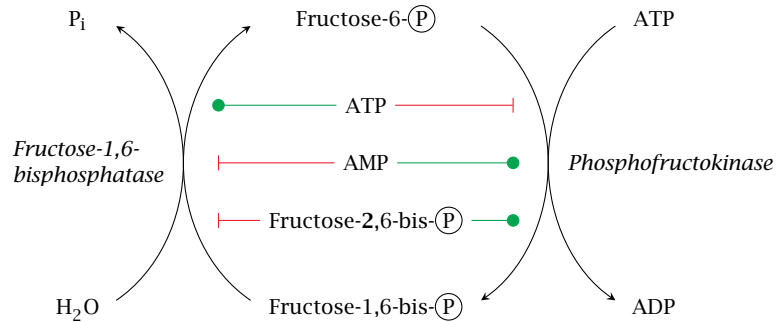

Notes: Phosphofructokinase is inhibited by ATP. This makes sense, since ATP formation is the main purpose of glycolysis, in conjunction with the TCA cycle and the respiratory chain. On the other hand, depletion of ATP will result in a buildup of ADP and AMP; it thus also makes sense that ADP and AMP stimulate phosphofructokinase (section 2.5).

Fructose-1,6-bisphosphatase is stimulated by ATP and inhibited by AMP. This behavior is opposite to that of phosphofructokinase, and it ensures that only one of the two enzymes will be fully active at any given time, which helps to limit the rate of futile cycling.

7.5.4 Hormonal control of phosphofructokinase and fructose-1,6-bisphosphatase

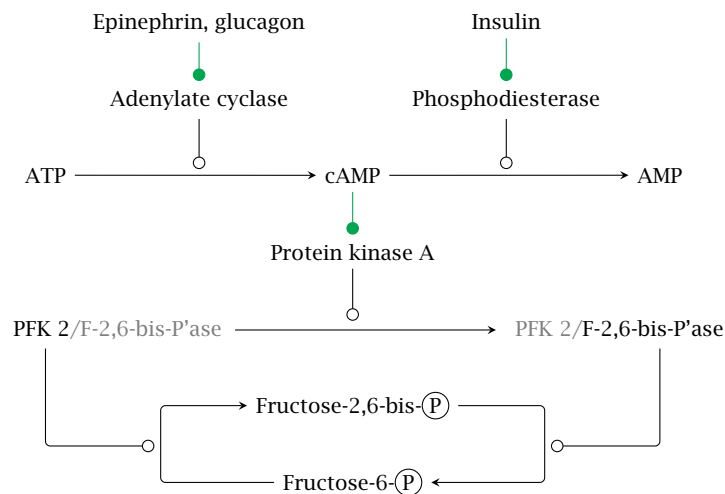

Notes: Phosphofructokinase and fructose-1,6-bisphosphatase also show opposite responses to a third allosteric effector, namely, fructose-2,6-bisphosphate. This molecule is not a regular metabolite of glucose metabolism but is synthesized solely for the sake of its regulation, and it occurs at much lower levels than fructose-1,6-bisphosphate. Its concentration is under the control of hormones via the secondary messenger 3',5'-cyclo-AMP (cAMP). The entire cascade consists of the following stages:

1. The hormones bind to their respective receptors on the cell surface, which then promote the formation of cAMP by adenylate cyclase (glucagon and epinephrine) or its degradation by phosphodiesterase (insulin).
2. cAMP binds to and activates protein kinase A, which phosphorylates the enzyme phosphofructokinase 2 (PFK 2). This phosphorylation can be reversed by a protein phosphatase.
3. PFK 2 has two opposite activities: In the dephosphorylated state, it acts as the kinase and therefore raises the level of fructose-2,6-bisphosphate. In the phosphorylated state, it acts as the corresponding phosphatase and therefore decreases the level of fructose-2,6-bisphosphate.

Since fructose-2,6-bisphosphate activates phosphofructokinase and inhibits fructose-1,6-bisphosphatase, the upshot of glucagon and epinephrine action is to promote gluconeogenesis and inhibit glycolysis. Insulin has the opposite effect. The actions of all these hormones will be considered in more detail in chapter 13.



7.6 Explain the role of fructose-2,6-bisphosphate in the regulation of glycolysis and gluconeogenesis.

7.5.5 The secondary messengers cAMP and fructose-2,6-bisphosphate

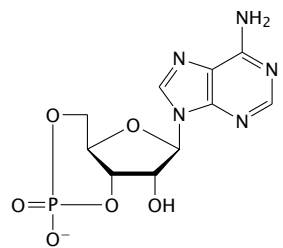

cyclic 3',5'-AMP (cAMP)

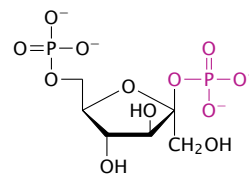

fructose-2,6-bisphosphate

Notes: This slide just shows the structures of the secondary messengers introduced in the previous one. In the structure of fructose-2,6-bisphosphate, the phosphate group attached to the 2'-position is highlighted.

It should be noted that, among the three allosteric effectors of phosphofructokinase and fructose-1,6-bisphosphatase, ATP and AMP reflect the energetic situation of the cell itself, whereas the level of fructose-2,6-bisphosphate is regulated by hormonal stimulation and thus controls the same enzymes on behalf of the needs

of the body as a whole. This is a nice example of how regulatory signals of different origin and meaning are integrated at the molecular level.

7.5.6 Regulation of pyruvate kinase

- allosteric inhibition by ATP
- allosteric activation by alanine and fructose-1,6-bisphosphate
- inhibition by PKA-mediated phosphorylation

Notes: In the third cycle shown in slide 7.5.1, throughput is limited between PEP and pyruvate. The liver form of pyruvate kinase is allosterically activated by fructose-1,6-bisphosphate. It is allosterically inhibited by alanine and by ATP, and it is also inhibited through phosphorylation downstream of cAMP.

The effects of ATP and fructose-1,6-bisphosphate provide some more examples of feedback and feed-forward regulation. Alanine is a key substrate for hepatic gluconeogenesis, since it carries substrate carbon and surplus nitrogen from muscle to the liver in catabolic conditions (see slide 12.3.5); it thus makes sense that alanine should inhibit glycolysis.

Also note that this cycle involves both mitochondrial and cytosolic enzymes, and some of the mitochondrial transporters involved (see slide 7.4.1) might also constrain the flow through this cycle.

7.6 Answers to practice questions

7.1: Gluconeogenesis is the synthesis of glucose from pyruvate or oxaloacetate and their precursors, which include the glucogenic amino acids and lactate. The reactions in this pathway are mostly shared with glycolysis, with workarounds for the irreversible kinase reactions of that pathway. Gluconeogenesis occurs only in the liver and kidneys, not in other organs.

7.2: The reaction occurs in two distinct steps, catalyzed by separate active sites. In the first step, ATP is used to activate bicarbonate to carboxyphosphate, which then transfers CO₂ to biotin. In the second step, biotin yields CO₂ to pyruvate, which transiently adopts enoyl configuration.

7.3: The enzymes in glycolysis are hexokinase, which is bypassed by glucose-6-phosphatase, phosphofructokinase, which is bypassed by fructose-1,6-phosphatase, and pyruvate kinase, which is bypassed by the combined action of pyruvate carboxylase and phosphoenolpyruvate carboxykinase.

7.4: Oxaloacetate is first reduced to malate, which is exchanged for cytosolic phosphate. In the cytosol, malate is converted back to oxaloacetate.

7.5: The oxidation of ethanol in the liver to acetaldehyde and then acetate reduces two equivalents NAD⁺ to NADH. The raised level of NADH promotes the reduction of oxaloacetate to malate and of pyruvate to lactate by malate dehydrogenase and lactate dehydrogenase, respectively. This diverts key substrates from gluconeogenesis.

7.6: Fructose-2,6-bisphosphate allosterically activates phosphofructokinase 1 and inhibits fructose-1,6-bisphosphatase, that is, it promotes glycolysis and inhibits gluconeogenesis.

The formation of fructose-2,6-bisphosphate is under hormonal control; its formation is increased by insulin and decreased by epinephrine and glucagon. These hormonal effects are mediated via cAMP and protein kinase A.

Chapter 8

Glycogen metabolism

8.1 Overview

In addition to gluconeogenesis, the reversible storage of glucose in the form of glycogen provides a second major mechanism of glucose homeostasis.

Glycogen is a branched glucose polymer that is found in many organs, but the largest quantities occur in the liver and in skeletal muscle. The liver can store up to 150-200 grams, which amounts to 10% of the organ's wet weight. It draws from this reservoir to maintain the blood glucose concentration; glycogen plays a major role in day-to-day glucose homeostasis.

While skeletal muscle contains glycogen at much lower concentration than the liver, its much larger overall mass means that the absolute amount of glycogen stored there is approximately twice higher than in the liver. The contribution of muscle glycogen to glucose homeostasis is less well understood.

8.2 Glycogen structure

8.2.1 Why store glucose in polymeric form?

- The osmotic pressure is governed by the gas equation:

$$pV = nRT \Leftrightarrow p = \frac{n}{V}RT$$

- Glycogen amounts to 10% of the liver's wet weight, equivalent to 600 mM glucose
- When free, 600 mM glucose would triple the osmotic activity of the cytosol—liver cells would swell and burst

- Linking 2 (3, ...) molecules of glucose divides the osmotic effect by 2 (3, ...), permitting storage of large amounts of glucose at physiological osmolarity

Notes: The proportionality of concentration and osmotic activity does not strictly apply to large molecules, but the approximation is good enough for the present purpose.



8.1 Why is glucose stored as glycogen?

8.2.2 Covalent structure of glycogen

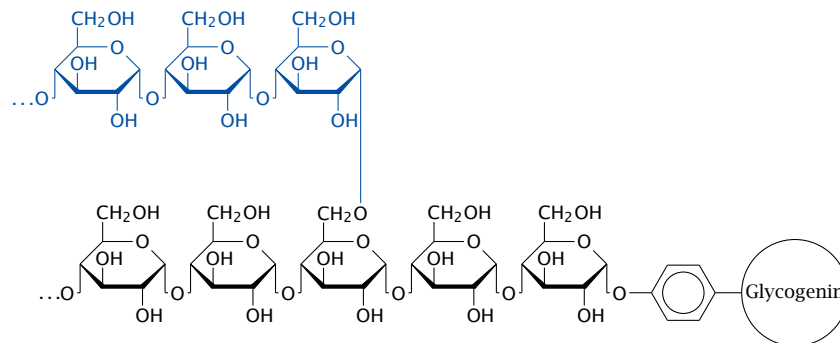

Notes: Glycogen consists of linear stretches of glucose residues connected by α -1 \rightarrow 4-glycosidic bonds, with branches that are attached through α -1 \rightarrow 6-glycosidic bonds. The entire tree-shaped polymer, or *dendrimer*, is rooted in a single molecule of the protein *glycogenin*. Each linear stretch contains approximately 13 glucose residues and, except of course for the outermost layer of the molecule, carries two branches of the same length that are attached 3–4 residues apart.

The structure of glycogen is similar to that of amylopectin (see slide 1.6.11). However, in glycogen, the density of branches is greater, which means that a glycogen molecule has a greater number of free ends than an amylopectin molecule of the same molecular weight. The number of free ends determines the possible rates of synthesis and breakdown, and the greater number of free ends in glycogen than in amylopectin reflects a difference in metabolic rates, which are higher in animals, particularly warm-blooded ones, than in plants.

8.2.3 The size of glycogen particles is limited by crowding in the outer layers

Notes: According to the rules detailed in the preceding slide, the number of branches will double with each successive generational layer of the glycogen molecule. However, the amount of space available to those branches will only grow in proportion to the square of the particle radius or, approximately, the square of the number of generations. Taking into account the actual dimensions and architecture of the polymer, it has been calculated that in the 13th generation the required space would exceed the available space. Therefore, a glycogen molecule can contain no more than 12 generational layers. This implies that a single glyco-

gen molecule can contain up to approximately 54,000 glucose residues; it will have a molecular weight of almost 10^7 Da and a diameter of approximately 25 nm [29].

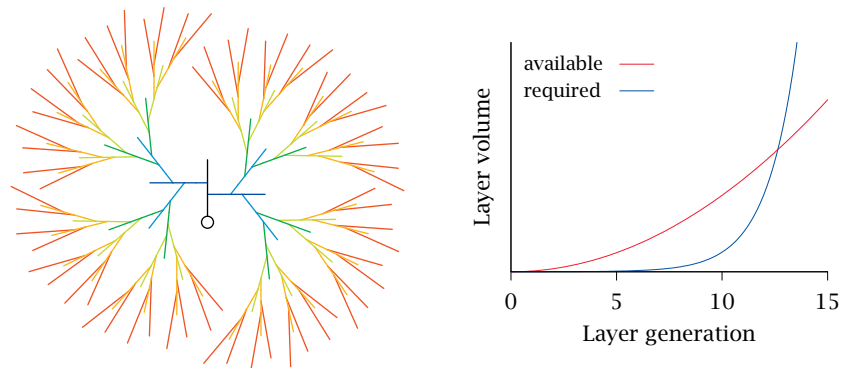

Electron microscopy shows glycogen particles whose dimensions agree well with this theoretical maximum size of single molecules; these are referred to as β particles. In many tissues, variable numbers of β particles are found clustered into so-called α particles. Interestingly, α particles can be broken up with thiol-reducing agents, which implies that they are held together by disulfide bonds. Disulfides usually form between protein molecules. In addition to such scaffolding proteins, glycogen particles also contain a considerable number of enzymes and regulatory proteins [30], some of which will be discussed below.

8.2.4 Glycogen is more loosely packed and more soluble than amylose

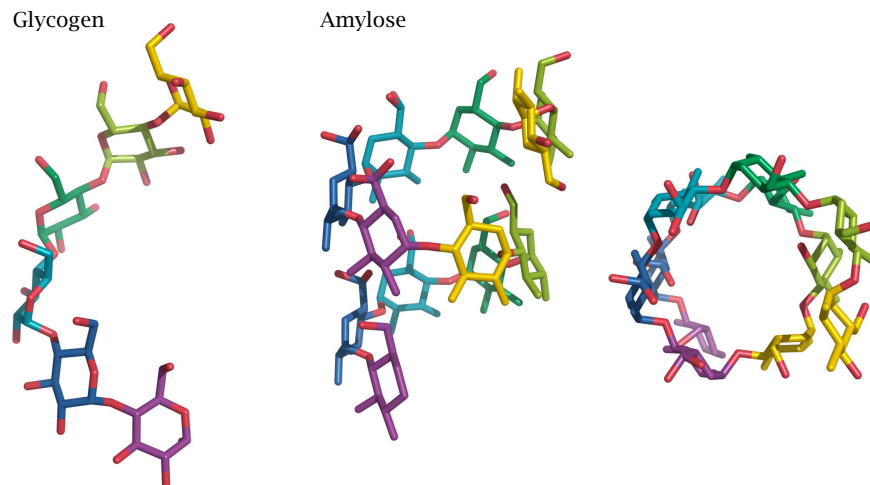

Notes: The above structural model of glycogen assumes a relatively loose packing of the glucose residues within the α -1 \rightarrow 4-linked linear stretches. However, perfectly linear polyglucose—that is, amylose—adopts a much more densely packed helical structure. In this structure, more hydroxyl groups are engaged in hydrogen

bonds with other glucose residues rather than with water; amylose therefore has low aqueous solubility.¹

Unlike amylose, which mostly serves for long-term storage in plant bulbs and seeds, glycogen typically is degraded within hours of synthesis; this rapid turnover is facilitated by its loose structure. However, if branch formation breaks down, aberrant, condensed glycogen particles may arise that are no longer amenable to regular turnover. Various enzyme defects that interfere with branch formation cause the accumulation of such particles inside the cells; an example is the defect of the enzyme *laforin* in Lafora disease (see slide 8.6.4).

Aberrant glycogen particles also arise spontaneously in normal metabolism. The high density of polyglucose chains in the outermost layers of the glycogen molecule may interfere with the activity of branching enzyme and may promote tighter packing. Lysosomal glycogen degradation (see section 8.3.7) may have evolved as a pathway to dispose of such dysfunctional particles.²

8.3 Glycogen synthesis and degradation

The regular, periodic structure of glycogen corresponds to similarly regular and periodic methods of synthesis and breakdown that require only a modest number of enzymes. The following enzyme reactions occur in glycogen synthesis:

Synthesis:

1. synthesis of an activated precursor, UDP-glucose, by UTP:glucose-1-phosphate uridylyltransferase
2. initiation of glycogen synthesis by glycogenin
3. introduction of branches by branching enzyme
4. chain elongation by glycogen synthase
5. repeat steps 3 and 4

Degradation:

1. depolymerization of linear strands by phosphorylase
2. removal of branches by debranching enzyme
3. repeat steps 1 and 2

8.3.1 Activation of glucose for glycogen synthesis

Notes: Both glycogenin and glycogen synthase use an activated form of glucose, UDP-glucose, which is formed from glucose-6-phosphate in two steps. Phosphoglucomutase first transforms glucose-6-phosphate to glucose-1-phosphate (1),

¹Cooking starch has the effect of breaking up hydrogen bonds within amylose and increase its degree of hydration. Amylose thereby becomes digestible by amylase. Cooking food ranks among mankind's greatest inventions, almost comparable to Twitter and the iPad.

²Undegraded insoluble glycogen particles may be seen inside the cells of aged individuals. Such particles are described as *corpora amylacea* in the brain and as *cardiac colloid* in heart muscle.

which is then converted to UDP-glucose (2). The latter reaction requires uridine triphosphate (UTP) and releases pyrophosphate.³

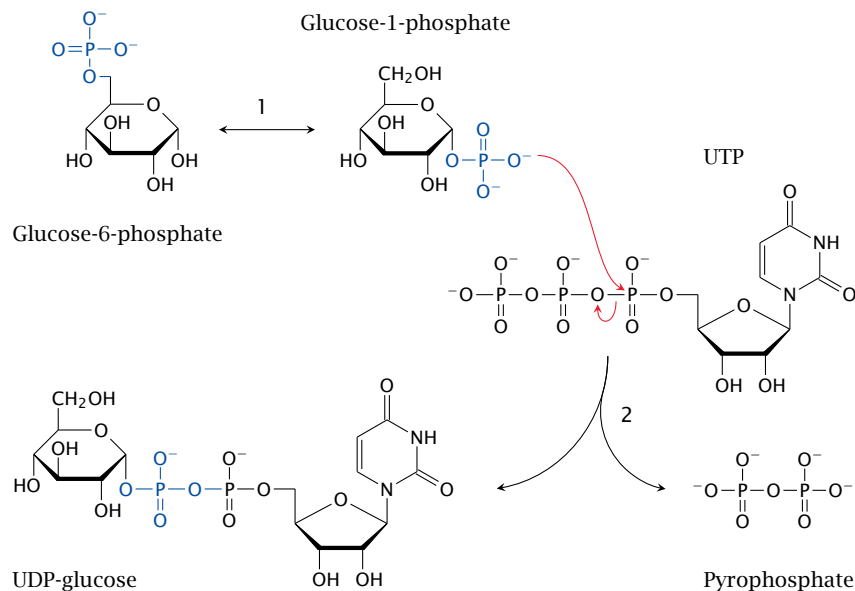

The UDP-glucose that is used in the Leloir pathway of galactose degradation (slide 4.3.1) is derived in the same manner. UDP-glucose is also the precursor of UDP-glucuronic acid, which is used in the conjugation of bilirubin (section 17.4) and of xenobiotics (section 18.3).



8.2 Explain how UDP-glucose is formed, and name its metabolic destinations.

8.3.2 Overview of glycogen synthesis

Notes: Glycogenin is a small bifunctional protein that serves both as the starter substrate and the polymerase that synthesizes the initial linear strand of glucose residues. It begins the synthesis by attaching the initial glucose residue to a strategic tyrosine side chain of itself, and then successively adds several more glucose residues to the sugar's 4' end.

The linear chain synthesized by glycogenin may contain up to ~12 glucose residues. This chain length would be long enough to serve as a substrate for branching enzyme, and it seems likely that the next step is indeed the introduction of the first branch. Alternatively, it is possible that the free end is first extended some more by glycogen synthase before branching occurs. In any event, after branching has occurred, glycogen synthase extends both of the two available 4' ends. The remainder of the molecule is built through the alternating actions of

³Wherever pyrophosphate is released, it is subsequently cleaved to two phosphate ions by pyrophosphatase. This cleavage is strongly exergonic and keeps the concentration of pyrophosphate very low, which in turn makes its release more exergonic. The release of pyrophosphate therefore provides a stronger push to a reaction than the release of monophosphate.

branching enzyme and glycogen synthase; the cycle repeats until the glycogen reaches its inherent size limit at approximately 10 MDa (see slide 8.2.3).

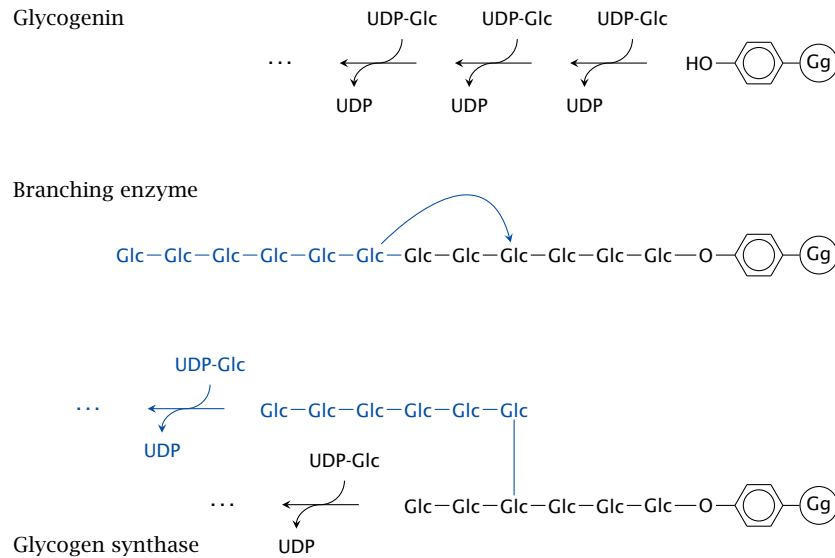

The reactions performed by glycogenin itself and by glycogen synthase are equivalent. It is interesting to note that the carbon 1 of each glucose subunit is in the α -configuration both in UDP-glucose and in glycogen. What does this tell us about the mechanism of the reaction?

8.3.3 A hypothetical reaction mechanism of glycogen synthase

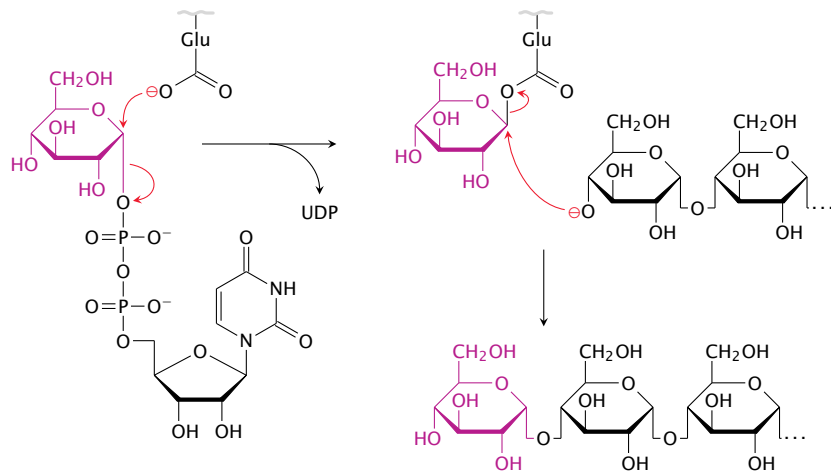

Notes: Nucleophilic substitutions can occur either synchronously or asynchronously. In the first case, which is called the S_N2 mechanism, one substituent leaves as the other arrives; each of them holds on to the same carbon atom with “half a bond” in the transition state. Most commonly, the incoming substituent attacks from the direction opposite to the position of the leaving substituent. With asymmetric carbons such as the C1 of α -D-glucose, this should result in a reversal

to the β configuration. The α configuration may then be restored in a second substitution.

The hypothetical scheme in this slide illustrates such a double S_N2 mechanism. The first substitution leads to a covalent intermediate with an active site glutamate, in which the C1 of glucose has been inverted to the β configuration. The subsequent nucleophilic attack by the activated C4' hydroxyl group restores the α form.

8.3.4 An alternative glycogen synthase mechanism

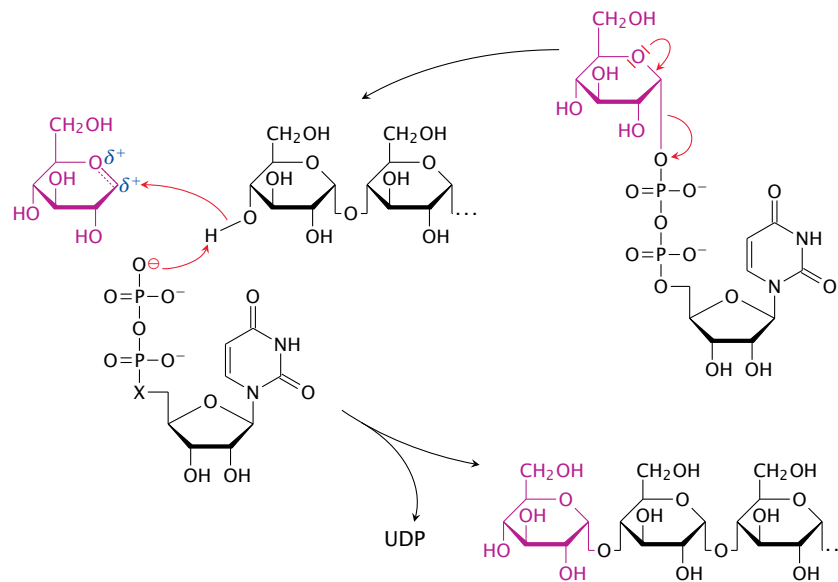

Notes: Double-substitution mechanisms similar to the one shown in the preceding slide are indeed employed by several glycosyltransferases, including glycogen phosphorylase and branching enzyme. However, with glycogen synthase itself, the evidence appears to favor a different mechanism that does not involve covalent catalysis by the enzyme, but instead a direct activation of both the C1 of the incoming glucose and the C4' hydroxyl group of the preceding chain [31], as is depicted in simplified form in this slide. Note how the UDP that is released in the first step of the reaction assumes a catalytic role in the second step.

8.3.5 Overview of glycogen degradation

Notes: Glycogen degradation is brought about by phosphorylase and debranching enzyme. All glucose residues that are joined by α -1 \rightarrow 4-glycosidic bonds—that is, those in the straight segments—are released by glycogen phosphorylase. Most enzymes that cleave glycosidic bonds simply hydrolyze them; examples are intestinal amylase and β -galactosidase. In contrast, glycogen phosphorylase employs phosphate ions instead of water, and so produces glucose-1-phosphate rather

than free glucose.⁴ Glucose-1-phosphate is then converted to the mainstream metabolite glucose-6-phosphate by phosphoglucomutase.

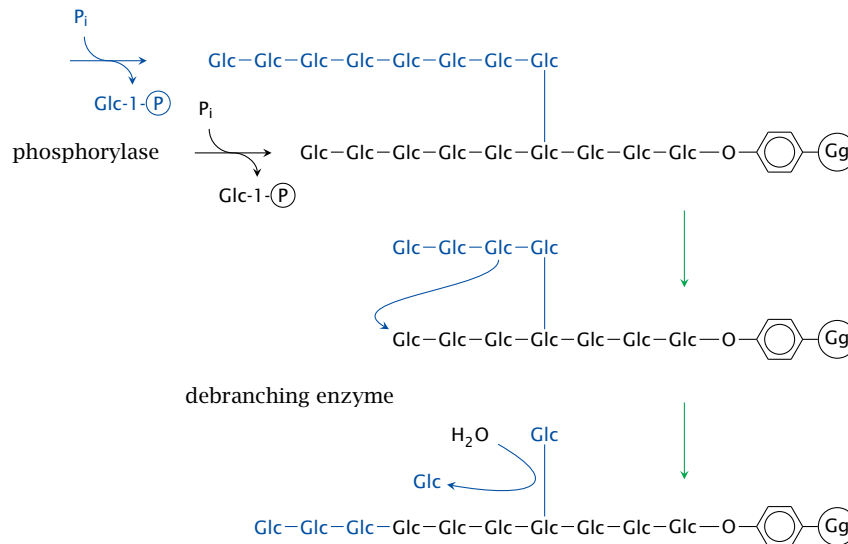

In the liver, which stores glycogen for the benefit of the entire body, the lion's share of glucose-6-phosphate will be dephosphorylated by glucose-6-phosphatase and then released into the circulation; overall, this is equivalent to outright hydrolysis. However, muscle uses glycogen largely toward its own energy needs, and therefore glucose-6-phosphate will usually be funneled straight into glycolysis. In this case, the use of phosphorolysis instead of hydrolysis bypasses the hexokinase reaction, thereby saving one equivalent of ATP.⁵

Glycogen phosphorylase only degrades the chain ends to within four residues of a branching point. Then, debranching enzyme takes over and transplants the stub to another free end, where it becomes again a substrate for phosphorylase. However, this reaction leaves behind a single residue attached by a α -1 \rightarrow 6-glycosidic bond. This residue is subsequently released by the same enzyme as free glucose through hydrolysis.



8.3 Give a summary of glycogen synthesis and degradation.

8.3.6 The reaction mechanism of phosphorylase

Notes: Glycogen phosphorylase uses pyridoxal phosphate (PLP) as a coenzyme. If you are familiar with the usual catalytic role of PLP, you may find this surprising; and indeed, phosphorylase employs it PLP a unique manner that bears no resemblance to its typical role in amino acid metabolism (see for example section 12.2). In those reactions, the organic ring of PLP, which is grayed out in this figure, func-

⁴Phosphorolysis also occurs in the release of ribose and deoxyribose from nucleosides (see section 16.4).

⁵Glycogen arose early in evolution, and the glycogen usage pattern of early organisms likely resembled muscle rather than liver tissue. Therefore, the energy efficiency of phosphorolysis was advantageous to those early organisms, too.

tions as a reversible “electron sink.” In contrast, glycogen phosphorylase mainly uses the phosphate group of PLP, which it deploys to prime a free phosphate ion for attack on the terminal glycosidic bond of the glycogen substrate.

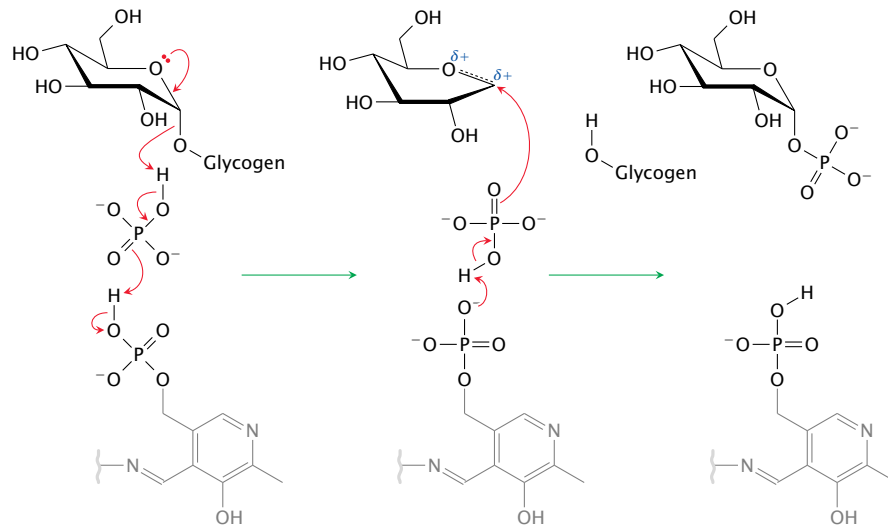

8.3.7 Lysosomal glycogen disposal

- concerns a minor fraction of glycogen
- key enzyme: acid maltase; enzyme defect causes slow but inexorable glycogen accumulation
- possible role: disposal of structurally aberrant glycogen particles that have become “tangled up” during repeated cycles of glucose accretion and depletion

Notes: In liver cells, approximately 10% of all glycogen particles are found inside lysosomes [30], where they undergo slow degradation by *acid maltase*. This enzyme catalyzes the same reactions as intestinal amylase and maltase (see slide 1.6.12) but has an acidic pH optimum, in keeping with the acidic environment inside lysosomes (pH ~4.5). The lysosomal degradation pathway is important for the disposal of structurally aberrant glycogen particles; additional metabolic roles may exist but are currently not well understood. An enzyme defect for lysosomal maltase causes Pompe’s disease (slide 8.6.2).

8.4 Regulation of glycogen metabolism

We have seen in slide 7.5.4 that phosphofructokinase and the complementary enzyme fructose-1,6-bisphosphatase are regulated by both intracellular and extracellular signals. The same applies to the key enzymes in glycogen metabolism.

8.4.1 Allosteric regulation of glycogen synthase and phosphorylase

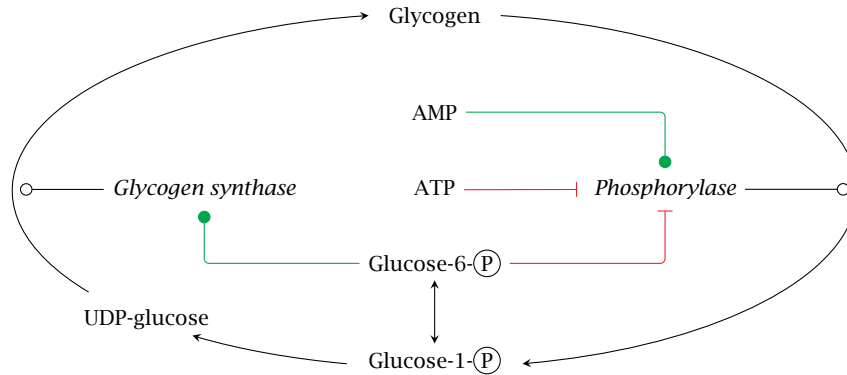

Notes: The allosteric regulatory effects exercised by glucose-6-phosphate, ATP and AMP on glycogen phosphorylase and glycogen synthase make good physiological sense. Depletion of ATP is an excellent reason to release glucose from the store in order to make some more. On the other hand, glucose-6-phosphate will be plentiful when glucose itself is abundant, and therefore signals an opportunity for replenishing the glycogen stores.



8.4 Explain the allosteric regulation of glycogen synthase and phosphorylase.

8.4.2 Hormonal control of glycogen metabolism

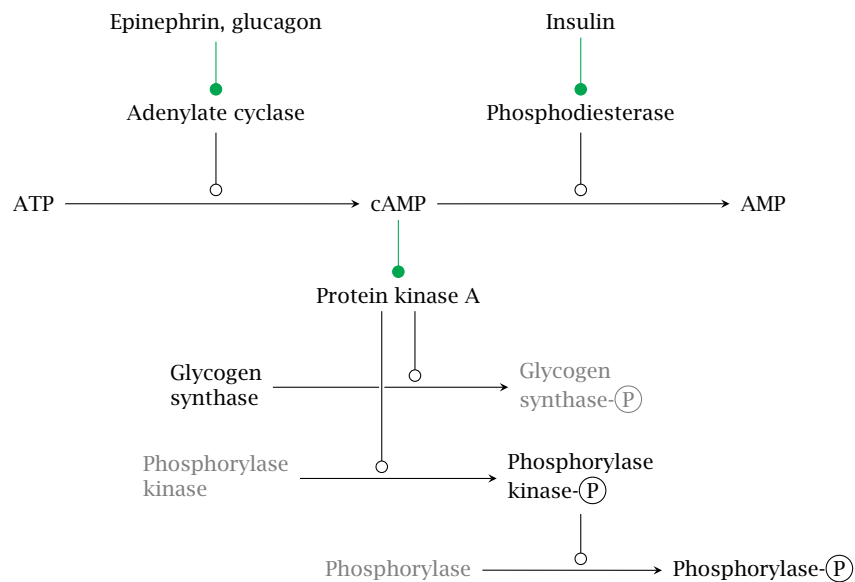

Notes: Hormonal control of glycogen metabolism is similar to that of gluconeogenesis; the cascade shown here is identical to that shown in slide 7.5.4 all the way from the hormones to the activation of protein kinase A. The activated kinase directly phosphorylates glycogen synthase, which inactivates that enzyme. Protein kinase A indirectly stimulates glycogen breakdown by phosphorylation of a

dedicated regulatory enzyme, phosphorylase kinase, which in turn phosphorylates glycogen phosphorylase.

Note that glycogen synthase and phosphorylase respond in opposite ways to phosphorylation: The synthase is inactivated, whereas the phosphorylase is activated.



8.5 Explain the hormonal control of glycogen synthase and phosphorylase.

8.4.3 Regulatory differences between liver and muscle phosphorylase

	Liver enzyme	Muscle enzyme
Inhibition by glucose	+	-
Activation by Ca^{2+}	-	+
Activation by AMP even when unphosphorylated	-	+

Notes: There are regulatory differences between glycogen phosphorylase in muscle and liver. Glucose inhibits the liver enzyme but not the muscle enzyme, and Ca^{2+} stimulates the muscle enzyme but not the liver enzyme. Recall that Ca^{2+} is also the trigger for muscle contraction; the simultaneous stimulation of glycogen breakdown therefore anticipates an increased demand for ATP.

As one would expect from their regulatory differences, the phosphorylases in liver and muscle are different molecules. Enzymes that catalyze the same reaction yet are separate molecules are referred to as *isozymes*. Although we usually don't mention it, many other enzymes covered in this text occur as multiple isozymes, too.



8.6 Explain the physiological function of glycogen.

8.5 Interorgan relationships in glycogen metabolism

As stated above, the two tissues that have the most significant pools of glycogen are the liver and skeletal muscle. Liver glycogen is turned over rapidly; it serves as the major reserve of blood glucose during short-term fasts. Once liver glycogen is depleted, muscle glycogen can be drawn down; this, however, requires some roundabout metabolic trickery.

8.5.1 Liver glycogen utilization

Notes: The liver mobilizes glucose from its glycogen store via glycogen phosphorylase and phosphoglucomutase, which yields glucose-6-phosphate. The latter is transported to the endoplasmic reticulum, where it is dephosphorylated. Glucose is taken back to the cytosol and released into the bloodstream.

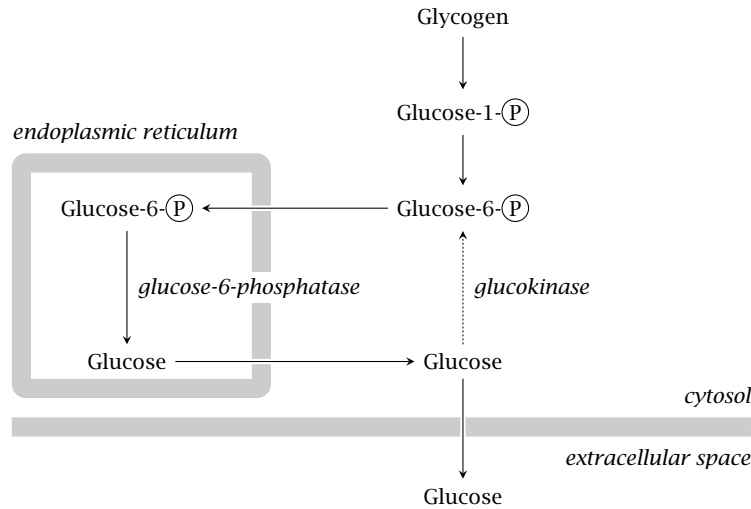

Some of the glucose will be rephosphorylated before making it out of the cell, creating the futile cycle discussed in slide 7.5.2. However, the dominant glucose phosphorylating enzyme in the liver is glucokinase, which has fairly low affinity for glucose (see slide 3.5.3); therefore, enough glucose will escape rephosphorylation and be released into the bloodstream.

8.5.2 Muscle glycogen utilization

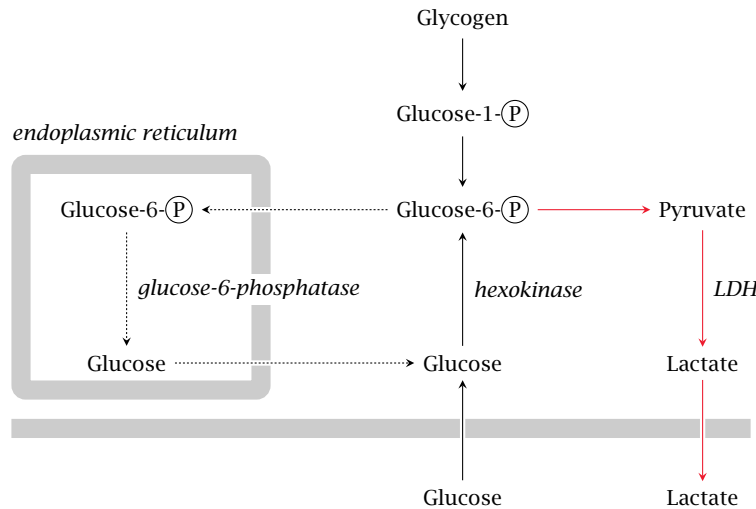

Notes: Muscle glycogen primarily serves the energy needs of muscle tissue itself; during prolonged physical exercise, most of it is broken down to glucose-6-phosphate and then consumed via the usual pathways right within the cells that stored it. As discussed above, this usage is facilitated by calcium-mediated activation of glycogen phosphorylase.

Under suitable conditions, namely, prolonged fast without physical exercise, muscle glycogen can also contribute to the replenishment of blood glucose. However, even though muscle cells have been shown to express glucose-6-phosphatase

[32] and thus are, in principle, able to produce free glucose, they should find it difficult to release it. This is because muscle contains hexokinase, which has a much greater substrate affinity than glucokinase and therefore will keep the intracellular level of free glucose well below the extracellular concentration. The net transport of glucose should therefore be directed inward at all times; this agrees with all the physiological evidence that I could find.

The way around this obstacle is to convert glucose-6-phosphate to pyruvate and then lactate. At a low rate, lactate formation occurs even in resting muscle and under aerobic conditions. This lactate is derived in various proportions from blood glucose and glycogen, respectively. In animal experiments, epinephrine promotes glycogen utilization and lactate release [33], but overall the hormonal control of this process and the magnitude of its contribution to systemic glucose control are not well characterized.



8.7 Explain how substrate carbon derived from muscle glycogen may be made available to bolster blood glucose levels.

8.5.3 The Cori cycle

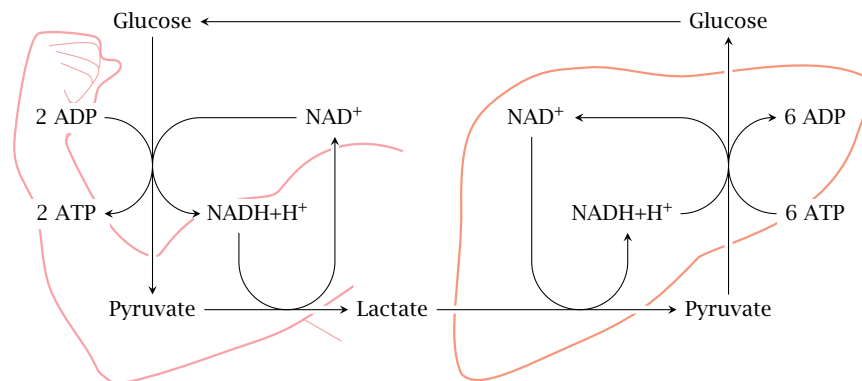

Notes: While skeletal muscle relies on oxidative metabolism most of the time, some other tissues, notably red blood cells and lymphocytes, which collectively account for some 4 kg of cell mass, depend mostly or even exclusively on anaerobic glycolysis even under aerobic conditions. The lactate released in peripheral tissues is scooped up by the liver, which converts it back to glucose through gluconeogenesis. This process is known as the Cori cycle, named after its discoverers Carl and Gerti Cori, who worked it out as early as 1929 [34].

Skeletal muscle produces lactate at a very much higher rate during short bouts of maximal exercise when the ATP demand exceeds the capacity for aerobic metabolism. Some textbooks state that the Cori cycle resupplies the muscle with glucose in this situation also. This is, however, quite impossible. During intense exercise, the cardiac blood output is diverted from the visceral organs to skeletal muscle. Therefore, when ATP demand exceeds the oxygen supply of skeletal muscle, the oxygen shortfall would be even greater in the liver, should it indeed attempt to make enough ATP for sustaining the muscle through gluconeogenesis; and even

with sufficient oxygen, its capacity for making glucose would fall far short of the muscles' voracious appetite.

Anaerobic exercise can be sustained for only short periods of time anyway. During this period, the lactate turned out by skeletal muscle will simply accumulate; it will then slowly be scooped up by the liver and turned back into glucose *after* we have collapsed at the side of the track to catch our breath.



8.8 Describe the Cori cycle.

8.6 Glycogen storage diseases

Genetic defects have been described for several enzymes of glycogen metabolism. The clinical syndromes associated with these defects are referred to as glycogen storage diseases. While these conditions are not particularly common, they do shed some light on the physiological significance of glycogen metabolism. Some conditions are clinically severe and are the focus of ongoing therapeutic research. A few examples are briefly discussed below.

8.6.1 Glucose-6-phosphatase deficiency (von Gierke disease)

- glucose formed in gluconeogenesis or released from glycogen cannot be exported from liver and kidney cells
- glycogen builds up in liver and kidneys
- severe hypoglycemia
- lactic acidosis
- hyperlipidemia
- hyperuricemia

Notes: Gluconeogenesis and glycogen degradation in liver and kidneys produce glucose-6-phosphate, which must then be dephosphorylated to glucose in order to be exported into the bloodstream (see slide 8.5.1). An enzyme defect for glucose-6-phosphatase prevents glucose release, which causes abnormally low blood glucose levels (hypoglycemia). Some of the surplus glucose accumulates as glycogen, whereas the remainder is converted to pyruvate in glycolysis and either emerges as lactate or, downstream of pyruvate dehydrogenase, is turned into triacylglycerol and cholesterol; the excess lactate and lipids account for the observed lactic acidosis and hyperlipidemia.

The causation of hyperuricemia—excess blood levels of uric acid, see section 16.5—is less obvious. During episodes of hypoglycemia, the liver will be intensely stimulated by glucagon and epinephrine and make a forceful but futile attempt to mobilize its stored glycogen. The large amount of glucose-6-phosphate produced in this attempt, which cannot be converted to glucose, ties up and depletes cellular

phosphate. This impedes the regeneration of ATP and raises the level of AMP, some of which then enters degradation to uric acid [35].⁶

The clinical severity of this disease may vary, presumably due to different levels of residual enzyme activity. Some cases may be managed with a diet of frequent, starch-rich meals, which helps to avoid hypoglycemia. In more severe cases, liver transplantation may become necessary.

 **8.9** Name the enzyme defect that underlies von Gierke disease, and explain why it gives rise to hypoglycemia.

8.6.2 Acid maltase deficiency (Pompe disease)

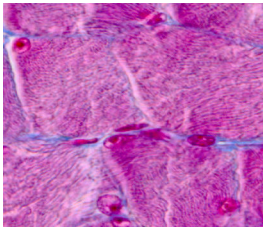

Normal skeletal muscle (transverse section)

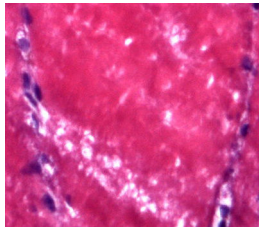

Glycogen aggregates in Pompe disease



Infant chest X-ray, normal heart



Infant with Pompe disease, distended heart

Notes: A homozygous deficiency of acid maltase⁷ disrupts lysosomal glycogen degradation and results in glycogen accumulation. Skeletal and heart muscle are more strongly affected than the liver. The tissue section of diseased muscle tissue shows “white holes,” which represent unstained aggregates of glycogen particles. Glycogen accumulation interferes with muscle cell function and contraction, and heart failure—a heavily impacted, severely distended heart is shown here in an X-ray image—leads to death.

The condition, which is known as Pompe’s disease, can vary in severity; complete lack of enzyme activity becomes manifest in infants, whereas mutations that reduce but do not completely inactivate the enzyme will cause milder disease with onset deferred to later childhood or adolescence. The disease can be treated with enzyme replacement therapy. The recombinant enzyme preparation is FDA-approved; its price is astronomical. This therapeutic approach is more thoroughly discussed in section 19.3.

8.6.3 Muscle phosphorylase deficiency (McArdle’s disease)

- Deficient glycogen breakdown inhibits rapid ATP replenishment
- Patients experience rapid exhaustion and muscle pain during exertion
- Liver phosphorylase and blood glucose homeostasis remain intact

⁶This mechanism bears some resemblance to the hyperuricemia that can be triggered in healthy patients through fructose overload (see slide 16.6.4).

⁷Maltose is a suitable model substrate, but the real role of this “maltase” enzyme is to cleave the $\alpha \rightarrow 4$ -glycosidic bonds in glycogen.

Notes: Since liver and muscle phosphorylase are distinct isozymes, defects usually affect one and spare the other.⁸ In McArdle's disease, the muscle isoform is selectively affected. An unexplained symptom in this disease is the so-called "second wind" phenomenon: during physical activity, patients initially fatigue rapidly, but then recover to a degree under continued exercise.

The lack of muscle phosphorylase should also inhibit the utilization of muscle glycogen toward blood glucose stabilization by way of the Cori cycle (see slide 8.5.3); one might therefore expect that McArdle's disease might involve episodes of hypoglycemia. Interestingly, however, the literature does not contain reports of hypoglycemia in these patients.

8.6.4 Lafora disease

- deficiency for laforin, a glycogen phosphatase
- accumulation of hyper-phosphorylated glycogen (Lafora bodies)
- patients develop epilepsy, dementia

Notes: Laforin is a phosphatase that is associated with glycogen particles and removes phosphate groups from glycogen itself [37]. The functional significance of glycogen phosphorylation and dephosphorylation is not clear; and you will notice that it was not even mentioned above. However, genetic deficiencies of the phosphatase lead to the accumulation of Lafora bodies, which consist of phosphorylated, poorly branched glycogen molecules. The disease becomes manifest through a specific form of epilepsy (myoclonic seizures) and dementia and is fatal. The CNS symptoms—like the involvement of the kidneys in v. Gierke disease, see above—illustrate that tissues other than liver and muscle contain glycogen as well and may be damaged by its accumulation.

8.7 Answers to practice questions

8.1: Conversion of glucose to a polymeric form greatly reduces the osmotic activity of glucose and thus allows it to be stored at much higher density than would otherwise be compatible with physiological osmotic conditions.

8.2: UDP-glucose is formed from glucose via glucose-6-phosphate and glucose-1-phosphate by hexokinase, phosphoglucomutase, and glucose-1-phosphate uridyltransferase. The latter enzyme also requires UTP and releases pyrophosphate. UDP-glucose serves a catalytic role in galactose utilization and is the precursor of glycogen and of UDP-glucuronic acid, which in turn serves as a cosubstrate in bilirubin and drug conjugation reactions.

8.3: See the enumeration of reaction steps at the beginning of section 8.3.

8.4: Phosphorylase is activated by AMP and inhibited by ATP and glucose-6-phosphate. Glycogen synthase is activated by glucose-6-phosphate.

8.5: Glucagon or epinephrine activate adenylate cyclase, which produces cAMP, while insulin activates phosphodiesterase, which reduces cAMP. When it is high enough, cAMP

⁸The two enzymes do share a common subunit, which may occasionally may be deficient also [36].

activates protein kinase A, which directly phosphorylates and thereby inactivates glycogen synthase. The kinase also phosphorylates a secondary kinase that phosphorylates, and thereby activates, glycogen phosphorylase.

8.6: Glycogen is a polymeric form of glucose that allows storage of the latter in large amounts. The highest concentrations are found in the liver. Liver, and possibly muscle cells, store glucose as glycogen under the influence of insulin, and they degrade glycogen to glucose and release it into the circulation under the influence of glucagon and epinephrine. The synthesis and degradation of glycogen helps to maintain a stable blood glucose concentration through phases of varying supply and demand.

8.7: Skeletal muscle contains all enzymes for converting glycogen to glucose, but due to its content of hexokinase is likely unable to accumulate enough free glucose to effect its release into the circulation. However, glycogen-derived glucose may be converted to pyruvate and then lactate, which may be released and enter gluconeogenesis in the liver.

8.8: The Cori cycle is an interorgan cycle, combining gluconeogenesis in the liver with anaerobic glycolysis in peripheral tissues. It enables the disposal and utilization of lactate formed in anaerobic glycolysis.

8.9: The deficient enzyme is glucose-6-phosphatase. Without it, the liver and kidney are unable to release free glucose formed through glycogen degradation and gluconeogenesis, which are the key pathways for blood glucose stabilization—that is, prevention of hypoglycemia—in fasting periods.

Chapter 9

The hexose monophosphate shunt

9.1 Outline of the pathway

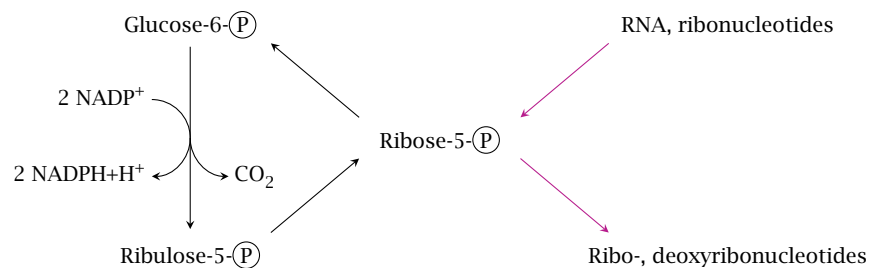

Notes: The previous chapters have shown that glucose-6-phosphate has a central place in carbohydrate metabolism. This chapter describes yet another pathway that starts with this key metabolite, namely, the hexose monophosphate shunt, or HMS for short. Since this pathway comprises both pentoses and hexoses, it is sometimes also referred to as the *pentose phosphate pathway*. It serves two major functions that are important for biosynthesis, namely (1) the regeneration of NADPH from NADP^+ , and (2) the provision or utilization of ribose. Within the pathway, we can distinguish two phases:

1. the oxidative phase, in which glucose-6-phosphate is oxidized and decarboxylated to ribulose-5-phosphate, and which yields two equivalents of NADPH, and

2. the regenerative “sugar shuffle” phase, which converts ribulose-5-phosphate back to $5/6$ equivalents of glucose-6-phosphate.

If all the glucose-6-phosphate formed in the regenerative phase reenters the oxidative phase in each turn of the cycle, all of it will eventually be completely oxidized to CO_2 , with the production of 12 equivalents of NADPH. Therefore, the hexose monophosphate shunt provides an alternate pathway for the complete degradation of glucose to CO_2 . While the sequence of glycolysis, PDH and TCA cycle involves both the cytosol and the mitochondria, the HMS runs entirely in the cytosol. This ties in with the fact that most of the biosynthetic reactions that require NADPH also occur in the cytoplasm or in the ER, rather than in the mitochondria. It also means that the HMS is present in red blood cells, which lack mitochondria.

The oxidative and the regenerative phases of the HMS can occur at the same time, but they can also function independently from one another. This allows net flux through the pathway to follow alternative patterns in different metabolic situations:

1. NADPH regeneration. Complete oxidation of glucose-6-phosphate, with maximum yield of NADPH and without any net formation or utilization of other sugars, occurs when the oxidative phase and the regenerative phase occur in lockstep.

2. Nucleotide biosynthesis. One of the sugar phosphate intermediates of the regenerative phase is ribose-5-phosphate, which also serves as a precursor of nucleotides and nucleic acids. If required, ribose-5-phosphate can be diverted toward nucleotide biosynthesis, with a corresponding reduction in the yield of regenerated glucose-6-phosphate. Since all reactions in the regenerative phase are reversible, glucose-6-phosphate can in principle also be converted to ribose-5-phosphate without any concomitant net oxidation.

3. Ribose utilization. With a typical diet that is reasonably rich in starch, the net flow through the sugar shuffle will be from hexoses to pentoses. However, when eating meat only, our intake of ribose in the form of RNA will be a very significant fraction of the total dietary carbohydrates, and the net flow in the hexose monophosphate shunt will likely go the opposite way (see section 16.4).



9.1 Name the three metabolic functions served by the hexose monophosphate shunt.

9.2 Reactions in the hexose monophosphate shunt

9.2.1 Reactions in the oxidative stage

Notes: Three enzymes are required in the oxidative phase:

1. Glucose-6-phosphate dehydrogenase oxidizes glucose-6-phosphate to 6-phosphogluconolactone and reduces one molecule of NADP^+ to NADPH.

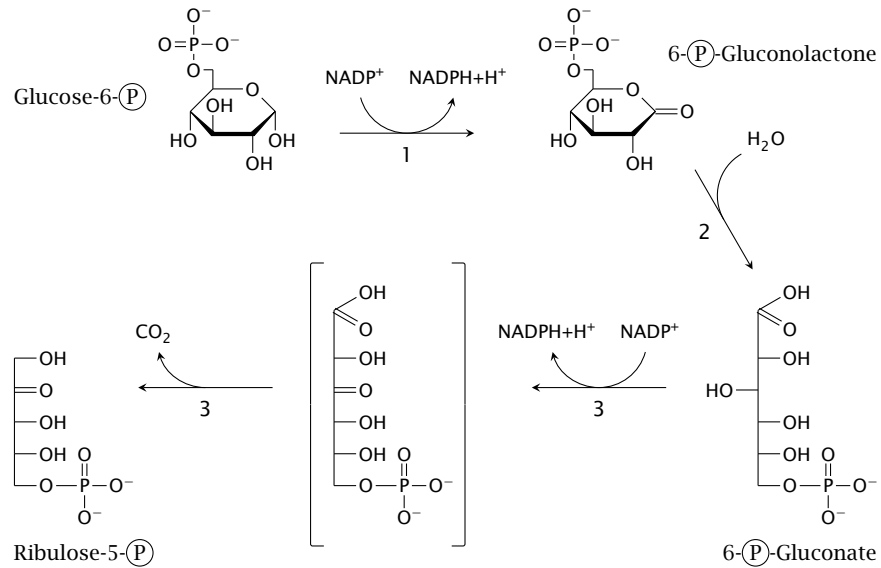

2. Gluconolactonase cleaves the internal ester bond, which gives 6-phosphogluconate.
3. 6-Phosphogluconate dehydrogenase reduces another molecule of NADP⁺ and decarboxylates 6-phosphogluconate to the pentose ribulose-5-phosphate.

After completion of these three initial reactions, NADPH generation is over, and all that remains is to juggle sugars in order to regenerate hexoses from pentoses.

9.2.2 Reactions in the sugar shuffle stage

Notes: The sugar shuffle stage involves the enzymes ribulose-5-phosphate epimerase (RE), ribulose-5-phosphate isomerase (RI), transketolase (TK), and transaldolase (TA). They bring about the following reactions:

1. Two molecules of ribulose-5-phosphate are converted to xylulose-5-phosphate by ribulose-5-phosphate epimerase, and a third one is converted to ribose-5-phosphate by ribulose-5-phosphate isomerase.
2. Transketolase transfers a C₂ unit from one xylulose-5-phosphate to the ribose-5-phosphate, yielding glyceraldehyde-3-phosphate and the C₇ sugar sedoheptulose-7-phosphate.
3. Transaldolase transfers a C₃ unit from sedoheptulose-7-phosphate back to glyceraldehyde-3-phosphate, which yields fructose-6-phosphate and the C₄ sugar erythrose-4-phosphate.
4. Transketolase transfers a C₂ unit from the second molecule of xylulose-5-phosphate to erythrose-4-phosphate. This yields a second molecule of fructose-6-phosphate and again glyceraldehyde-3-phosphate.

At the conclusion of the reactions depicted in this slide, three molecules of ribulose-5-phosphate have been converted to two molecules of fructose-6-phosphate and one molecule of glyceraldehyde-3-phosphate. Fructose-6-phosphate can

be converted to glucose-6-phosphate in one step by phosphohexose isomerase, a glycolytic enzyme.

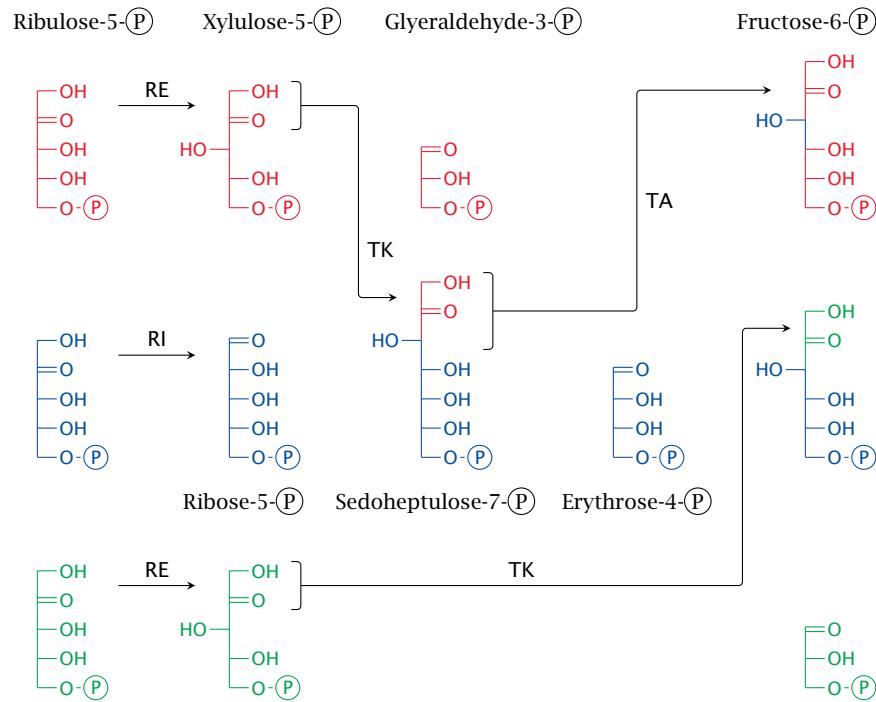

Conversion of glyceraldehyde-3-phosphate to glucose-6-phosphate would require several enzymes from glycolysis as well as fructose-1,6-bisphosphatase, which otherwise is required only in gluconeogenesis. I have not been able to ascertain whether or not tissues that don't perform gluconeogenesis produce this enzyme to serve in the hexose monophosphate shunt. Also recall that two molecules of triose phosphate are needed in the aldolase reaction to form one molecule of fructose-1,6-bisphosphate. This results in an overall stoichiometry of 2.5 molecules of hexose per 3 molecules of pentose, or five hexoses per six pentoses.

9.2.3 Ketoses and aldoses in the HMS

Notes: The shuffling of sugars differing in chain length is brought about by just two enzymes, namely, transaldolase and transketolase. While the sugar substrates they act upon may appear to be quite varied at first glance, they fall into just two homologous classes, within each of which the members differ only in the number of CHOH groups in their "tails". The two enzymes only interact with the "head" parts of each of these sugar molecules, so that the chain length of the remainder doesn't enter into the picture and does not create a need for separate enzyme specificities.

The basic idea of chain length variation is that transketolase always transfers two-carbon units, whereas transaldolase always transfers three-carbon units. A curiosity that results from this modus operandi is the occurrence of an eight-carbon sugar [38]. This molecule does not have a role in the pathway, nor does it serve any

other known physiological function, and probably constitutes a byproduct that simply exists at equilibrium.

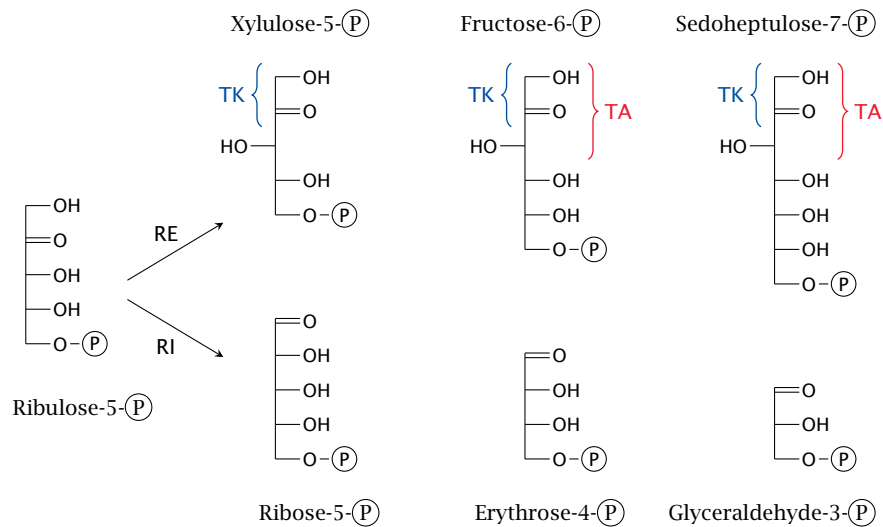

9.2 Imagine three players who hold five chips each, who have been asked to trade chips in amounts of no less than two and no more than three, so that they will end up with six, six and three chips, respectively. How can they do this with the smallest possible number of trades?

9.2.4 The mechanism of transketolase

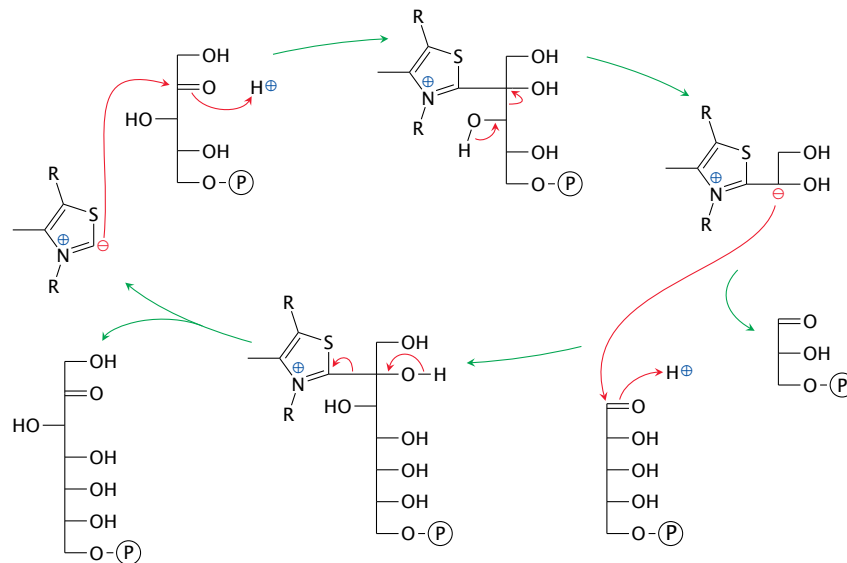

Notes: Transketolase employs the coenzyme thiamine pyrophosphate (TPP), which we encountered before in the pyruvate dehydrogenase E₁ enzyme (slide 5.2.5). As in the pyruvate dehydrogenase reaction, the key function of TPP is to provide a carbanion, and as before, the carbanion reacts covalently with a carbonyl group and cleaves the adjacent C–C bond of the substrate.

It is here, however, that the similarity between transketolase and pyruvate dehydrogenase ends. In the second part of the reaction, another aldose substrate enters and carries the transiently coenzyme-bound C_2 subunit away, regenerating the TPP carbanion.

9.2.5 The mechanism of transaldolase

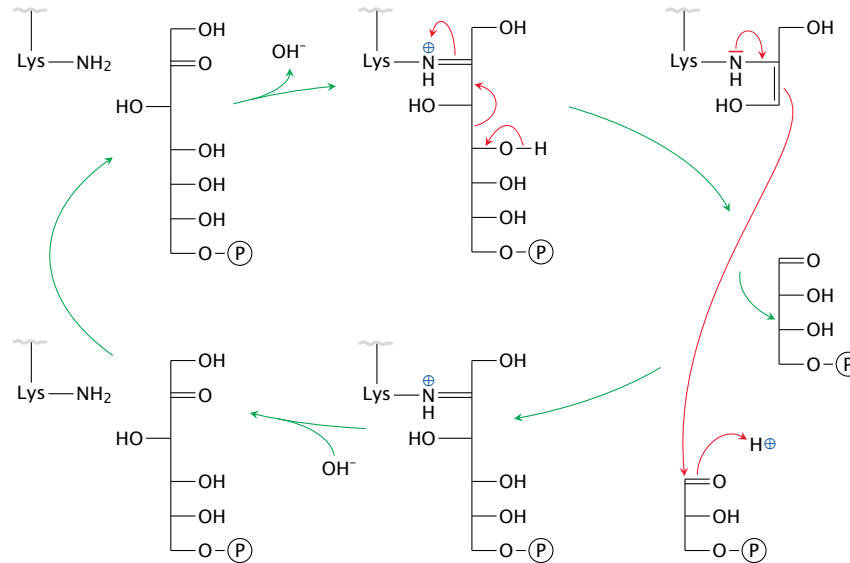

Notes: Transaldolase also forms a covalent intermediate with the fragment of the sugar molecule it transfers, and once more the carbonyl bond serves as the point of attack for cleavage. However, transaldolase cleaves the bond after the second carbon atom, resulting in the transfer of a C_3 unit. The two stages of the reaction are again reversals of each other, with the exception that the two sugar substrates differ in chain length.

Considering their mechanisms, it is clear that both the transketolase and the transaldolase reactions are readily reversible. So are the isomerase reactions that interconvert the various pentose phosphates. The entire pathway therefore can proceed in either direction and bring about the interconversion of pentoses, hexoses, and sugars of other lengths, in any amounts and proportions as needed.



9.3 Discuss similarities and differences between the reaction mechanisms of transaldolase and transketolase.

9.3 The physiological role of NADPH

Our discussion of the HMS pathway is now complete, and we will now have a look at the various metabolic functions of NADPH.

9.3.1 Why do we need both NADH and NADPH?

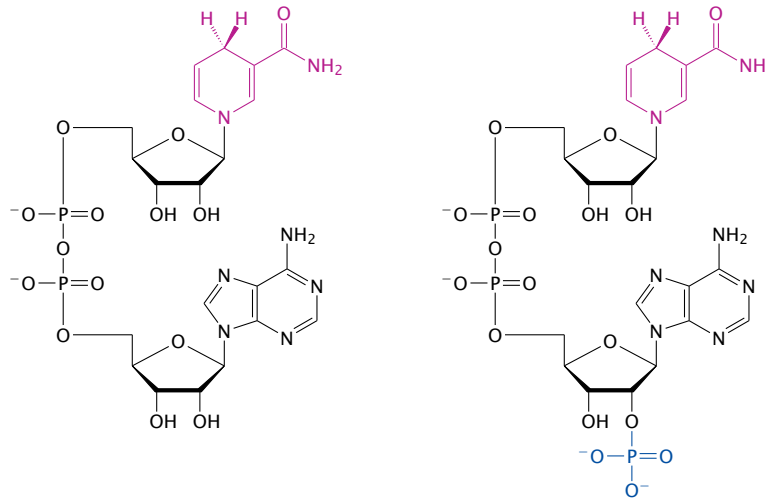

Notes: Why is NADPH needed in addition to NADH? The two coenzymes only differ by one phosphate group, and that group is far away from where the action is: The redox-active group is the pyridine ring in the nicotinamide moiety (highlighted), whereas the extra phosphate in NADP is located on the adenosine moiety at the other end of the molecule.

While the phosphate group does not make any difference to the redox chemistry performed by the two coenzymes,¹ it enables them to interact with separate sets of enzymes. Consider that all enzymes which consume or regenerate NAD^+ will share the same pool of the cosubstrate, and the reaction equilibria of all of them will be affected by the same ratio of oxidized to reduced form, $[\text{NAD}^+]/[\text{NADH}]$.

The extra phosphate group on NADP allows it to interact with another, different set of enzymes. Therefore, because the coenzymes participate in separate sets of equilibria, they can themselves be maintained in different redox states. To use a simile: the two coenzymes are like two different currencies—both are money, but it is possible to tune the cost of borrowing of each separately to different economic objectives. Inside the cell, NAD is mostly oxidized. The ready availability of NAD^+ will help to speed up the oxidative reactions in the TCA cycle and glycolysis. In contrast, NADP is mainly found in the reduced state, which will promote reductive reactions in biosynthesis.

The choice of either NAD or NADP as the cosubstrate will not only affect the turnover rate of a redox reaction but also its free energy (ΔG). According to [39], the $[\text{NADH}]/[\text{NAD}^+]$ ratio in the cytosol is 0.001, while the $[\text{NADPH}]/[\text{NADP}^+]$ ratio is 100. Neglecting the very slight difference in ΔG_0 , the 10^5 times higher relative abundance of NADPH works out to a difference of $\sim 30 \text{ kJ/mol}$ in actual ΔG . This amount of energy is similar to that released by the hydrolysis of ATP to ADP, which is not a coincidence (see next slide).

¹If we use the same concentrations of reduced and oxidized forms in vitro, the difference in their redox potentials is very small; that is, both have virtually the same standard redox potentials.

9.3.2 NADPH generation by malic enzyme

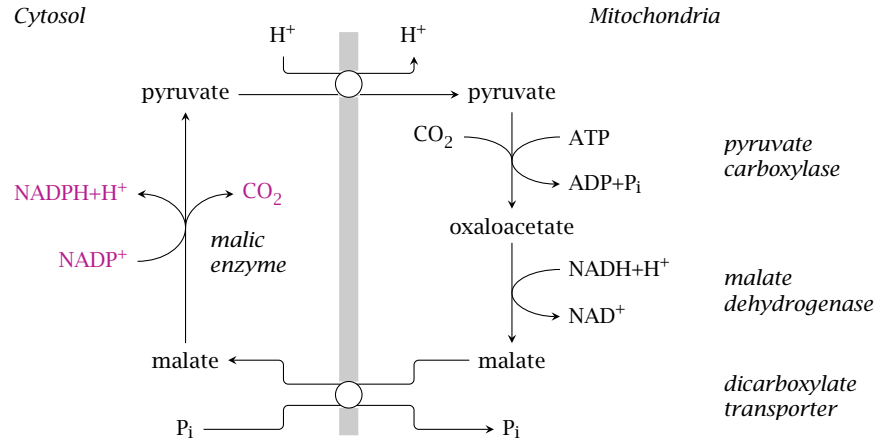

Notes: While the HMS is the major source of NADPH in most tissues, some other pathways contribute to the supply, particularly in tissues that synthesize fatty acids or sterols.

The shuttle shown here reuses most elements of the one that moves oxaloacetate from the mitochondria to the cytosol for gluconeogenesis (see slide 7.4.1, which also shows how to balance the transport of phosphate). However, in the final step of the shuttle considered here, cytosolic malate is not converted to oxaloacetate but is instead decarboxylated by malic enzyme, which generates NADPH; the pyruvate that is left over can reenter the mitochondria.

On the mitochondrial side, the shuttle consumes one equivalent of NADH and ATP each. The ATP drives the carboxylation of pyruvate, which is reverted by malic enzyme. Assuming that malic enzyme can recover the full free energy acquired from ATP during carboxylation and apply it toward the reduction of NADP⁺, the enzyme should indeed be able to raise the ratio of cytosolic NADPH to NADP⁺ to beyond that of NAD by the factor of 10⁵ explicated in slide 9.3.1. While this assumption may be a bit optimistic, it is also not strictly necessary, since the [NADH]/[NAD⁺] ratio is significantly higher in the mitochondria than in the cytosol, which helps push the cycle in the indicated direction. Overall, the participation of ATP in this cycle accounts for the difference in concentration and free energy between NADPH and NADH discussed in the preceding slide.

9.3.3 NADPH generation by transhydrogenase and NADP-linked isocitrate dehydrogenase

Notes: We have already encountered nicotinamide nucleotide transaminase as a source of mitochondrial NADPH before (see slide 6.10.2). From the mitochondria, NADPH can be transported to the cytosol by the concerted action of NADP-dependent isocitrate dehydrogenases on both sides of the membrane and of two mitochondrial carriers, which together manage to exchange isocitrate for α -ketoglutarate across the membrane.

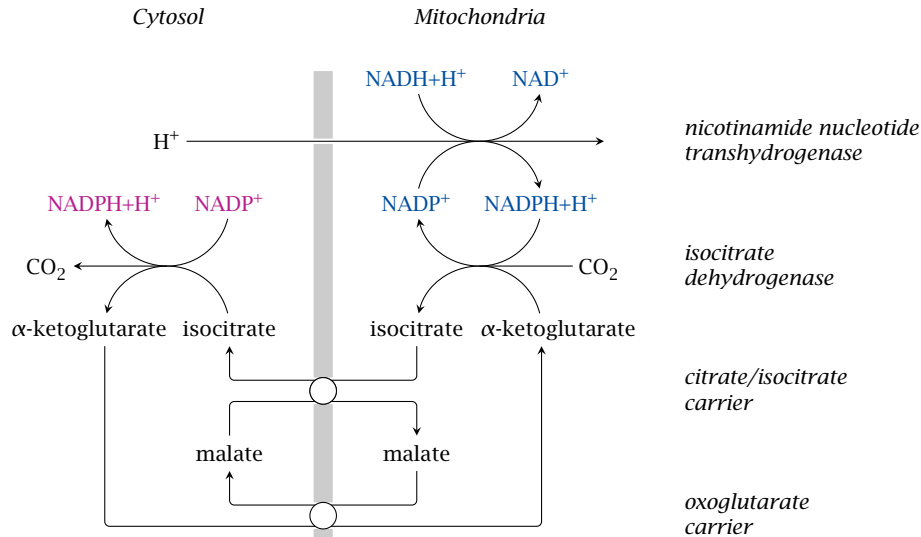

Note that this cycle does not involve the hydrolysis of ATP. The single proton imported by the transhydrogenase does not provide quite the same amount of free energy as ATP, and the question therefore arises how sufficient driving force for the overall process is derived. As far as I can see, the only other contributing factor is the more reduced state of NAD inside the mitochondrion as compared to the cytosol.² It may thus be that this shuttle works only when both the proton-motive force and the mitochondrial NADH are at high levels, while cytosolic NADPH is lowered due to high rates of consumption, such as for example during fatty acid synthesis in fat tissue [40].

 **9.4** Explain how cytosolic NADPH can be regenerated.

9.3.4 Uses of NADPH

1. synthesis of fatty acids and cholesterol
2. fixation of ammonia by glutamate dehydrogenase
3. oxidative metabolism of drugs and poisons by cytochrome P450 enzymes
4. generation of nitric oxide and of reactive oxygen species by phagocytes
5. *scavenging* of reactive oxygen species that form as byproducts of oxygen transport and of the respiratory chain

Notes: The first three topics on this list will be covered in the later chapters on the metabolism of triacylglycerol, cholesterol, amino acids, and drugs, respectively. Here, we will briefly look at the roles of NADPH in the formation of nitric oxide and in the formation and the scavenging of reactive oxygen species.

 **9.5** Summarize the metabolic uses of NADPH.

²The exchange of isocitrate for α -ketoglutarate is electroneutral, and thus does not derive additional drive from the proton-motive force.

9.3.5 Nitric oxide synthase requires NADPH

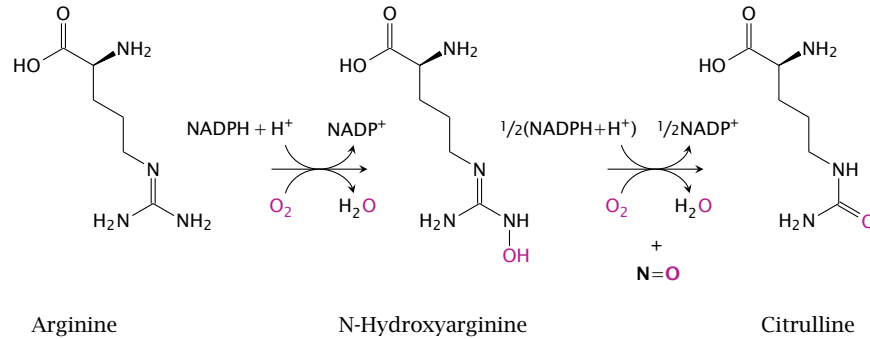

Notes: Nitric oxide is synthesized intracellularly by nitric oxide synthase (NOS). This reaction is rather complex and involves two successive monooxygenase steps. In the first step, arginine is converted to N-hydroxyarginine (NOHA), which is cleaved in the second step to NO and citrulline.

NOS occurs in several variations. Endothelial NOS (eNOS) and neuronal NOS (nNOS) are found in the cell types indicated by their names. Inducible NOS (iNOS) is found mainly in inflammatory cells. All these enzymes are homologous and perform the same reaction, but they differ in their regulatory properties.

9.3.6 Signaling effects of nitric oxide

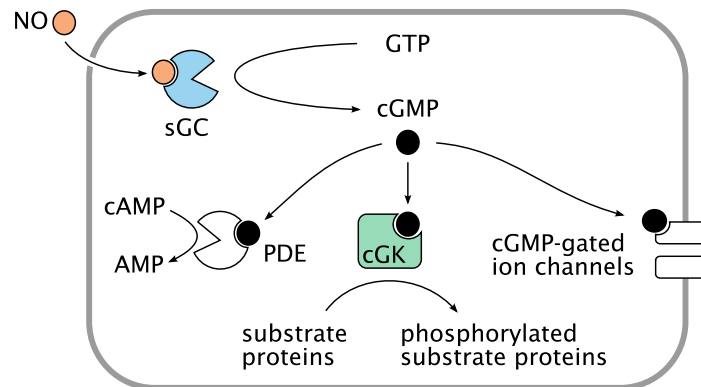

Notes: Nitric oxide produced by NOS diffuses out of the cell of origin, for example a vascular endothelial cell, and then into another one, such as a vascular smooth muscle cell. Within its target cell, NO binds and activates soluble guanylate cyclase (sGC), which then begins to make cyclic GMP (cGMP). Like cAMP, cGMP acts as a second messenger inside the cell.

Also like cAMP, cGMP targets multiple effector molecules. Activation of cGMP-dependent protein kinase (cGK) results in the phosphorylation of various proteins. In vascular smooth muscle, this induces relaxation, which in turn lowers the blood pressure; this is exploited by NO-releasing drugs in the treatment of hypertension. Phosphodiesterase 5 (PDE) is activated by cGMP, too, and begins to degrade both

cAMP and cGMP. Actuation of cyclic nucleotide-gated cation channels affects the membrane potential and the cellular calcium level.

9.3.7 Phagocytes use NADPH to generate reactive oxygen species

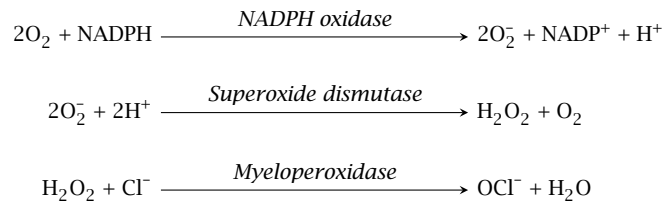
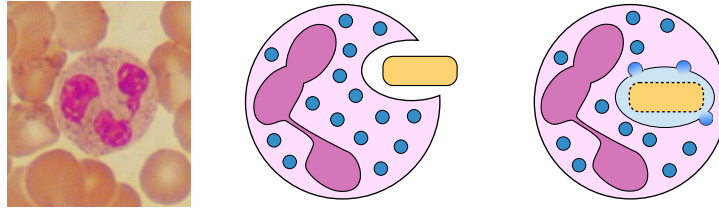

Notes: Neutrophil granulocytes (depicted) and macrophages ingest bacteria and then fuse the endocytotic vacuole with granules that contain various kinds of antimicrobial molecules. Among these, there are several enzymes that produce reactive oxygen species. The first such enzyme is NADPH oxidase, which converts molecular oxygen to superoxide. Subsequently, superoxide dismutase and myeloperoxidase produce H_2O_2 and HOCl . All of these reactive oxygen species (ROS) have powerful antimicrobial activity, and patients with defects in NADPH oxidase or myeloperoxidase are prone to severe bacterial infections.

Superoxide can also combine with nitric oxide to form peroxynitrite, another molecule with strong antimicrobial activity. This is one function of the NO generated in macrophages by inducible nitric oxide synthase (iNOS).



9.6 Explain the role of NADPH in the formation of antimicrobial effector molecules in phagocytes.

9.3.8 Scavenging of reactive oxygen species requires NADPH, too

Notes: Where not needed for immune defense, reactive oxygen species are harmful rather than useful; for example, they can react with non-saturated fatty acyl residues in lipid membranes (see below). Nevertheless, some ROS continually form as byproducts of respiration and also of oxygen transport in erythrocytes, since binding to hemoglobin offers O_2 an opportunity to steal an electron from the heme and turn itself into superoxide.

ROS toxicity is controlled by *glutathione* (G-SH), which is present in the cells at low millimolar concentrations. An important step in the detoxification of ROS is the reduction of hydrogen peroxide (H_2O_2) to water by glutathione peroxidase

(1). In the process, glutathione is oxidized to its disulfide form (G-SS-G). Reduced glutathione is then regenerated at the expense of NADPH by glutathione reductase (2).

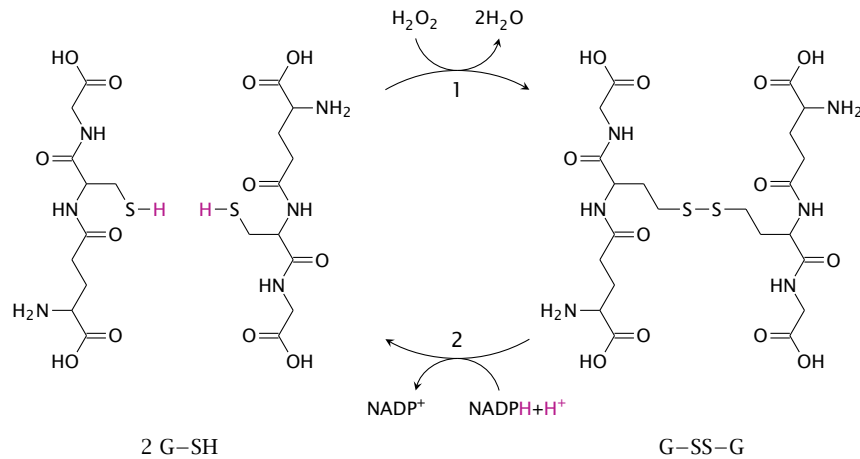

9.4 Glucose-6-phosphate dehydrogenase deficiency

- X-chromosomally encoded—males more severely affected
- most patients are healthy most of the time—hemolytic crises occur upon exposure to drugs or diet components that cause enhanced formation of ROS
- manifest in red blood cells because these cells lack protein synthesis—no replacement of deficient protein molecules
- affords partial protection against malaria—similar to sickle cell anemia and other hemoglobinopathias

Notes: Red blood cells lack mitochondria and thus depend entirely on the hexose monophosphate shunt for NADPH regeneration. Mutations in glucose-6-phosphate dehydrogenase—the first enzyme in the pathway, see section 9.2—that reduce its activity limit the supply of NADPH and, therefore, the capacity of the cell to detoxify reactive oxygen species. ROS that go unscavenged will cause the peroxidation of membrane lipids (see slide 11.6.10 for the mechanism) and destroy the cell. This condition—namely, the occurrence of episodes of hemolytic anemia upon ingestion of ROS-inducing foods or drugs—is called *favism*.

Glucose-6-phosphate dehydrogenase is encoded on the X chromosome, and accordingly males (who have only one X chromosome) are affected the most. However, heterozygous females are not exempt, since, in keeping with the “Mary Lyon hypothesis,” one of the two X chromosomes in females is inactivated randomly early during embryonic development [41]; therefore, in heterozygous females, the bone marrow precursors of the red blood cells will represent a mosaic of intact and deficient genes. Indeed, the observation of such a mosaic in glucose-6-phosphate dehydrogenase deficiency was the first proof of random X chromosome inactivation in humans [42].

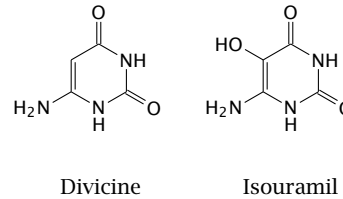
9.4.1 *Vicia faba* and favism

Notes: The word “favism” derives from the Latin name of the broad bean, *Vicia faba*. Broad beans contain several pyrimidine derivatives such as isouramil and divicine that can catalyze the formation of ROS through redox cycling, which is explained in the next slide.

9.4.2 Redox cycling of isouramil

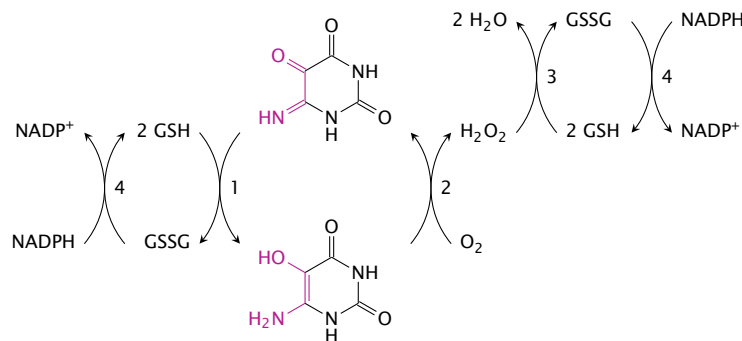

Notes: This scheme outlines the redox cycle induced by isouramil. Reactions (1) and (2) occur spontaneously, without any need for enzymatic catalysis. The H_2O_2 formed in reaction (2) is reduced by glutathione peroxidase (3). The glutathione disulfide formed in reactions (1) and (3) is reduced at the expense of NADPH in reaction (4) by glutathione reductase. Therefore, this redox cycle consumes four equivalents of reduced glutathione (GSH) in every full turn. Divicine and some other substances contained in broad beans cause analogous cycles.

9.4.3 Malaria parasites detoxify heme by crystallization

Notes: Malaria parasites multiply inside erythrocytes, where they feed on hemoglobin. They digest the protein (globin) but leave behind the heme, which is toxic to them because it catalyzes the formation of reactive oxygen species. To reduce the toxicity of heme, the parasites induce its crystallization; the crystalline deposits are visible inside the infected cells as brownish so-called malaria pigment. The parasites also produce several heme-binding proteins to aid in the detoxification.

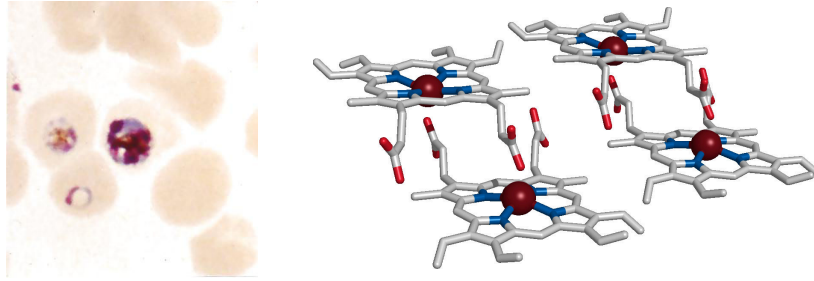

Another factor that may contribute to the protection of the parasites from heme toxicity is the red cells' own glutathione-dependent ROS scavenging pathway. This provides a plausible explanation for the observation that glucose-6-phosphate dehydrogenase deficiency affords partial protection from malaria, which has led to the enrichment of this enzyme defect in the human gene pool in endemic malaria areas.

9.4.4 Primaquine and glucose-6-phosphate dehydrogenase deficiency

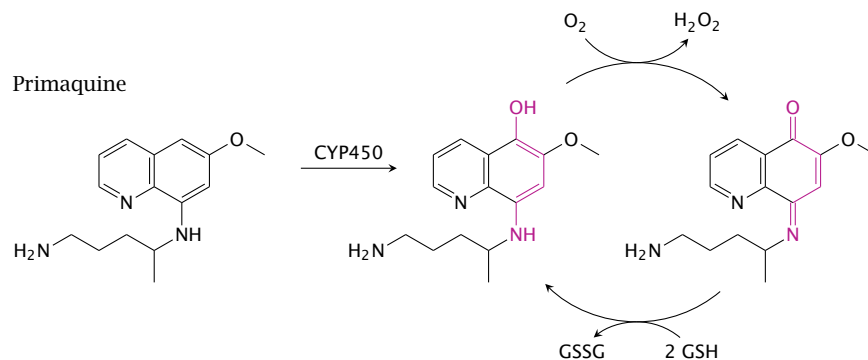

Notes: The higher prevalence of glucose-6-phosphate dehydrogenase deficiency in people from traditionally malaria-infested areas is something to keep in mind when treating malaria patients with primaquine. The drug is hydroxylated to 5-hydroxyprimaquine by cytochrome P450 enzymes, and the metabolite will set up a redox cycle that is analogous to the isouramil-based one shown in slide 9.4.2 (but is only shown partially in this slide). Primaquine thus may induce hemolytic crises in these patients. Several other drugs can do the same.

 **9.7** Explain the causation and significance of favism.

9.5 Answers to practice questions

9.1: NADPH regeneration, as well as synthesis and utilization of ribose-5-phosphate.

9.2: They can do this by adopting the trading scheme of the hexose monophosphate shunt. Transketolase corresponds to a two chip trade, transaldolase to a three chip trade.

9.3: Both enzymes employ covalent catalysis and initiate the reaction by nucleophilic attack on their substrates' carbonyl groups, and both reactions are reversible. The enzymes differ in the nature of their nucleophiles (thiamine pyrophosphate with transketolase, a

lysyl residue with transaldolase) and in the position of bond cleavage/formation relative to the carbonyl groups.

9.4: Aside from the hexose monophosphate shunt, cytosolic NADPH can be regenerated using mitochondrial reducing power. In one such pathway, mitochondrial malate is translocated to the cytosol and converted to pyruvate by malic enzyme, which yields NADPH; the pyruvate can be converted back to malate by pyruvate carboxylase and malate dehydrogenase in the mitochondria.

Another pathway involves isocitrate, for which there is an NADP-dependent dehydrogenase both in the cytosol and the mitochondria. A cycle propelled by nicotinamide nucleotide transhydrogenase effects the formation of isocitrate in the mitochondria and its dehydrogenation in the cytosol.

9.5: See list in slide 9.3.4.

9.6: NADPH is used by NADPH oxidase to reduce O_2 to superoxide, which can then give rise to H_2O_2 and HOCl through the actions of superoxide dismutase and myeloperoxidase. Superoxide can react with NO, whose formation by nitric oxide synthase also requires NADPH, to peroxynitrite. All these molecules have antimicrobial activity.

9.7: Favism is caused by a genetic defect of glucose-6-phosphate dehydrogenase. This defect limits the capacity of erythrocytes to regenerate reduced glutathione.

Broad beans contain isouramil and several similar compounds that cause redox cycles. In such a redox cycle, molecular oxygen is reduced to hydrogen peroxide, which in turn is reduced to water, at a total expense of four equivalents of reduced glutathione. If glucose-6-phosphate dehydrogenase deficiency patients ingest broad beans, the limited supply of reduced glutathione causes hydrogen peroxide to accumulate. This results in lipid peroxidation within the cell membrane and then hemolysis.

Similar redox cycles can also arise from certain drugs and drug metabolites, and the application of such drugs must be avoided in patients with favism.

Chapter 10

Triacylglycerol metabolism

10.1 Overview

Various types of lipids occur in the human body, namely 1) triacylglycerol, 2) cholesterol, and 3) polar lipids, which include phospholipids, glycolipids and sphingolipids. This chapter will focus on triacylglycerol; cholesterol will be covered in a separate chapter. The metabolism of polar lipids will not be covered systematically.

In contrast to polar lipids and cholesterol, which are found in the membranes of every cell, triacylglycerol is concentrated mostly in adipose (fat) tissue; minor amounts of triacylglycerol occur in other cell types, such as liver epithelia and skeletal muscle fibers. Yet, overall, triacylglycerol is the most abundant lipid species, and the only one with an important role in energy metabolism.

Triacylglycerol occurs in human metabolism in two roles, namely 1) as a foodstuff, which accounts for a significant fraction of our caloric intake, and 2) as a store of metabolic energy. This store can be replenished using dietary triacylglycerol or through endogenous synthesis from carbohydrates or proteins.

10.1.1 Foodstuffs and their energy contents

Notes: The amount of energy stored per gram of tissue is far higher in fat than in any other tissue, for two reasons:

1. One gram of triacylglycerol itself contains more than twice as many calories as one gram of carbohydrates or protein. This is simply because triacylglycerol contains much less oxygen than carbohydrates, in which oxygen contributes half the mass but essentially no metabolic energy. Similarly, the oxygen, nitrogen and sulfur contained in protein detract from its energy density.

Foodstuff	Energy (kcal/g)
protein	4
carbohydrates	4
triacylglycerol	9
alcohol	7

2. Triacylglycerol in fat cells coalesces to droplets that are entirely free of water. In contrast, protein and carbohydrates, including glycogen, always remain hydrated, which further diminishes the density of energy storage.

10.1.2 Carbon pools in carbohydrate and fat metabolism

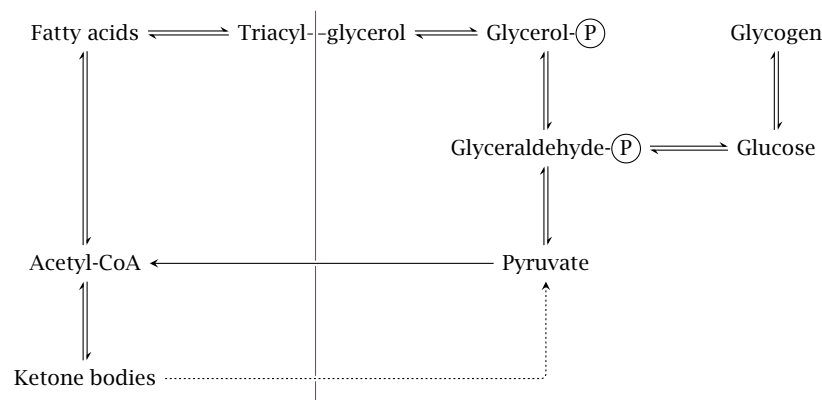

Notes: Because of its high energy density, it makes sense that most of the excess glucose or protein is converted to fat, while only a limited fraction is stored as glycogen. There is, however, one limitation to the usefulness of triacylglycerol: the conversion of carbohydrate or protein to fatty acids via acetyl-CoA is more or less a one-way street. Carbon stored as triacylglycerol is, for the most part, confined to the limited scope of pathways on the left of the red line in this slide. Within this pool, the carbon may be turned into free fatty acids, which can serve as fuel for heart and skeletal muscle, or into ketone bodies, which can supply energy to several more organs, including the brain. However, it can no longer be turned back into glucose; or at least not efficiently so, since the dotted “bootlegger’s pathway” that leads from ketone bodies to pyruvate (and from there again to glucose) has limited capacity (see slide 10.4.3).

Because of the restricted metabolic scope of triacylglycerol, we cannot rely exclusively on fat degradation in a catabolic situation. Once glycogen is used up, continued fasting will deplete not only stored fat but also protein, most notably in skeletal muscle, which is necessary to maintain a sufficient supply of glucose via gluconeogenesis.



10.1 Explain the advantages and disadvantages of triacylglycerol and glycogen as stores of metabolic energy.

10.2 Digestion and uptake of dietary triacylglycerol

As discussed in the first chapter (slide 1.6.8), dietary triacylglycerol undergoes hydrolysis in the digestive tract. The main products of hydrolysis are monoacylglycerol and free fatty acids.

10.2.1 Triacylglycerol and its cleavage products

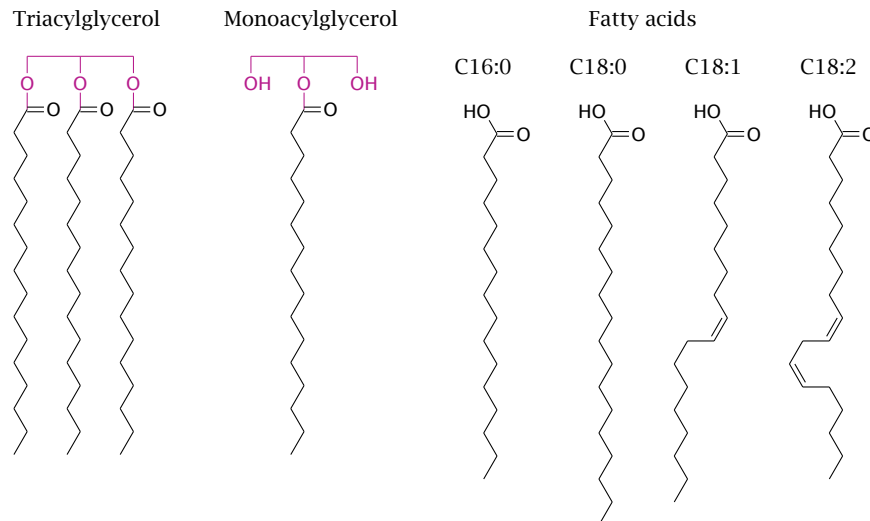

Notes: The fatty acids found in natural fats vary both in chain length and in the number of double bonds. The slide shows the four most abundant species; from the left to the right, their trivial names are palmitate, stearate, oleate, and linoleate. Other chain lengths and degrees of unsaturation occur.¹ A minor fraction of dietary fatty acids, mostly from plants, contain less than 12 carbon atoms; these so-called medium-chain fatty acids have some peculiar metabolic properties that make them therapeutically useful in certain diseases (slide 10.3.9).

10.2.2 Solubilization of fat by detergents

Notes: Detergents are amphiphilic molecules that are freely soluble in water at low concentrations but reversibly aggregate into *micelles* at higher ones. When mixed with fat, monomeric detergent molecules penetrate the fat particles and break them up into mixed micelles; in this form, the fat becomes amenable to cleavage by lipases. The fatty acids released by enzymatic hydrolysis act as detergents themselves and will aid in the solubilization of remaining fat during digestion.²

¹Linolenic acid looks like linoleic acid but has an additional double bond between the third and the fourth carbon from the far end. Such ω 3-fatty acids are required but cannot be synthesized in human metabolism; they are therefore *essential*.

²Curd soap is prepared simply by alkaline hydrolysis of fat; it consists of the sodium salts of the fatty acids released.

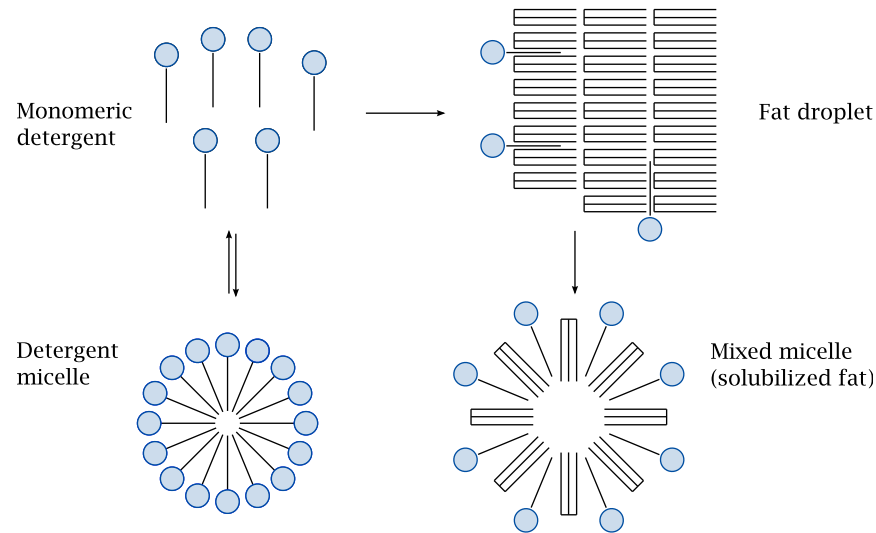

The critical micellar concentration (CMC) of a detergent is the threshold above which any additional detergent will coalesce into micelles. Since only the monomeric detergent molecules can interact with fat, it follows that detergents with higher CMC values will solubilize fat more rapidly. Bile acids have particularly high CMC values and solubilize fat very swiftly.³

While most of the dietary triacylglycerol is hydrolyzed by pancreatic triacylglycerol lipase in the small intestine, fat digestion is already initiated by *gastric* lipase, which is released by the mucous membrane of the stomach [43]. In vitro, this enzyme can be activated by bile acids also, but since these are absent from the stomach, the question arises what molecules might serve as auxiliary solubilizing agents for gastric lipase in vivo. Plausible candidates are dietary proteins and phospholipids [44].

10.2.3 Uptake and re-packaging of digested fat in the small intestine

Notes: After solubilization and lipase digestion, monoacylglycerol and free fatty acids are taken up by epithelial cells in the mucous membrane of the small intestine. What happens to them once inside is somewhat surprising: they are immediately converted back to triacylglycerol. This involves the transient activation of fatty acids to acyl-CoA (see slide 10.3.1) at the expense of ATP.⁴ The newly formed fat is then combined with protein molecules called *apolipoproteins* into lipoprotein particles, such that the proteins form a hydrophilic shell around the lipid core. Some phospholipids are included as well and complete the hydrophilic shell.

³It is this property that makes them useful in treating laundry also.

⁴Considering that the resynthesis immediately after cleavage is energetically costly, one might wonder why these two steps are necessary; it might seem more economical to absorb fat molecules without cleavage. My tentative interpretation is that the complete dispersal and degradation of triglycerides serves as a security screen. If droplets of ingested fat were allowed to enter the system wholesale, a lot of fat-soluble, potentially toxic compounds dissolved in them could sneak into the system unchecked.

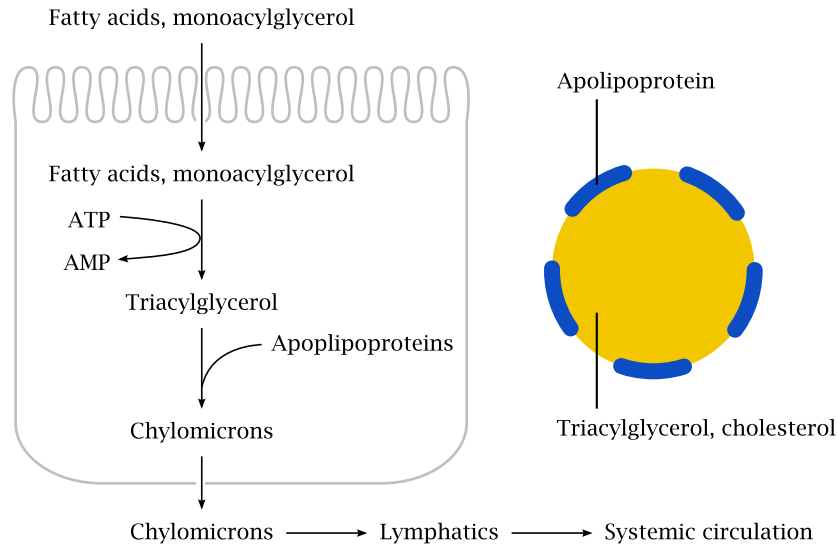

Lipoproteins occur in various subtypes (see slide 11.4.2). The specific type formed at this stage, the *chylomicrons*, are the largest of all lipoproteins, with a molecular mass of up to 10^{10} Dalton, a diameter up to $1\ \mu\text{m}$, and approximately 10^7 molecules of triacylglycerol. The chylomicrons also transport dietary cholesterol; this is discussed in slide 11.4.3.

Like glucose and other solutes taken up from the gut, the chylomicrons are released into the extracellular space at the basolateral side of the intestinal epithelia. However, unlike those solutes, the chylomicrons are *not* drained toward the liver via the portal vein, but instead are drained via the lymphatics. This is explained in the next two slides.

10.2.4 The lymphatics drain excess fluid from the interstitial space

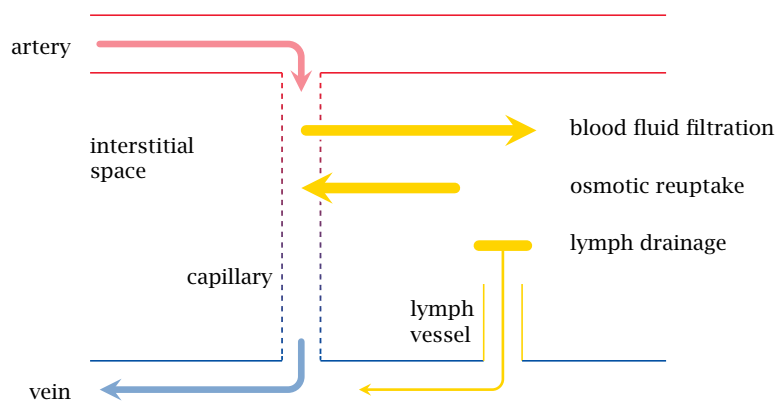

Notes: This slide and the next one introduce a bit of background to explain how chylomicrons are transported from the intestine to the systemic circulation.

The capillaries of the blood circulation are porous, and the hydrostatic pressure within them drives the filtration of plasma fluid into the interstitial space. Since the pores in the capillary walls are small, filtration is limited to water and

small solutes. Albumin and other plasma proteins are *not* filtered and therefore maintain an osmotic pressure gradient that opposes and mostly compensates for hydrostatic filtration. The fraction of the filtrate that is not recovered through osmosis is drained by lymphatic vessels and then back to the venous side of the systemic circulation.⁵

10.2.5 Chylomicrons are drained from the intestine through the lymphatics, bypassing the liver

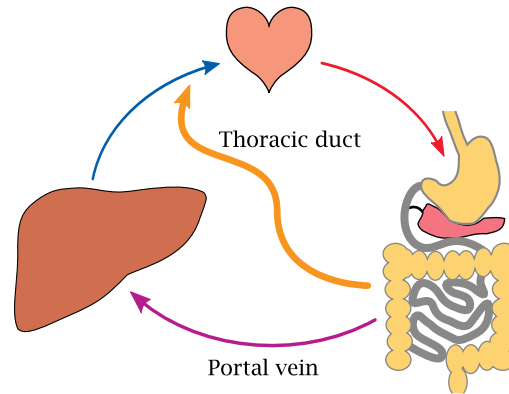

Notes: Just as plasma proteins are excluded from diffusing out of capillaries, the chylomicrons are excluded from diffusing into them. Chylomicrons thus cannot enter the circulation directly and must instead be drained through the lymphatic system. The *thoracic duct*, which is the major effluent of the entire lymphatic system, joins one of the major veins just a short distance upstream of the heart, but downstream of the liver. Therefore, unlike glucose and other small molecules that are taken up in the intestines, chylomicrons bypass the portal circulation and the liver. They will, however, reach the liver via the systemic circulation at a later stage (see next slide).

10.2.6 Lipoprotein lipase extracts triacylglycerol from chylomicrons

Notes: Once the chylomicrons have entered the circulation, the capillary wall barrier must again be overcome in the delivery of triacylglycerol to extravascular cells. This is accomplished with the help of *lipoprotein lipase*, which is located on the endothelial surface. It binds the chylomicrons and extracts triacylglycerol from them, which it then cleaves again to fatty acids and glycerol. These small molecules can cross the endothelial barrier by diffusion and reach the cells in the surrounding tissue.

⁵This slow but steady flow of fluid through all tissues is also important for immune surveillance: when a lymph vessel traverses a lymph node, the resident macrophages and lymphocytes sample the lymph fluid for unusual antigens that would signal an infection upstream, and will promptly mount an immune response to such antigens.

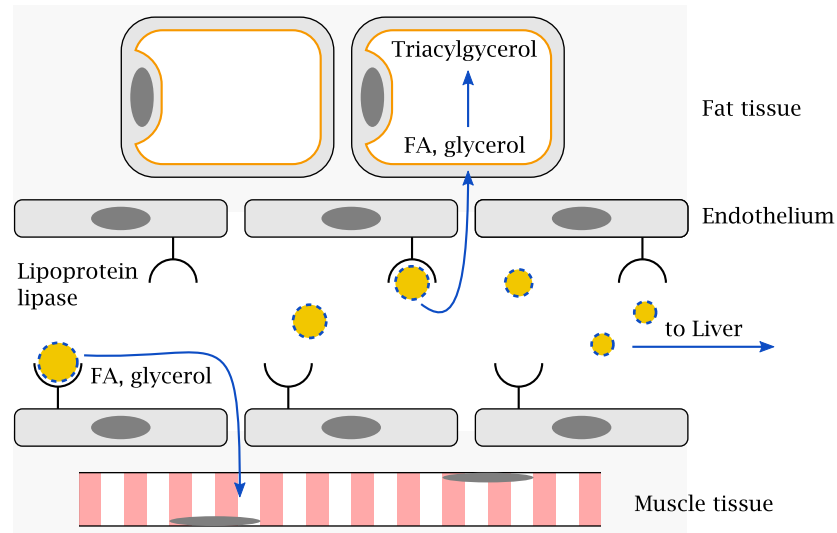

In adipose cells, the fatty acids are combined with glycerol yet again for storage. In other cell types, most notably muscle cells, they may either be stored or degraded directly to acetyl-CoA, which is then consumed in the TCA cycle and the respiratory chain. The remnants of chylomicrons, depleted of most of their triacylglycerol, are captured by the liver, endocytosed, and degraded. The cholesterol and remaining fat released in the process is either utilized in the liver or repackaged into other lipoprotein particles.⁶

 **10.2** Describe the processes involved in triacylglycerol digestion, absorption and storage.

10.3 Utilization of fatty acids: β -oxidation

As briefly mentioned before, the utilization of fatty acids occurs by way of conversion to acetyl-CoA, which is accomplished in β -oxidation. This pathway runs in the mitochondria, so the first task after cellular uptake of the fatty acid molecule is to get it into the mitochondrion.

10.3.1 Two activated forms of fatty acids

Notes: Fatty acids are initially activated to fatty acyl-CoA in the cytosol. This is also the form in which they enter degradation by β -oxidation. However, during transport, the CoA-moiety is transiently replaced by *carnitine*. This slide shows the structures of both the CoA- and the carnitine-activated forms; the entire transport process is outlined in the next one.

⁶At this point, we might again wonder why the transport of fat from the intestines to other tissues is so complicated—it might seem easier to do just pour the free fatty acids into the bloodstream. One reason is that free fatty acids are *toxic*. As mentioned before, they are detergents—and detergents dissolve cell membranes. (Interestingly, the membranes of the intestinal cells withstand very high concentrations of bile and fatty acids! They manage this due to their high content of ceramide, which is also found in the keratin of the skin.) However, as we will see later, fatty acids with shorter acyl chains are indeed transported in free form.

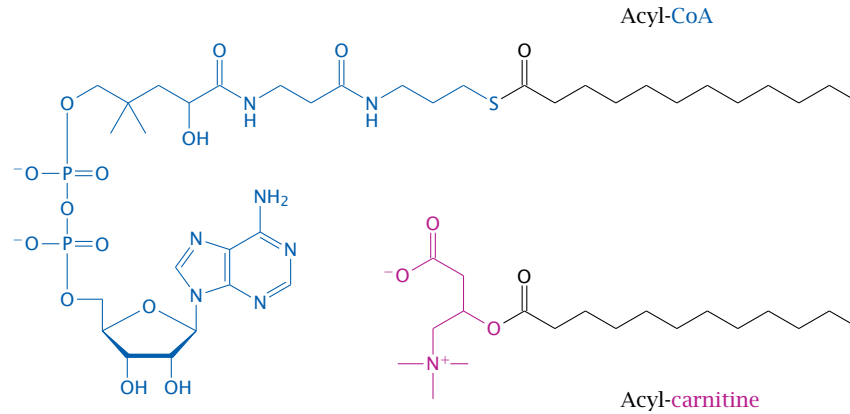

10.3.2 Activation of fatty acids and transport to the mitochondrion

Notes: Fatty acids are activated in the cytosol to acyl-CoA by acyl thiokinase, also known as acyl-CoA synthetase. After transport across the outer mitochondrial membrane, the acyl group is transferred to carnitine by carnitine acyltransferase. Exchange for free carnitine transports the acylcarnitine molecule into the mitochondrial matrix, where carnitine is replaced again with coenzyme A by a second acyl transferase.

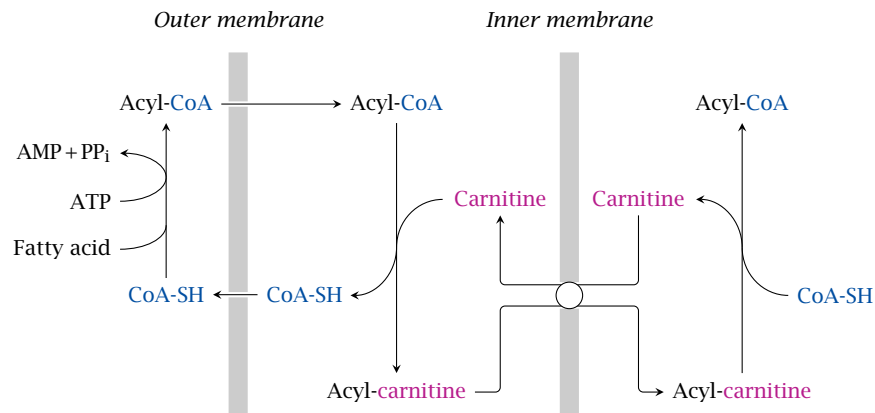

One unusual aspect of this transport process is that the energy of the thioester bond in acyl-CoA seems to be sufficiently well preserved in the ester bond of acyl-carnitine to allow the exchange reaction to be reversed inside the mitochondrion. Carboxyl ester bonds don't usually have a sufficiently high energy content for that. I once stumbled upon a theoretical paper explaining why carnitine is special in this regard, but it went straight over my head, and I therefore cannot give you an explanation.

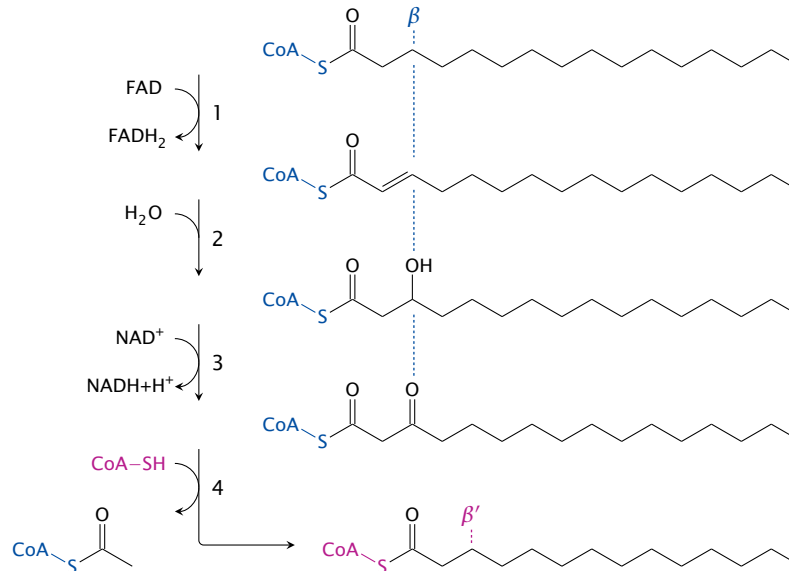
10.3.3 Reactions in β -oxidation

Notes: The term β -oxidation refers to the Greek lettering of the carbons in organic molecules: the α carbon is right beside a functional group, and the β carbon is the next one. It is at the second carbon from the thioester, then, where the action is in β -oxidation. The reactions are as follows:

1. The fatty acyl-CoA molecule is first dehydrogenated between the α and the β carbon atoms by acyl-CoA dehydrogenase. FAD accepts the hydrogen abstracted and is reduced to FADH_2 . This yields 2-trans-enoyl-CoA .
2. The trans double bond just created is hydrated—that is, water is added to it—by enoyl-CoA hydratase, which yields hydroxyacyl-CoA. The α carbon is now once more fully reduced.
3. The β -hydroxyl group is converted to a keto group by hydroxyacyl-CoA dehydrogenase. NAD^+ accepts the hydrogen. The product is $\beta\text{-ketoacyl-CoA}$.
4. Thiolase introduces a new molecule of coenzyme A to cleave the $\beta\text{-ketoacyl-CoA}$, which releases acetyl-CoA and a new, shortened acyl-CoA that enters the next cycle of β -oxidation.

The process is repeated until the fatty acid is completely broken down. In the case of acyl chains with even numbers of carbons, this will yield acetyl-CoA only, whereas those with odd numbers of carbons will yield one molecule of propionyl-CoA in the final thiolase step. There is a special pathway to take care of the propionyl-CoA, which is surprisingly complicated (see slide 10.3.6).



10.3 Draw the reactions in β -oxidation.

10.3.4 Shared reaction patterns in β -oxidation and TCA cycle

Enzyme	Reaction	Cosubstrate	TCA cycle pendant
acyl-CoA dehydrogenase	dehydrogenation of $\text{CH}_2\text{-CH}_2$ bond	FAD	succinate dehydrogenase
enoyl-CoA hydratase	hydration of $\text{CH}_2=\text{CH}_2$ bond	H_2O	fumarase
hydroxyacyl-CoA dehydrogenase	dehydrogenation of CH-OH bond	NAD^+	malate dehydrogenase

Notes: You may have noticed the similarities of the enzyme reactions discussed above to some others we have seen before. In the first three steps, the similarities to reactions from the citric acid cycle are quite straightforward. Also notice the consistent use of redox coenzymes (NAD^+ and FAD) in both pathways: Wherever a CH-OH bond is dehydrogenated, NAD^+ is employed as the cosubstrate,⁷ while FAD is used where dehydrogenation occurs across a CH-CH bond.

10.3.5 The reaction mechanism of thiolase

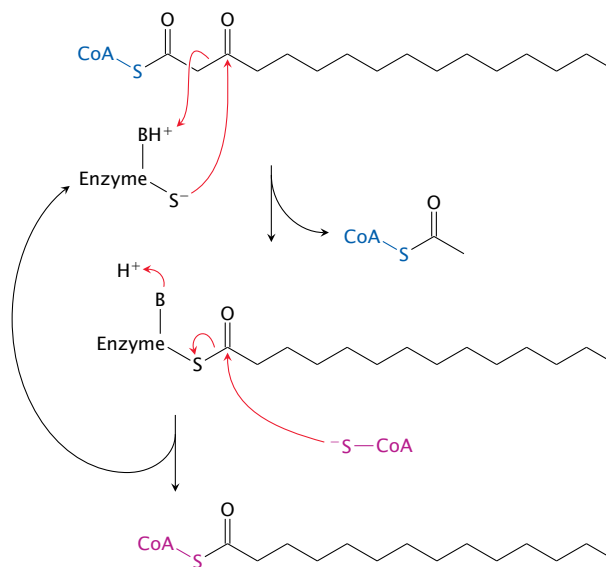

Notes: The thiolase mechanism does not have a closely analogous precedent among the reactions we have seen so far. However, if we look at the individual steps of the thiolase reaction, we can still recognize some familiar features:

⁷This also holds in other pathways and for CH-NH bonds. The only exception I'm aware of is the dehydrogenation of glycerophosphate in the glycerophosphate shuttle.

1. The nucleophilic attack of a cysteine thiolate in the active site on a carbonyl group in the substrate yields a covalent intermediate. This also happens with glyceraldehyde-3-phosphate dehydrogenase (see slide 3.3.5).

2. Acid-base catalysis breaks a C–C bond adjacent to the carbonyl bond. Note that the thiolase reaction is reversible. Making of a C–C bond adjacent to the carbonyl group by acid-base catalysis then occurs in the reverse reaction, which we have seen before with citrate synthase (slide 5.4.2).

3. The creation of one thioester at the expense of another occurs in the second step of the pyruvate dehydrogenase reaction (see slide 5.2.7).

10.3.6 Utilization of propionate

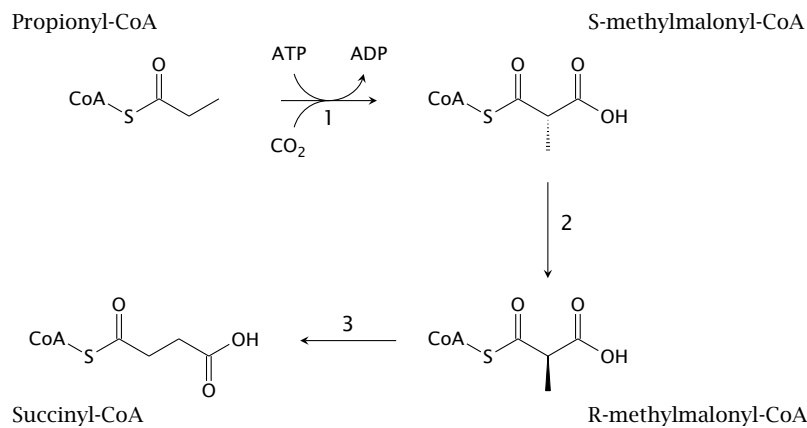

Notes: Fatty acids with odd numbers of carbon atoms yield one molecule of propionyl-CoA as the final degradation product. This metabolite has a rather elaborate degradative pathway:

1. Initially, propionyl-CoA is converted to *S*-methylmalonyl-CoA by propionyl-CoA carboxylase. This reaction uses CO_2 and ATP, with biotin serving as a coenzyme; the mechanism resembles that of pyruvate carboxylase (slide 7.2.4).

2. *S*-methylmalonyl-CoA is converted to its enantiomer *R*-methylmalonyl-CoA by methylmalonyl-CoA racemase.

3. Finally, one carboxyl group is transplanted within the molecule by methylmalonyl-CoA mutase to yield succinyl-CoA. This is a frighteningly complex reaction; we will skip the gory details and just note that it requires vitamin B_{12} , in the form of adenosylcobalamin, as a coenzyme. When this vitamin is lacking, methylmalonyl-CoA backs up and is hydrolyzed to free methylmalonate, which may inhibit gluconeogenesis (see slide 7.4.1).

Note that succinyl-CoA is a citric acid cycle intermediate. It can therefore enter gluconeogenesis (see slide 7.1), so that propionyl-CoA is an exception to the rule that carbon from fatty acids cannot be used for gluconeogenesis. However, since fatty acids with odd numbers of carbons amount to a small fraction of all fatty acids, this exception is not quantitatively very important.



10.4 If we assume that oxidation of NADH yields 3 equivalents of ATP and oxidation of FADH₂ yields 2, how many equivalents of ATP does the complete oxidation of one molecule of palmitoyl-CoA provide?

10.3.7 Organ relationships in triacylglycerol utilization

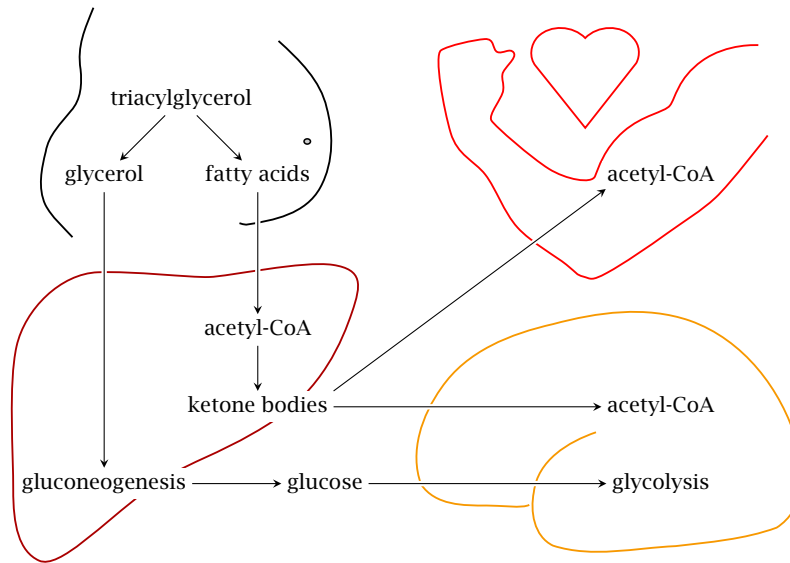

Notes: When triacylglycerol is mobilized from the fat tissue, its hydrolysis to free fatty acids and glycerol is initiated by an enzyme named *hormone-sensitive lipase*. This lipase is stimulated downstream of glucagon and epinephrine, the antagonist hormones of insulin. As seen before in carbohydrate metabolism (slides 7.5.4 and 8.4.2), the two hormones activate adenylate cyclase and protein kinase A. The fatty acids produced by the lipase are released into the bloodstream, where they bind to albumin for transport. The fatty acids can be utilized in two different ways:

1. Directly, that is, they are taken up by the energy-requiring target tissue and degraded by β -oxidation. We noted above that β -oxidation is preceded by the translocation to the mitochondrion, which requires carnitine. About 95% of all carnitine is found in skeletal muscle,⁸ which implies that muscle tissue is the major client for direct utilization. The heart muscle cells also consume fatty acids through β -oxidation.

2. Indirectly, after initial conversion to *ketone bodies* in the liver. This term comprises two small organic acids, acetoacetate and β -hydroxybutyrate, as well as acetone. The brain, which in the well-fed state only utilizes glucose for ATP regeneration, is able to replace up to 50% of its usual glucose consumption with ketone bodies during starvation. The brain is responsible for approximately 20% of our total energy consumption at rest, and therefore is a major consumer of ketone bodies. Other major clients are the heart and skeletal muscle.

⁸The word *carnis* is Latin for meat—as in chili con carne.

The second cleavage product of fat, glycerol, is released into the bloodstream and picked up by the liver as well. It is phosphorylated by glycerol kinase to glycerophosphate. As we have seen before (slide 6.9.3), this metabolite can be dehydrogenated to dihydroxyacetone phosphate, which may enter gluconeogenesis. Glycerol released from fat constitutes a minor source of glucose in times of starvation.

The pattern of fat usage sketched out here holds for the bulk of all adipose tissue, which is white. An exception from this pattern is brown fat tissue, which is covered in the next slide.

10.3.8 Brown fat tissue

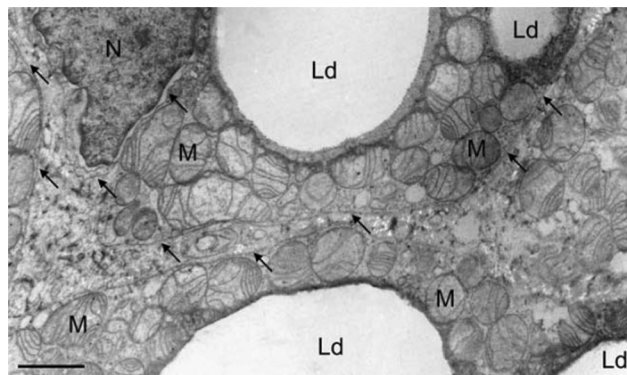

Notes: Cells in white fat tissue owe their color to the fact that they contain little else than large, single triacylglycerol droplets. Intensely colored tissues, other than the pigment cells of the skin, are rich in heme or cytochromes. This is also the case with brown fat tissue. In addition to multiple small lipid droplets (Ld), they contain an abundance of mitochondria (M), which in turn are rich in cytochromes. The mitochondria in this particular tissue also contain a high amount of an uncoupling protein (slide 6.3.1) called *thermogenin*.

In contrast to white fat cells, brown fat cells do not release fatty acids into the circulation but instead carry out β -oxidation themselves. The accumulated hydrogen is oxidized in the respiratory chain. The resulting proton-motive force is not used for ATP synthesis, but is instead simply dissipated as heat—the purpose of brown fat is heat production.

There is little brown fat in adult humans or most other adult mammals. However, there is a substantial amount in newborns, who because of their higher surface-to-volume ratio, and their helplessness, are at greater risk of hypothermia. Brown fat is also found in hibernating animal species such as groundhog, which need it to reheat themselves to operating temperature during arousal from hibernation.

10.3.9 Medium-chain fatty acids

- contain less than 12 carbon atoms
- low content in most foods, but relatively high (10–15%) in palm seed and coconut oil, from which they are industrially prepared
- triglycerides with medium chains are more soluble and more rapidly hydrolyzed by gastric and pancreatic lipase
- not efficiently re-esterified inside intestinal cells; systemic uptake mostly as free fatty acids
- reach mitochondria by diffusion, without prior activation to acyl-CoA and acyl-carnitine

Notes: Medium-chain fatty acids (MCFA) are not a major constituent of our regular diet, nor are they required; however, they can be useful in patients whose ability to digest or absorb regular fats is compromised. They are more readily hydrolyzed by enzymes, in particular by gastric lipase, which usually plays a minor role only in the digestion of triacylglycerol with regular, longer acyl chains.

Gastric lipase continues to be secreted, even at increased levels [45], when pancreatic lipase is lacking due to exocrine pancreas insufficiency. Therefore, MCFA triglycerides can still be processed in this situation. They are used in the dietary treatment of such patients and also of those with other types of fat maldigestion and malabsorption.



10.5 Explain how fatty acids are transported to the mitochondria for β -oxidation.

10.4 Ketone body metabolism

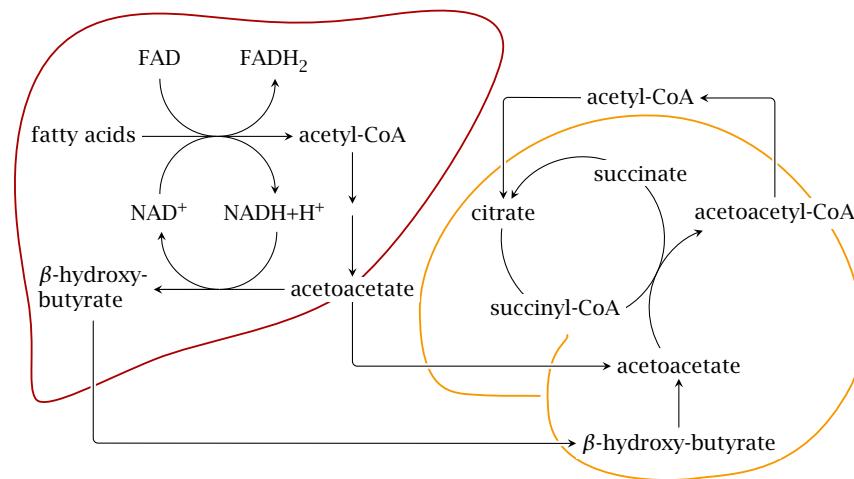

Notes: The key idea of ketone body metabolism is to convert free fatty acids into more water-soluble substrates that are easier to transport and to metabolize. This scheme gives an overview of organ relationships and pathways; note that the reactions are not stoichiometrically balanced.

Ketone bodies are formed mostly in the liver. As stated earlier, the first stage of ketogenesis consists in β -oxidation. The resulting acetyl-CoA is turned into acetoacetate along the pathway detailed in the next slide. The subsequent reduction of acetoacetate to β -hydroxybutyrate allows the liver to dispose of some of the surplus hydrogen that accumulates during β -oxidation. Both acetoacetate and β -hydroxybutyrate are released into the circulation.

Utilization of ketone bodies in the brain, muscle and other tissues is quite straightforward. β -Hydroxybutyrate is dehydrogenated again to acetoacetate, which steals coenzyme A from succinyl-CoA to become acetoacetyl-CoA. Thiolase then cleaves acetoacetyl-CoA to two molecules of acetyl-CoA, which enter the TCA cycle.

10.4.1 Synthesis of acetoacetate and β -hydroxybutyrate

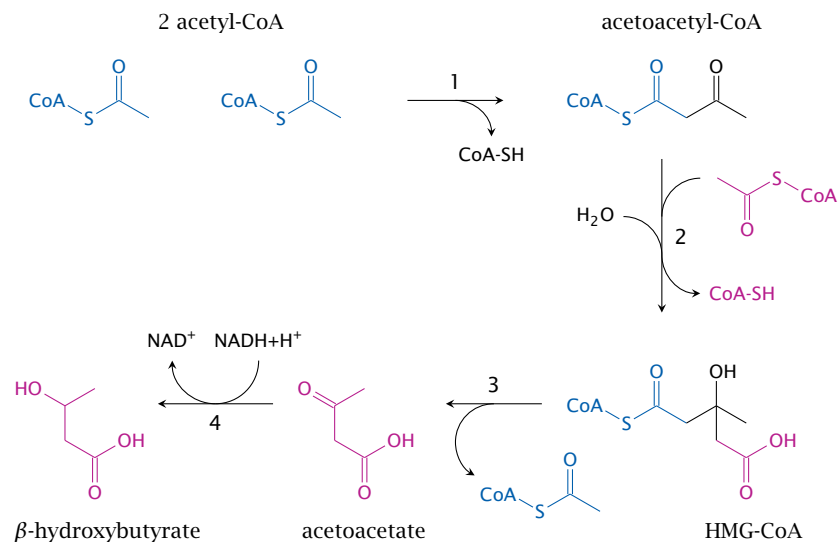

Notes: This slide details the mitochondrial pathway that converts acetyl-CoA to ketone bodies. It involves the following steps:

1. formation of acetoacetyl-CoA from two molecules of acetyl-CoA by thiolase. This step is the reversal of the final step in β -oxidation;
2. formation of hydroxymethylglutaryl-CoA (HMG-CoA) by HMG-CoA synthase;
3. release of acetoacetate by HMG-CoA lyase; and
4. reduction of acetoacetate to β -hydroxybutyrate by β -hydroxybutyrate dehydrogenase.

10.4.2 Decarboxylation of acetoacetate

Notes: Acetone can form from acetoacetate through spontaneous, non-enzymatic decarboxylation. As shown in this plot (redrawn from [46]), the rate of decarboxylation is enhanced by unfractionated serum proteins. The catalytic activity of

serum is greater when ketogenesis has been induced, suggesting the existence of a specific enzyme activity. A bacterial acetoacetate decarboxylase is known and has been studied in molecular detail; however, the hypothetical mammalian enzyme remains incompletely characterized [47].

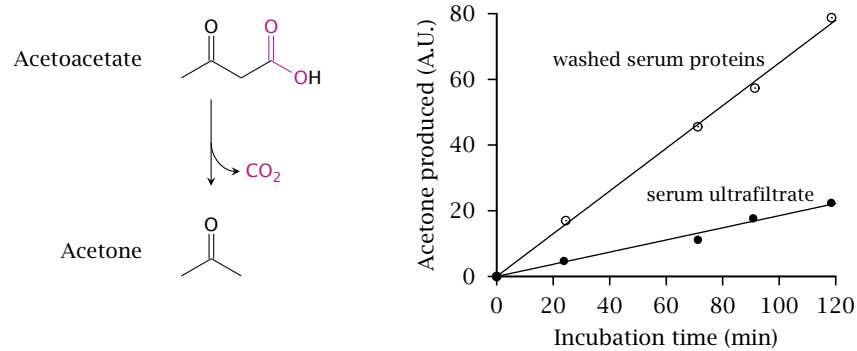

10.4.3 Acetone can serve as a precursor for gluconeogenesis

Notes: While many textbooks, even ones of recent vintage, continue to spread the myth of acetone being a useless metabolic dead end, it has been known for some time that acetone can be converted to pyruvate, which can then enter gluconeogenesis [48]. Thus, acetone provides a back door for fatty acyl carbon to be turned back into glucose. The capacity of this pathway appears to be limited; it has been estimated that up to 11% of endogenously produced glucose may be derived from acetone in fasting humans [49].

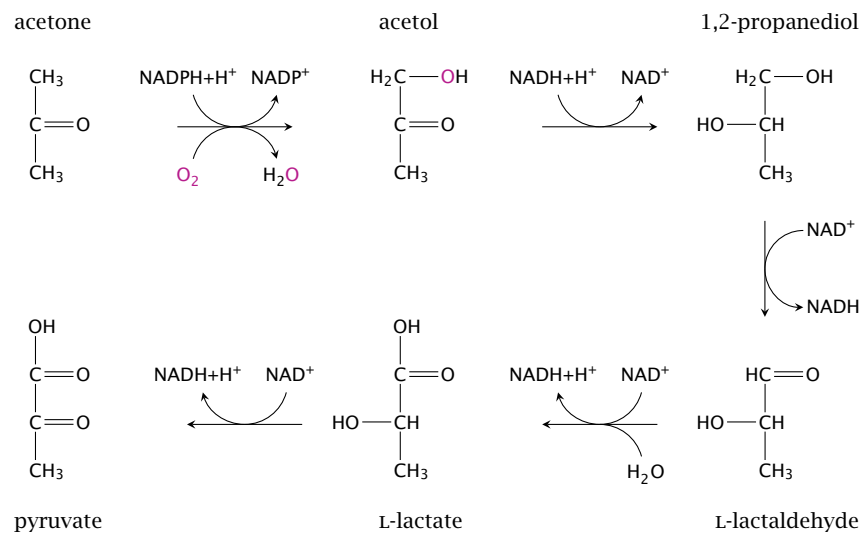

The first step of the pathway shown here is catalyzed by the enzyme cytochrome P450 type 2E1. This enzyme can also metabolize ethanol and is transcriptionally induced by both acetone and ethanol. The enzyme that converts acetol to propanediol has not been characterized; the subsequent steps are catalyzed by alcohol

dehydrogenase and aldehyde dehydrogenase, respectively, which also function in the major pathway of ethanol degradation (see slide 7.4.2).⁹



10.6 Give an outline of ketone body metabolism.

10.4.4 Anticonvulsant effects of acetone and acetol

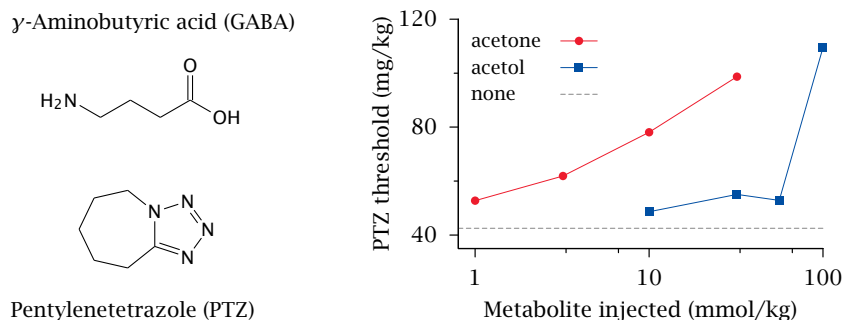

Notes: At higher than physiological plasma concentrations, acetone acts like a general anesthetic, as do many organic solvents (e.g. chloroform and diethylether). This is also the case for some antiepileptic drugs. An important common target for anesthetics and antiepileptic drugs is the GABA_A receptor, which is one of the two major inhibitory neurotransmitter receptors in the central nervous system.¹⁰

Accordingly, acetone has been proposed to be responsible for the effectiveness of the *ketogenic diet* in epilepsy. This diet was the first effective treatment of this disease [51], and it remains in use in a significant number of patients, particularly children, who don't respond to antiepileptic drugs.

The ketogenic diet restricts carbohydrates and protein, and it supplies most calories as triacylglycerol, much of which is then converted to ketone bodies. In animal experiments, acetone has greater antiepileptic potency than the two other ketone bodies and, as illustrated here, also than the metabolites formed in its own breakdown. In the experiment shown here [52], the GABA_A receptor antagonist pentylenetetrazole was used to induce epileptic seizures. Injection of acetone raises the dosage of pentylenetetrazole necessary to trigger seizures. It does this at lower concentrations than its metabolite acetol, indicating greater anticonvulsant potency.

The ketogenic diet does not work in all patients, and it seems desirable to increase its effectiveness. A possible strategy to achieve this might be to combine the diet with inhibitors of metabolic breakdown of acetone [53]. This approach is currently undergoing experimental evaluation.

⁹A second pathway from acetol to pyruvate involves the oxidation of acetol by cytochrome P450 2E1 to methylglyoxal, which is then converted to D-lactate through addition and subsequent hydrolysis of glutathione [48].

¹⁰Considering the very high concentrations of ketone bodies in diabetic coma, one might assume that acetone contributes to the causation of unconsciousness in this condition. However, a clinical study on this question has concluded that acetone is likely not a dominant factor [50].

10.5 Fatty acid synthesis

Fatty acids can be synthesized from acetyl-CoA. This is the major pathway for utilizing excess dietary carbohydrates and protein. Fatty acid synthesis occurs mainly in the fat tissue and the liver. It runs in the cytosol, which keeps it apart from mitochondrial β -oxidation. In broad outline, fatty acid synthesis is a reversal of β -oxidation: two carbon atoms at a time are added to a growing fatty acid molecule, and the new β carbon is then reduced to the alkane level. However, the mechanistic details are somewhat different.

The bulk of the work in fatty acid synthesis is accomplished by a single enzyme, fatty acid synthase, which is quite an amazing molecule: it combines six active sites with eight distinct catalytic activities on a single polypeptide chain. Its product is palmitic acid (hexadecanoic acid). As stated before, fatty acids vary in their chain lengths and degree of bond saturation. These variants are derived from palmitate through chain elongation and desaturation, which are accomplished by separate enzymes called elongases and desaturases.

10.5.1 The acetyl-CoA carboxylase reaction

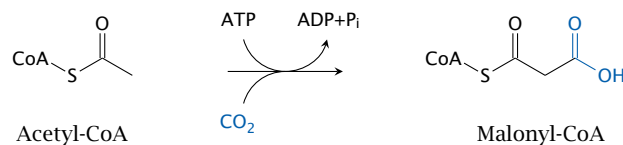

Notes: The only reaction in palmitate synthesis that is not carried out by fatty acid synthase itself is catalyzed by acetyl-CoA carboxylase. I hope that by now you recognize the pattern: CO_2 is fixed, and ATP is expended—another biotin-dependent reaction, working in the same way as pyruvate carboxylase and propionyl-CoA carboxylase.

The acetyl-CoA carboxylase reaction is performed for each C_2 subunit that is added to the growing fatty acid, except the very first one. As with pyruvate carboxylase in gluconeogenesis, the attachment of CO_2 is transient, and one can think of it simply as an activation step that facilitates subsequent C–C bond formation.

10.5.2 The structure of fatty acid synthase

Notes: All further reactions are catalyzed by fatty acid synthase. In animals, this is a large molecule with multiple active sites located on a single polypeptide chain. Two of these polypeptides form an active dimer. The active sites are highlighted in the structure (rendered from [2vz8.pdb](#)), and their locations along the sequence of the fatty acid synthase molecule are given as acronyms, as follows: KS, ketoacyl synthase; MAT, malonyl-acetyltransferase; KR, ketoacyl reductase; DH, hydroxyacyl dehydratase; ER, enoylreductase. The numbers indicate the place of each active site in the sequence of reactions. ACP is acyl carrier protein, and TE thioesterase;

these two elements were not resolved in the crystal structure of the protein, and their locations are approximate.

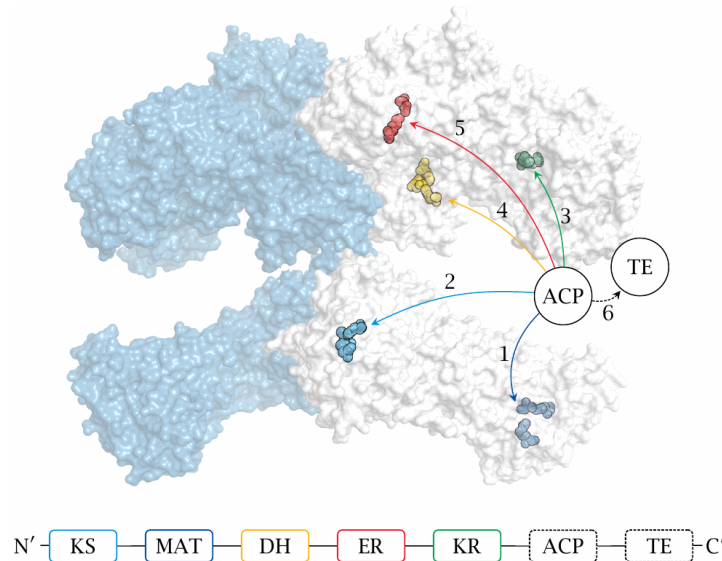

10.5.3 Phosphopantetheine acts as a flexible tether in acyl carrier protein

Notes: Throughout the repetitive cycle of reactions involved in the synthesis, the growing fatty acyl chain remains covalently attached to the enzyme. Attachment is made through a phosphopantetheine group, which functions as a flexible tether, allowing the acyl chain to travel and visit the various active sites on the enzyme in turn. This is reminiscent of the lipoamide moiety in pyruvate dehydrogenase and of biotin-dependent carboxylases.¹¹ The phosphopantetheine tether group is actually not new to us, since it also occurs in coenzyme A (see slide 10.3.1).

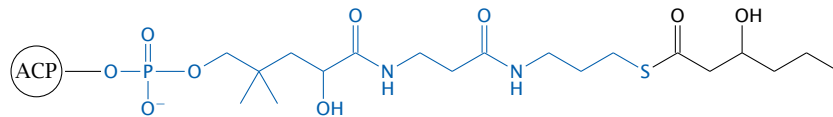

10.5.4 Fatty acid synthase reactions (1)

Notes: The reactions catalyzed by fatty acid synthase are shown in this slide and the next one.

1. Malonyl-acetyltransferase loads the first acetyl-group onto the ACP moiety. In both the substrate and the product, the acetyl group is bound as a thioester, which makes this an easy reaction.

¹¹In *E. coli*, the phosphopantetheine group is associated with a separate small protein, the acyl carrier protein (ACP). In mammalian fatty acyl synthesis, ACP is not a separate protein but is part of the synthase molecule itself.

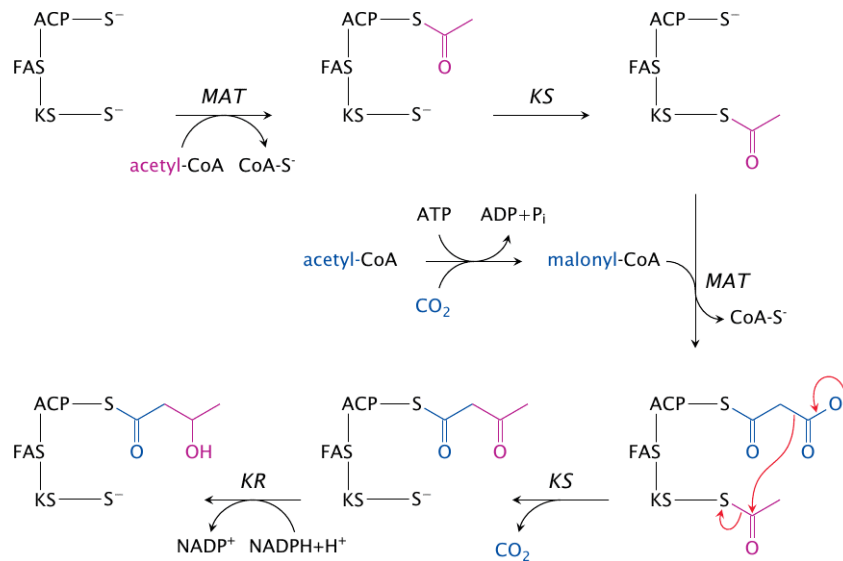

2. In another thioester transfer, ketoacyl synthase acquires the acetyl group from ACP and retains it on its active site cysteine.
3. Malonyl-acetyltransferase transfers a malonyl residue from malonyl-CoA (supplied by acetyl-CoA carboxylase) to ACP.
4. Inside the ketoacyl synthase active site, the malonyl group is decarboxylated, and the carbanion that forms in the process attacks the acetyl group that had been acquired earlier. This yields the thioester of acetoacetate.
5. Ketoacyl reductase converts acetoacetate to β -hydroxybutyrate.

10.5.5 Fatty acid synthase reactions (2)

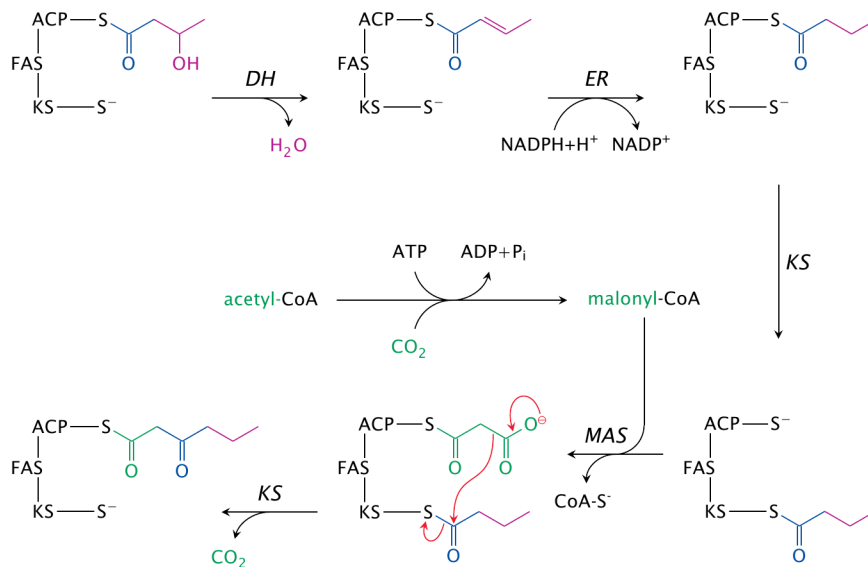

Notes: The synthesis continues from the last slide, with the following reactions:

6. hydroxyacyl dehydratase eliminates water, and

7. enoylreductase reduces the ensuing double bond. These two steps yield butyrate.
8. Ketoacyl synthase acquires the butyrate, freeing up ACP.
9. Malonyl-acetyltransferase acquires the next malonyl residue from malonyl-CoA, which is again supplied by acetyl-CoA carboxylase.

From this point on, the cycle repeats—ketoacyl synthase decarboxylates malonate and forms the next β -keto acid, ketoacyl reductase reduces it, and so on. The cycle executes seven times overall, which results in the formation of palmitate; the palmitoyl residue is then released as free palmitate by the thioesterase activity of fatty acid synthase.



10.7 Give an outline of fatty acid synthesis.

10.5.6 Mitochondrial export of acetyl-CoA via citrate

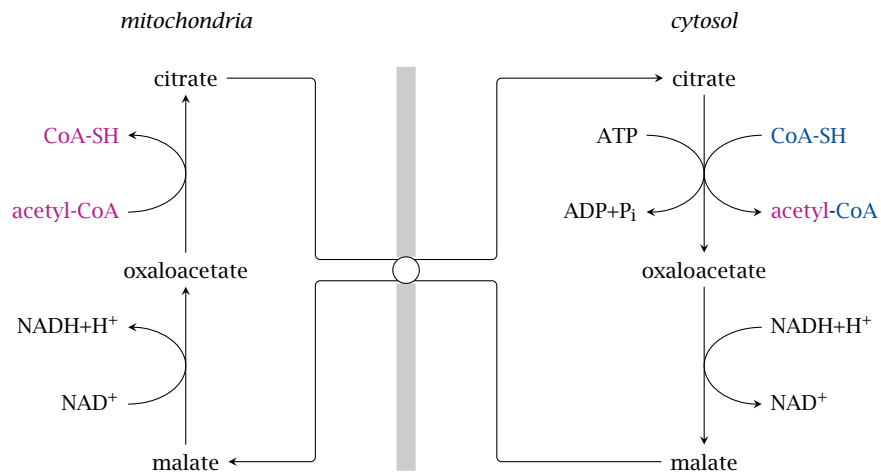

Notes: We have noted above that fatty acid synthesis occurs in the cytosol. Since acetyl-CoA is formed in the mitochondrion by pyruvate dehydrogenase, it needs to get out of the mitochondrion and into the cytosol.

We saw before that there is a similar problem in β -oxidation. In that case, the transport of acyl-CoA to the mitochondria is accomplished by the carnitine carrier system (slide 10.3.2). Since all reactions in the latter system are reversible, and acetyl-CoA is also an acyl-CoA, we might expect that the carnitine carrier system could help us out here as well. On the other hand, if transport of acyl-CoA molecules went both ways, this might facilitate a futile cycle of fatty acid synthesis and degradation.

It turns out that acetyl-CoA is indeed transported by other means. One of them is illustrated in this slide. Here, citrate is exported by the tricarboxylate carrier system. Cleavage by ATP-citrate lyase reverts the citrate synthase reaction, producing acetyl-CoA and oxaloacetate. The latter is reduced by malate dehydrogenase, and malate is exchanged for citrate. As you can see, this process will also transport one NADH equivalent to the mitochondria, which is usually accomplished by dedicated shuttle systems (section 6.9).

10.5.7 Mitochondrial export of acetyl-CoA via acetoacetate

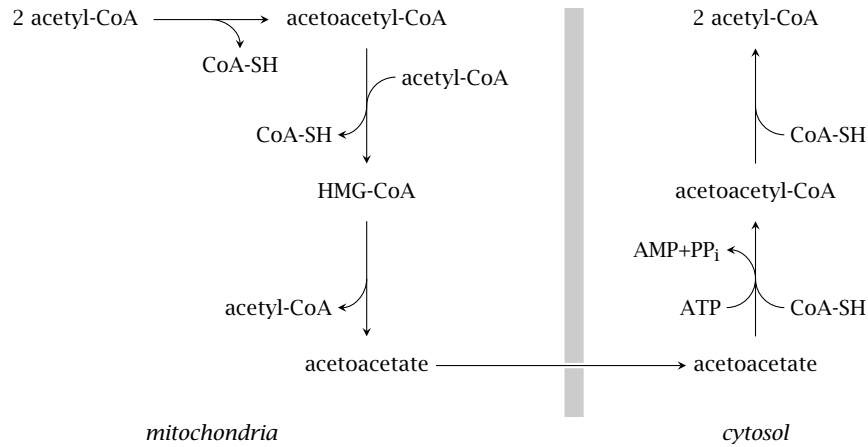

Notes: A fairly straightforward transport mechanism consists in the export of acetoacetate, which is generated in the mitochondria by the ketogenesis pathway (see slide 10.4.1). Acetoacetate can be converted back to acetyl-CoA by cytosolic acetoacetyl-CoA synthetase, which uses ATP, and then cleaved to two molecules of acetyl-CoA by thiolase. The pathway has been demonstrated in rat livers [54, 55] and is also found in high activity in adipose tissue [56].

Fatty acid synthesis also requires a large amount of NADPH in the cytosol. This can be supplied by the hexose monophosphate shunt, but shuttles that export NADPH from the mitochondria also contribute (see slide 9.3.2f).



10.8 Explain how the acetyl-CoA needed for fatty acid synthesis is exported from the mitochondria to the cytosol.

10.5.8 Elongation and desaturation of fatty acids

- elongases reside in mitochondria and endoplasmic reticulum
- chemistry of elongation similar to β -oxidation in mitochondria, similar to fatty acid synthase in the ER
- desaturases occur in the ER, introduce double bonds at various positions
- double bonds are created at least 9 carbons away from the ω end— ω -3 fatty acids cannot be formed and are therefore *essential*

Notes: Palmitate is the end product released by fatty acid synthase; fatty acids with longer chains are formed from palmitate by separate elongase enzymes. Inside the mitochondria, the pathway of elongation is mostly a reversal of β -oxidation, except that NADPH is used instead of FADH_2 in the final reduction of enoyl-CoA. In the ER, the chemistry resembles that of fatty acid synthase, except that the substrate is bound to coenzyme A rather than to the enzyme itself.

Desaturases contain iron and cooperate with several other redox-active proteins in the ER membrane; the hydrogen abstracted from the fatty acid is transferred to molecular oxygen. None of the human or animal desaturases can intro-

duce double bonds closer than 9 carbons away from the ω end—that is, non-carboxyl end—of the substrate. Since we require ω -3 and ω -6 fatty acids as synthetic precursors of membrane lipids and of prostaglandins, such fatty acids are *essential*, that is, they must be obtained from the diet. All ω -3 and ω -6 fatty acids ultimately originate in plant metabolism, even if we may ingest them with animal-derived food.

10.5.9 Cerulenin, an antibiotic that irreversibly inhibits fatty acid synthase

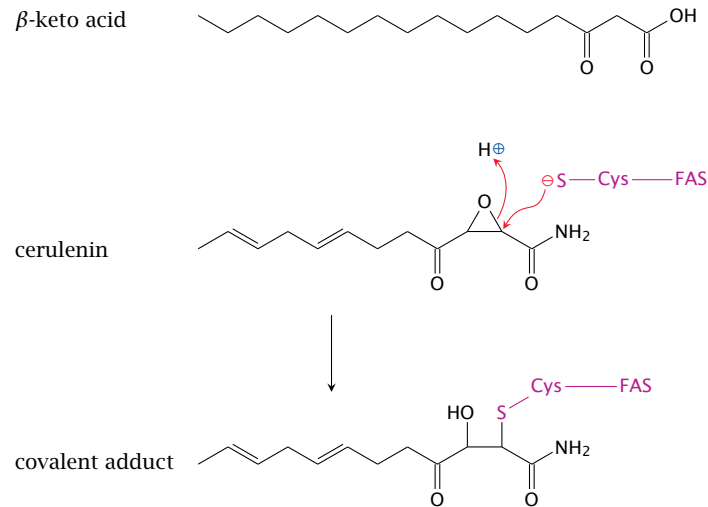

Notes: Cerulenin is a fungal antibiotic that binds and irreversibly inactivates fatty acid synthase. Its structure resembles the β -ketoacyl intermediates of fatty acid synthesis, and indeed cerulenin binds to the ketoacyl synthetase site of the enzyme. The cysteine residue in this site then reacts with the epoxide ring in cerulenin and is alkylated.

While epoxide derivatives are not terribly popular as drugs because they tend to be quite reactive and often toxic, there is presently some interest in the development of fatty acid synthase inhibitors, modeled on the structure of cerulenin, for the treatment of obesity. While this does not strike me as a particularly promising idea,¹² a more interesting application is in the treatment of cancer. This is discussed in the next slide.

10.5.10 Fatty acid synthase inhibition slows tumor growth in mouse experiments

Notes: Most non-cancerous cells do not express fatty acid synthase, relying instead on fatty acids supplied by the liver and fat tissue. However, fatty acid synthase expression has been observed in cancer cells. The cells probably use these fatty

¹²I look forward to the discoveries of metabolic derailments these drugs will cause in the face of continued excess caloric intake. What is going to become of the surplus acetyl-CoA when fatty acid synthesis is inhibited: Ketone bodies? Cholesterol? Will glycolysis be backed up and diabetes be induced? All of the above?

acids to supply their synthesis of membrane glyco- and phospholipids, which they require for proliferation. In any event, inhibition of fatty acid synthase in tumor cells can drive them into apoptosis (programmed cell death).

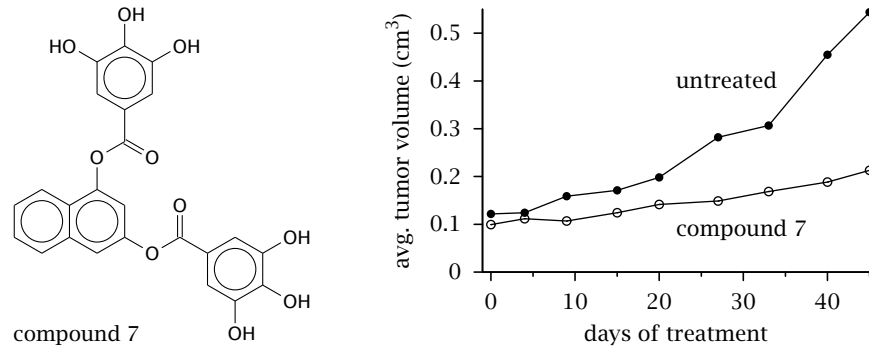

This slide shows an experimental synthetic drug (with the provisional name “compound 7”) that is somewhat similar to polyphenols occurring in green tea and other natural sources. In mice experiments, it substantially reduces the growth rate of transplanted cancer. While such experimental cancers are notorious for being easier to treat than actual clinical cancer in humans, the results suggest that this line of research is worth pursuing. Figure prepared from original data in [57].

10.6 The glyoxylate cycle

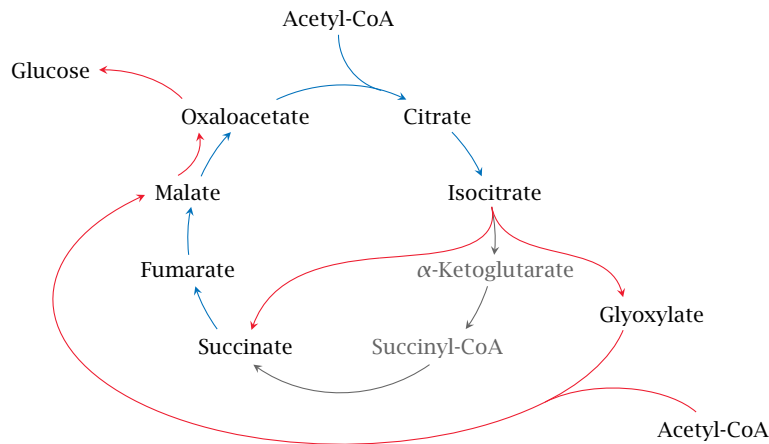

Notes: It was discussed before that carbon contained in fatty acids cannot be utilized efficiently for gluconeogenesis, since there is no efficient pathway to convert the acetyl-CoA that results from their breakdown into TCA cycle intermediates (see section 5.6 and slide 10.1.2). Interestingly, however, plants *do* have a straightforward pathway to do just this, namely, the glyoxylate cycle, which is an ancillary road to the TCA cycle.

In the glyoxylate cycle, the two decarboxylation steps of the TCA cycle are skipped, and an entry point for a second molecule of acetyl-CoA is created. In this

manner, plants are able to use two molecules of acetyl-CoA for the net synthesis of one C₄ TCA cycle intermediate.

10.6.1 Reactions in the glyoxylate cycle

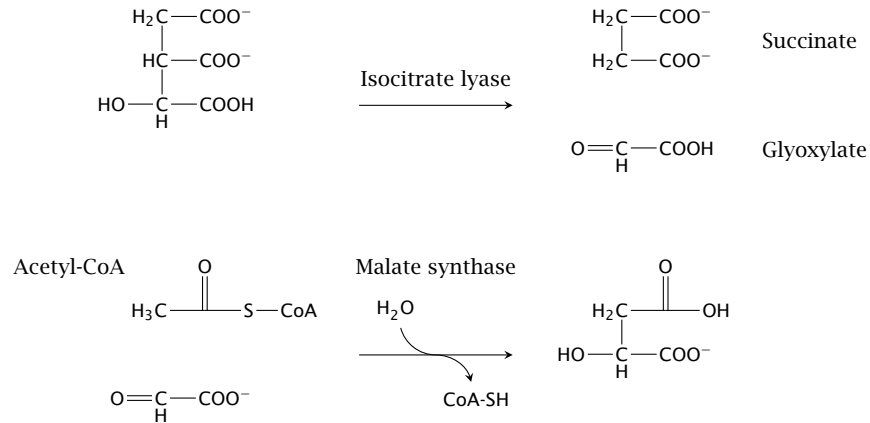

Notes: The cycle involves two reactions, both of which are mechanistically similar to citrate synthase:

1. Isocitrate is split into succinate and glyoxylate by isocitrate lyase. Since the isocitrate dehydrogenase and the α -ketoglutarate dehydrogenase reactions are bypassed, the loss of two carbons as CO₂ is avoided; these carbons are retained in the form of glyoxylate.
2. Glyoxylate combines with the second acetyl-CoA molecule to form malate. This reaction is catalyzed by malate synthase, and like the citrate synthase reaction it is pushed forward by the concomitant hydrolysis of coenzyme A.

You know that many plant seeds are very rich in oil—that is, fat. The glyoxylate cycle enables plant seeds to store metabolic energy and carbon at high density as fat, and to use it for the synthesis of glucose and other carbohydrates during germination.

10.7 Answers to practice questions

10.1: Glycogen consists of glucose and can be readily converted back to it; triacylglycerol can not be efficiently converted to glucose but instead yields only free fatty acids and ketone bodies, which cannot be utilized by some tissues. However, the energy density of hydrated glycogen is much lower than that of triacylglycerol.

10.2: Ingested triacylglycerol is solubilized by bile acids and cleaved by pancreatic lipase. The cleavage products—free fatty acids, glycerol and monoacylglycerol—are taken up into the epithelia of the small intestine, joined into triacylglycerol again and packaged into chylomicron particles. The latter enter the circulation via the lymphatics. In the capillaries of the circulation, lipoprotein lipase extracts triacylglycerol and cleaves it. The free fatty acids produced are mostly either consumed by muscle cells or stored as triacylglycerol in fat cells.

10.3: See scheme in slide 10.3.3

10.4: β -Oxidation provides 7 equivalents of NADH and FADH_2 each, as well as 8 equivalents of acetyl-CoA. Oxidation of the latter in the TCA cycle provides 24 more equivalents of NADH and 8 more of FADH_2 . Assuming a yield of 3 ATP per NADH and 2 per FADH_2 , this works out to $(24 + 7) \times 3 + (8 + 7) \times 2 = 123$ equivalents of ATP.

10.5: Fatty acids with regular chain lengths are first activated to acyl-CoA in the cytosol, then transported across the outer mitochondrial membrane and converted to acylcarnitine, exchanged for carnitine across the inner mitochondrial membrane, and finally converted to acyl-CoA again in the mitochondrial matrix.

Medium chain fatty acids skip all these preliminaries and simply reach the mitochondrial matrix by diffusion.

10.6: Ketone bodies are acetoacetate, β -hydroxybutyrate and acetone. Acetoacetate and β -hydroxybutyrate are synthesized in the liver and can, to a degree, replace glucose as an energy substrate for the brain and other tissues when glucose supply is low.

The major substrate for ketone body synthesis are free fatty acids mobilized from fat tissue by hormone-sensitive lipase. β -Oxidation in the liver produces acetyl-CoA, which in turn is converted to acetoacetate and its reduction product β -hydroxybutyrate. Utilization of ketone bodies proceeds through conversion back to acetyl-CoA.

Acetone arises from spontaneous as well as enzymatic decarboxylation of acetoacetate. It can be converted to pyruvate through an oxidative pathway that starts with its conversion to acetol; since pyruvate can feed into gluconeogenesis, this provides a "back door" for the conversion of some carbon from fatty acids to glucose.

10.7: Fatty acid synthesis occurs in the cytosol and is mostly carried out a single enzyme, namely, fatty acid synthase. The process is somewhat similar to β -oxidation, but it employs NADPH in both reduction steps, and it also involves transient activation of acetyl-CoA to malonyl-CoA by acetyl-CoA carboxylase. The product is palmitate, which may undergo desaturation elongation by additional enzymes.

10.8: It can be exported either as citrate, which is then cleaved by ATP citrate lyase to oxaloacetate and acetyl-CoA, or as acetoacetate, which is then activated by a thiokinase and cleaved to two molecules of acetyl-CoA by thiolase.

Chapter 11

Cholesterol metabolism

11.1 Biological significance of cholesterol

- Cholesterol is an essential lipid constituent of cell membranes
- Cholesterol is a precursor of steroid hormones and of bile acids
- Intermediates of cholesterol biosynthesis are required to make vitamin D and for posttranslational modification of membrane proteins
- High plasma cholesterol promotes atherosclerosis

Notes: Contrary to popular belief, the biological role of cholesterol is not limited to being the bad guy. Instead, it has a number of essential physiological functions:

1. In humans and animals, cholesterol is a major constituent of the cell membranes. Cholesterol modulates physical properties of these membranes that in turn affect the function of membrane proteins such as receptors and transporters. Experimental depletion of membrane cholesterol cripples many cellular functions.
2. Cholesterol is the biosynthetic precursor of bile acids, which are essential for fat digestion.
3. Cholesterol is the precursor of all steroid hormones, namely, androgens, estrogens, progestins, glucocorticoids, mineralocorticoids, and calciferol (vitamin D).

Nevertheless, it certainly is true that cholesterol also plays a major role in the pathogenesis of atherosclerosis. In this chapter, we will first cover the metabolic pathways that involve cholesterol, and then take a look at the role of cholesterol in this important cardiovascular disease.

11.1.1 Processes that determine the cholesterol balance

- intestinal uptake of dietary cholesterol
- *de novo* cholesterol synthesis
- synthesis of steroid hormones from cholesterol
- synthesis of bile acids from cholesterol, and their biliary secretion
- biliary secretion of surplus cholesterol in unmodified form

Notes: Cholesterol can both be synthesized endogenously and obtained from the diet. Note that significant amounts of cholesterol only occur in meat, eggs, and milk products; plants and mushrooms contain other sterols but very little cholesterol. The fact that vegetarians survive tells us that our capacity to synthesize cholesterol suffices to cover our need for cholesterol entirely.



11.1 What are dietary sources of cholesterol? Do we require cholesterol in the diet?

11.2 Cholesterol synthesis

The pathway of cholesterol synthesis is quite elaborate. We will start with a general outline and then go through most, but not all of the reactions in detail.

11.2.1 Overview of cholesterol synthesis

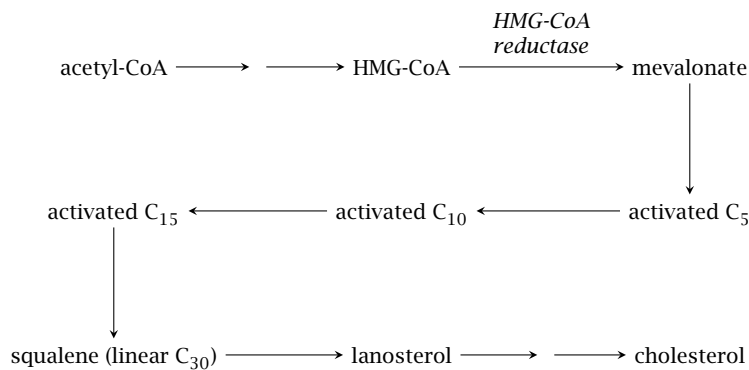

Notes: Cholesterol synthesis starts with acetyl-CoA, which is used to synthesize hydroxymethylglutaryl-CoA (HMG-CoA). The reactions in this initial stage are the same as in ketogenesis (see slide 10.4.1). However, while ketogenesis occurs in the mitochondria, HMG-CoA destined for sterol synthesis is formed in the cytosol. Therefore, like the synthesis of fatty acids, cholesterol biosynthesis depends on the export of acetyl-CoA from the mitochondria. Also as with fatty acids, multiple steps in the cholesterol synthesis require NADPH. How these two requirements are met has been discussed earlier (see slide 10.5.6f).

All steps downstream of HMG-CoA occur in the smooth endoplasmic reticulum. HMG-CoA reductase reduces HMG-CoA to mevalonate; this enzyme is the major target of regulation in the entire pathway. Mevalonate is converted to various isoprene intermediates. Several rounds of “polymerization”—I’m using the term

loosely—produce the linear hydrocarbon molecule squalene, which is cyclized to the first sterol intermediate. This molecule, lanosterol, is then converted to cholesterol by several successive modifications.



11.2 Which reaction is the major regulatory step in cholesterol synthesis?

11.2.2 Initial activation steps in cholesterol synthesis

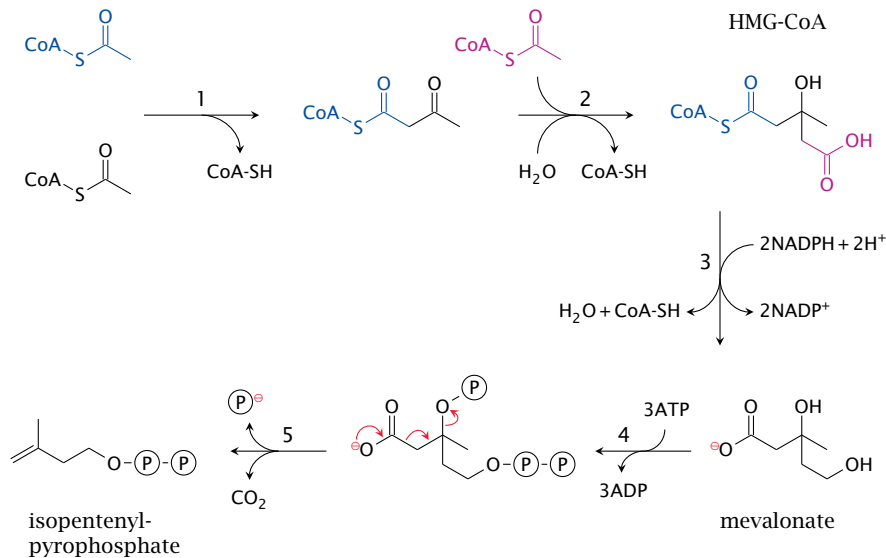

Notes: The reactions shown in this slide are catalyzed by thiolase (1), HMG-CoA synthase (2), HMG-CoA reductase (3), mevalonate kinase and phosphomevalonate kinase (4), and diphosphomevalonate decarboxylase (5). In the subsequent steps of the pathway, six molecules of isopentenyl-pyrophosphate are used for the synthesis of one cholesterol molecule.

11.2.3 Formation of a C₁₀ intermediate

Notes: The next stage begins with the conversion of one molecule of isopentenyl-pyrophosphate to dimethylallyl-pyrophosphate, catalyzed by the isopentenyl-pyrophosphate isomerase. The product is condensed with another molecule of isopentenyl-pyrophosphate to yield geranyl-pyrophosphate. In this reaction, catalyzed by geranyl-pyrophosphate synthase, the pyrophosphate of the first substrate serves as a leaving group. The resulting carbocation reacts with the double bond of the second substrate.

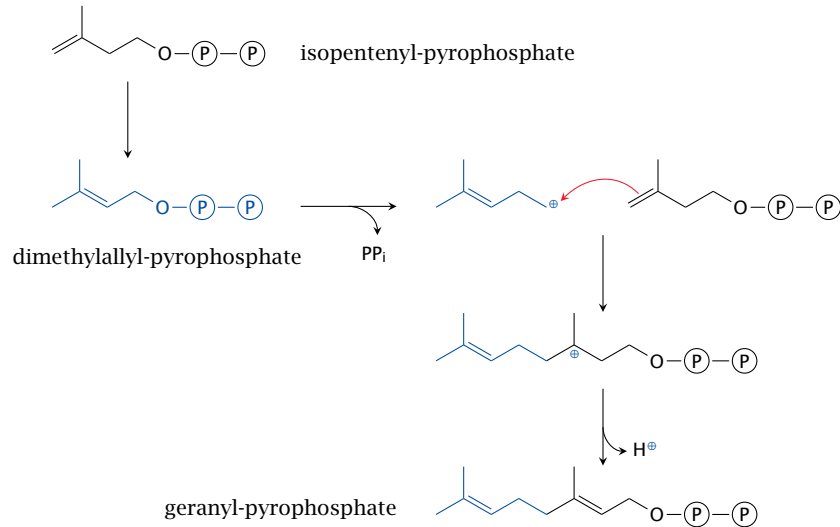

11.2.4 Formation of C₁₅ and C₃₀ intermediates

Notes: The synthesis of the C₁₅ intermediate, farnesyl-pyrophosphate, is catalyzed by the eponymous synthase and mechanistically resembles that of geranyl-pyrophosphate. Farnesyl-pyrophosphate is used not only in sterol synthesis but also in the posttranslational modification of some membrane-associated proteins. While the amount of farnesyl-pyrophosphate used for this purpose is not very large, inhibition of protein farnesylation may contribute to the clinical effect of inhibitory drugs that act upstream in this pathway; this includes the statins, which inhibit HMG-CoA reductase (see slide 11.7.2).

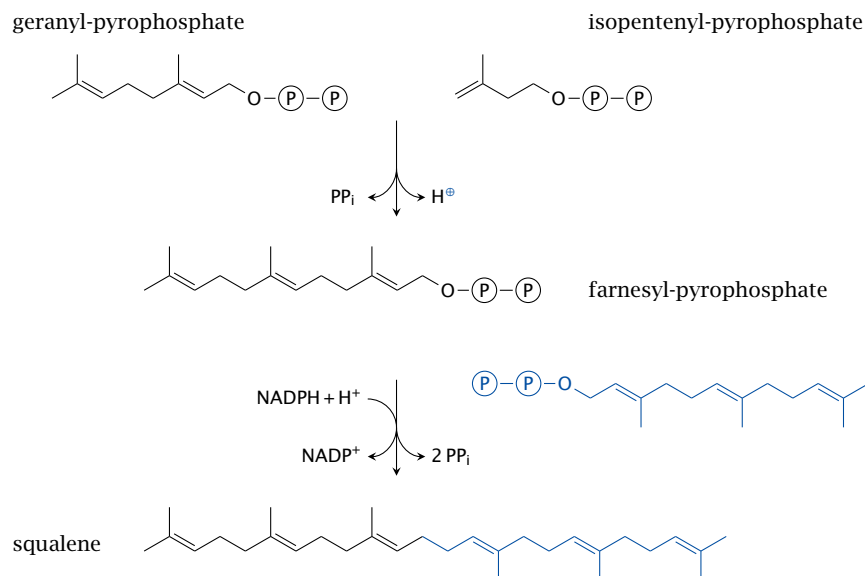

Two molecules of farnesyl-pyrophosphate are joined head to head in the synthesis of the final linear sterol precursor, namely, squalene; the enzyme is named squalene synthase.

11.2.5 Squalene cyclization yields the first sterol intermediate

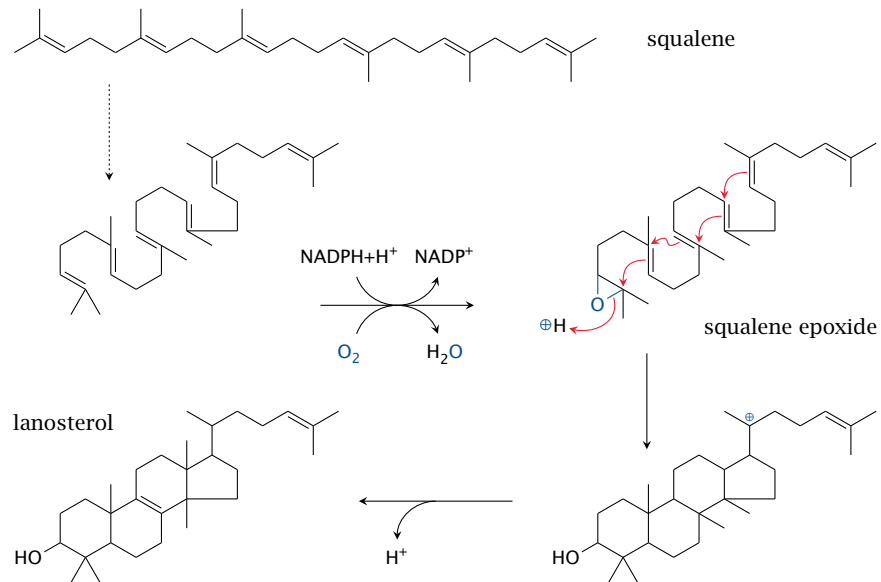

Notes: The reactions shown here are catalyzed by squalene epoxidase and lanosterol synthase. The rearrangement indicated by the dashed arrow is not a real reaction—we just rotate a couple of single bonds to show how the pieces fall into place for the subsequent cyclization.

The oxygen is introduced by squalene epoxidase, a cytochrome P450 enzyme. Such enzymes use NADPH to reduce one of the two atoms of molecular oxygen, while retaining the other one in a highly reactive state, which they then use toward their specific purposes (see slide 18.2). Squalene synthase inserts its active oxygen into a C=C double bond of the substrate to form an epoxide. The subsequent cleavage of the epoxide by lanosterol synthase starts a cascade of reactions that goes from one end of the molecule to the other, closing all four rings of the sterol skeleton in the process. Note that a methyl group also changes its place on the sterol ring; the reaction mechanism is quite intricate.

11.2.6 Demethylation, desaturation and saturation steps convert lanosterol to cholesterol

Notes: Several successive modifications convert lanosterol to 7-dehydrocholesterol and then cholesterol. Like squalene epoxidase, several of the enzymes that catalyze these reactions also belong to the cytochrome P450 family. We will not consider them in detail; however, several of these enzymes are inhibited by the

drug triparanol, which was once used to treat hypercholesterolemia before being withdrawn due to toxicity.

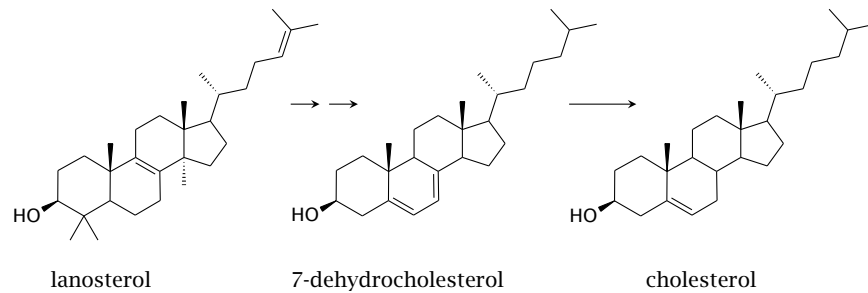

11.3 What is the role of cytochrome P450 enzymes in the synthesis of cholesterol?

11.2.7 UV-dependent synthesis of cholecalciferol

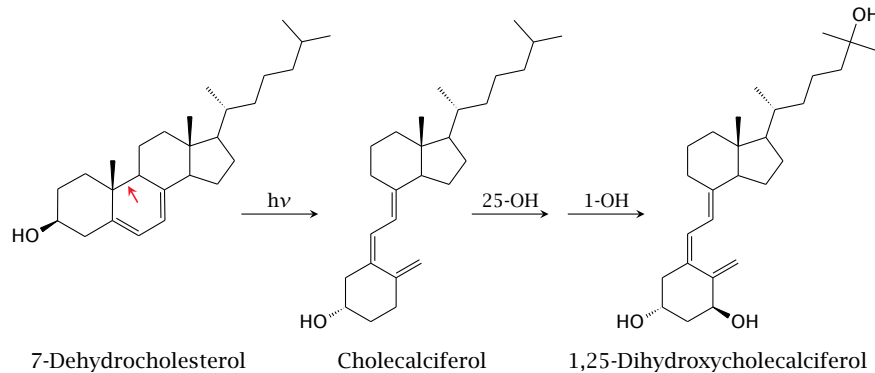

Notes: The last biosynthetic precursor of cholesterol, 7-dehydrocholesterol, is also the precursor of vitamin D₃ (cholecalciferol). The conversion of 7-dehydrocholesterol to cholecalciferol, which involves the breakage of the bond indicated by the red arrow, is a photochemical reaction; it requires the absorption of a UV photon and can therefore only occur in the skin. Two successive enzymatic hydroxylations (which do not require any more UV light) yield 1,25-dihydroxy-cholecalciferol. This molecule is a transcriptional regulator that activates the uptake of calcium and phosphate from the gut.

A lack of 1,25-dihydroxy-cholecalciferol causes *rickets*, a formerly quite common disease that is characterized by lack of bone mineral and bone deformities. Cholecalciferol is also the vitamin *du jour*, and if we are to believe the news, the deficiency also causes depression, cancer, earthquakes, and at least 105% of all other evils befalling mankind.

The essential function of 1,25-dihydroxycholecalciferol is responsible for the variation of human skin colors. While dark pigment protects the skin from damage by UV irradiation, the UV photons swallowed up by the pigment are no longer available for the synthesis of cholecalciferol. When *Homo sapiens* left Africa's sun for cloudier climates, the shortage of sunshine created a selective pressure for lighter skin, which increases the availability of photons for cholecalciferol synthesis. The

remarkably pale skin of people of British or Irish descent tells you all you need to know about the weather in those places. Avoid.



11.4 What are the metabolic roles of 7-dehydrocholesterol?

11.2.8 Sterol metabolism occurs in the smooth endoplasmic reticulum

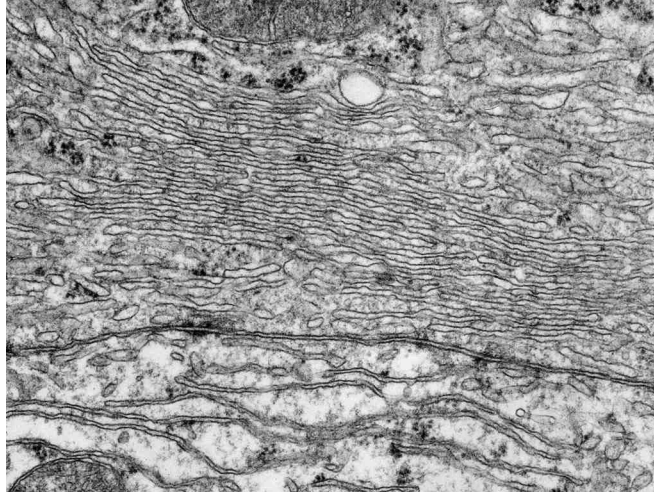

Notes: Many intermediates in the synthesis of cholesterol and of its derivatives are very hydrophobic and very poorly soluble in water; they therefore have to reside in an apolar environment. On the other hand, the enzymes, like almost all proteins, are at least partially polar and cannot immerse completely in the same apolar environment.

The solution to this problem is to perform the reactions at the interface of polar and apolar environments, that is, at membrane surfaces. This means that the membrane of the smooth ER is not just there to delimit a separate compartment—it *is* a reaction compartment all by itself. Accordingly, liver cells and other cells that engage in sterol chemistry have a well developed smooth ER with a very large cumulative membrane surface area.

The ER also hosts many enzymes that function in drug metabolism, including cytochrome P450 and UDP-glucuronosyltransferases (see chapter 18). The functional context is the same—many drug molecules that must undergo metabolism before being eliminated are quite hydrophobic and thus also require interfacial chemistry.

11.3 Regulation of cholesterol synthesis

HMG-CoA reductase subject to feedback inhibition by cholesterol. Additionally, its activity is subject to transcriptional regulation, which occurs through a rather unique mechanism.

11.3.1 Transcriptional regulation of cholesterol synthesis starts in the ER

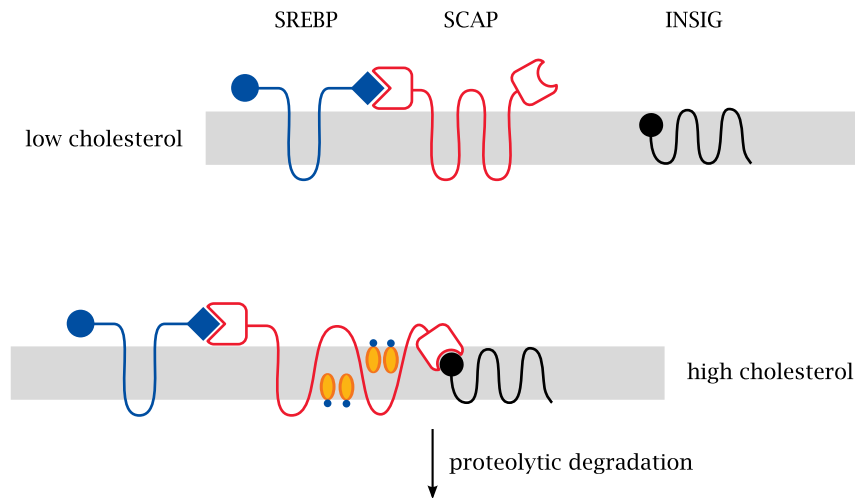

Notes: The *sterol response element* (SRE) is a DNA consensus sequence that controls the transcription of HMG-CoA reductase. The corresponding SRE-binding protein (SREBP) is initially embedded in the ER membrane, and thus evidently unable to get in touch with its DNA target. SREBP is bound to a second protein, namely, SREBP cleavage activating protein (SCAP). This protein is the actual cholesterol sensor; it can adopt two different conformations, depending on the content of cholesterol in the surrounding membrane. The conformation that predominates at high cholesterol content lets SCAP bind to a third protein, INSIG.¹ When this ternary complex forms, it is rapidly targeted toward proteolytic degradation, and that is the end of it.

At low cholesterol concentrations, however, SCAP does not bind to INSIG, and this is when things get interesting, as shown in the next slide.

11.3.2 When cholesterol is low, SREBP is sorted to the Golgi apparatus

Notes: At low cholesterol concentrations, SCAP binds to some other membrane proteins (shown in green) that recruit it into nascent vesicles, and it takes SREBP along for the ride. When these vesicles bud off from the ER membrane, they travel to the Golgi apparatus and fuse with its membrane. The Golgi is a cellular organelle that performs many types of posttranslational protein modifications, such as glycosylation, lipid modification, and proteolytic processing.

¹INSIG stands for “insulin-induced gene.”

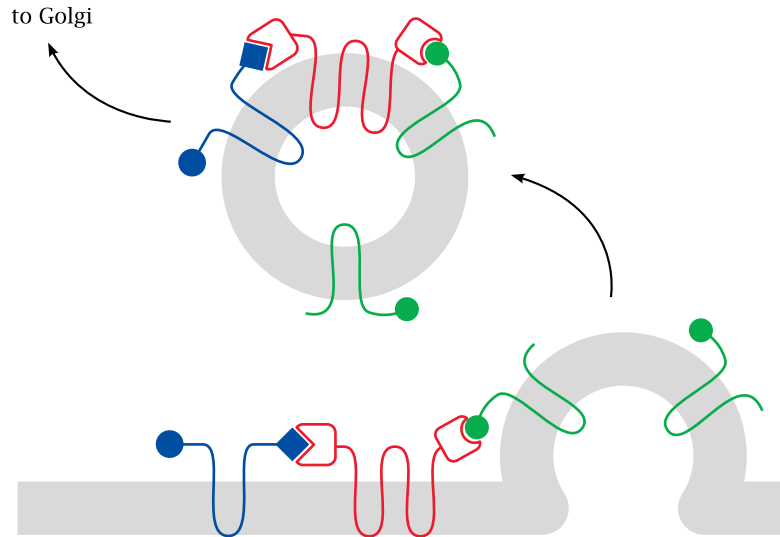

11.3.3 Proteolytic cleavage in the Golgi releases SREBP

Notes: Once SREBP reaches the Golgi, it is ambushed and cleaved by two specific proteases (S1P and S2P). Cleavage releases the DNA-binding domain of the protein from the membrane. This fragment then moves across the cytosol and enters the nucleus, where it binds to SRE sequence elements that increase the expression of HMG-CoA reductase and also of various other enzymes from the cholesterol synthesis pathway [58].

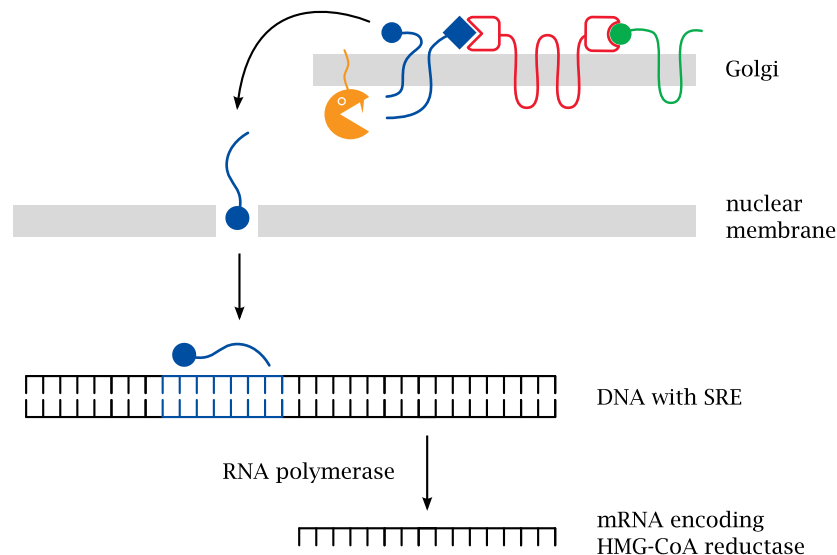

Another protein that is upregulated by SREBP and SRE is the LDL receptor, a membrane protein that mediates endocytosis of low density lipoprotein (LDL; see slide 11.4.7). In cells that do not synthesize cholesterol themselves, SREBP upregulates transcription of the LDL receptor,

Like SREBP and SCAP, HMG-CoA reductase is anchored in the ER membrane. This does not seem necessary for the chemistry it performs. Instead, this location facilitates the negative feedback regulation imposed on it by cholesterol. Indeed, the enzyme contains a sterol-sensing domain that is homologous to the one found in SCAP [59].



11.5 How does the transcriptional regulation of cholesterol biosynthesis work?

11.4 Cholesterol transport

Like other lipids, cholesterol has low water solubility and therefore requires special mechanisms and vehicles for transport. In the bloodstream, both cholesterol and triacylglycerol are transported within lipoproteins.

11.4.1 Lipoprotein structure

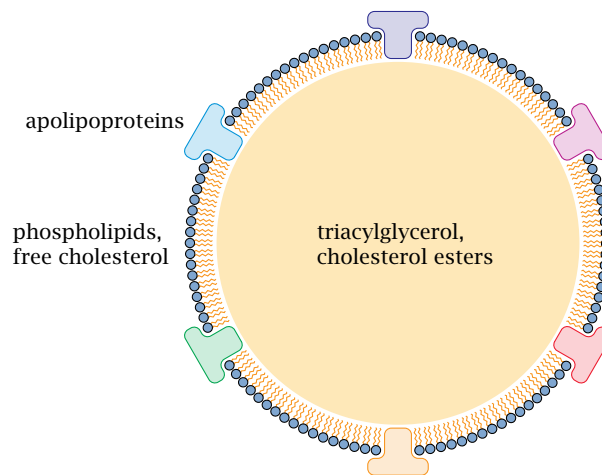

Notes: We had already encountered one type of lipoprotein, namely, the chylomicrons, which are formed in the intestinal mucosa (see slide 10.2.3). Different lipoprotein types vary in composition and particle size, but the overall structure is similar for all of them. The surface consists mainly of phospholipids, which form a monolayer.

Apolipoproteins are embedded into the surface of the particle. These protein molecules mainly serve as “address tags” that mediate the interaction with target molecules and cells, such as lipoprotein lipase on endothelial cells (slide 10.2.6) or the LDL receptor (see later). Some apolipoproteins are stably associated with their lipoprotein particles; for example, a given molecule of apolipoprotein B remains associated with the same chylomicron or VLDL (very low density lipoprotein, see below) particle throughout its lifetime. Exchangeable apolipoproteins have regulatory roles; for example, apolipoprotein CII reversibly associates with VLDL particles and activates their interaction with lipoprotein lipase.

11.4.2 Classification of plasma lipoproteins

	Chylomicrons	VLDL	LDL	HDL
Density (g/ml)	0.95	0.95–1.0	1.02–1.06	1.06–1.12
Origin	small intestine	liver	liver	liver
Function	distribute dietary TAG and cholesterol	distribute TAG from liver	distribute cholesterol from liver	return excess cholesterol to liver
Predominant lipid species	TAG	TAG	cholesterol	phospholipids, cholesterol

Notes: As you will notice, the variation in density between the various lipoproteins is modest, but it is large enough to allow their separation by density gradient centrifugation, and they are classified according to their behavior in this fractionation procedure. As noted before, ‘LDL’ stands for low density lipoprotein; ‘HDL’ means high density lipoprotein, and ‘VLDL’ is very low density lipoprotein. The differences in density arise from two circumstances:

1. Lipids are lighter than protein. Within the particles, proteins are found only at the surface, whereas the interior contains only lipids; therefore, the fractional content of protein is lower with larger particles than with smaller ones. Chylomicrons are the largest and least dense lipoprotein species.
2. Triacylglycerol is lighter, but cholesterol is heavier than water. Accordingly, a high content of cholesterol in the lipid fraction will also increase the overall density.

Note the central role of the liver, which orchestrates most of the lipid transport, with the exception of intestinal lipid uptake and packaging into chylomicrons. We will now first look at the uptake of cholesterol in the intestine and then at its transport to other organs.

11.4.3 Two membrane proteins control the uptake of sterols from the intestine

Notes: The uptake of cholesterol by intestinal epithelial cells begins with endocytosis. This process is controlled by NPC1L1, a membrane protein which is deficient in a lipid storage disorder known as Niemann-Pick disease. NPC1L1 is a sterol sensor and promotes cholesterol uptake through endocytosis.

From the endocytotic vesicles, cholesterol is transferred to the endoplasmic reticulum by the *microsomal triglyceride transfer protein* (MTTP). Acylation by acyl-CoA cholesterol acyltransferase (ACAT) yields a cholesterol ester, which is loaded into a nascent chylomicron together with triacylglycerol. After the chylomicrons

have been released from the intestinal cells and reached the circulation via the lymphatics, most of their triacylglycerol is depleted by capillary lipoprotein lipase. The cholesterol stays behind in the chylomicron remnants, which are taken up and utilized in the liver (see slide 10.2.6).

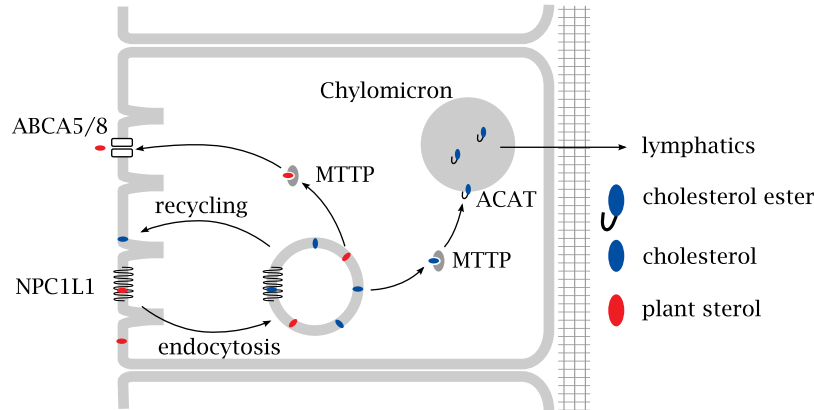

In contrast to what its name suggests, MTP transports not only triacylglycerol but also sterols. Mutational inactivation of this protein results in *abetalipoproteinemia*.² Such patients have reduced levels of chylomicrons and are affected by malabsorption of lipids and of lipid-soluble vitamins.

The NPC1L1-mediated uptake of cholesterol by endocytosis does not discriminate between cholesterol and other, structurally similar sterols derived from plants. After uptake, the latter are diverted toward a transport protein in the apical membrane, ABCA5/8, which expels them right back into the gut lumen through active transport.

 **11.6** How is cholesterol taken up in the small intestine?

11.4.4 Plant sterol structures

Notes: Plants contain little cholesterol but instead contain a variety of structurally similar sterols. The sterol ring is the same as with cholesterol in all sterols shown, but the tails are somewhat different.

Plant sterols compete with cholesterol for “space” inside the cytoplasmic membrane of intestinal cells, and therefore reduce the rate of cholesterol absorption by endocytosis. Dietary application of sitosterol or other plant sterols is a moderately effective strategy to reduce cholesterol absorption.

 **11.7** How do plant sterols influence intestinal cholesterol uptake?

²The name of “abetalipoproteinemia” denotes the lack of apolipoprotein B, which is the major protein constituent of both chylomicrons and VLDL.

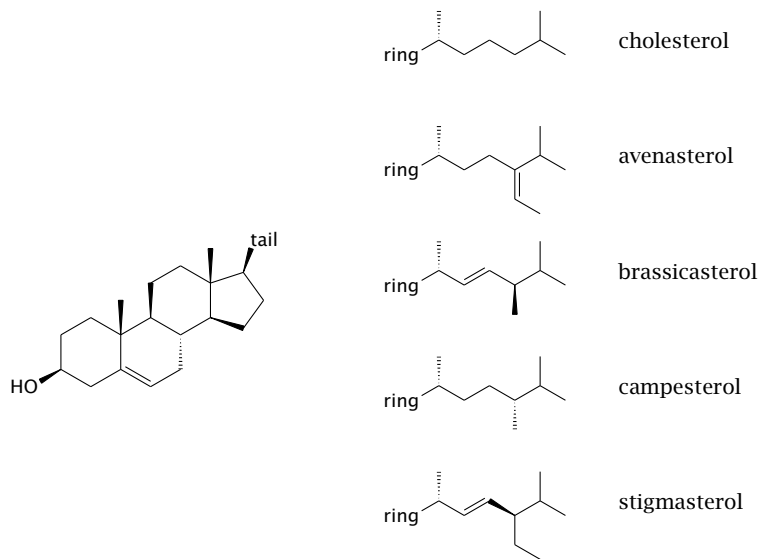

11.4.5 Structures of ABC transporters in the inward-open and outward-open conformations

Notes: Both ABCA5/8 (previous slide) and ABCA1 (slide 11.4.7) are members of the ATP-binding cassette or ABC family of transporters. These have a common structural organization. Several ABC transporters have been crystallized in the inward- and outward open conformations, and the structures provide a glimpse of how they work.

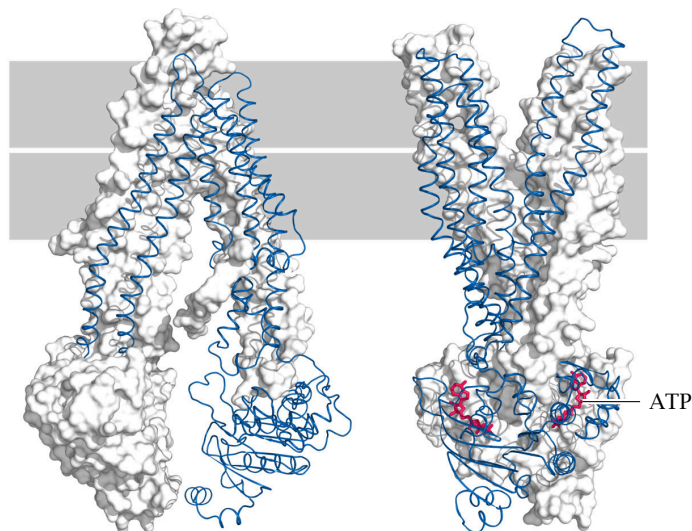

ABC transporters often have rather broad substrate specificity and mediate the membrane translocation of many metabolites and xenobiotics. In addition to cholesterol and other membrane lipids, important examples are bile acids (slide 11.5.3), conjugated bilirubin (slide 17.4), drugs, and drug metabolites (18.1.3).

Cancer cells often overexpress ABC transporters, which renders them resistant to multiple anticancer drugs.

11.4.6 ABC transporters induce substrate “flip-flop” across the membrane

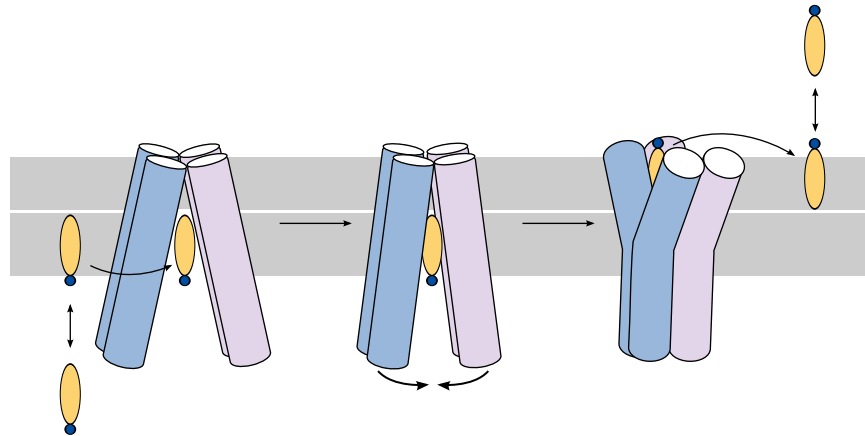

Notes: One feature that is shared by many ABC transporter substrates is their amphiphilic nature. Most ABC transporters expel their substrates from the cytosol to the extracellular space. In this case, the substrate initially resides within the inner leaflet of the cytoplasmic membrane. Once it enters the inward-open conformation of the transporter, the latter undergoes a transition to the outward-open conformation, which is powered by the hydrolysis of ATP. The substrate then leaves the transporter and diffuses into the outer membrane leaflet, from where it may distribute to other extracellular reservoirs.

11.4.7 Transport of cholesterol between the liver and peripheral tissues

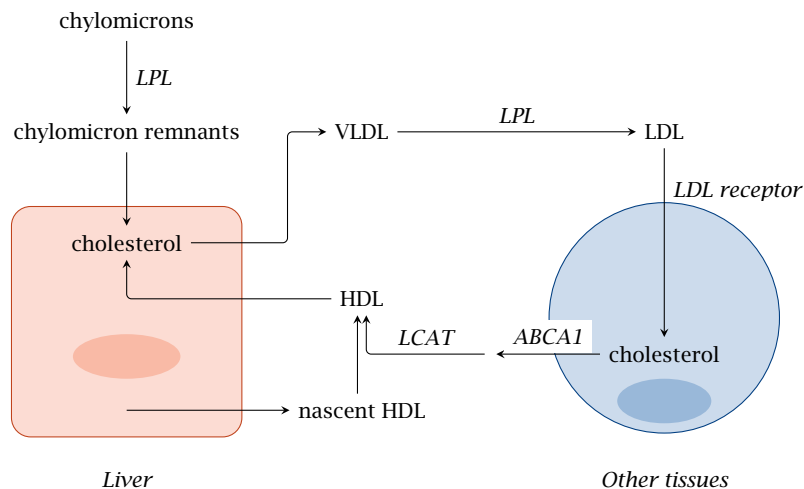

Notes: The liver synthesizes cholesterol from acetyl-CoA (section 11.2). The cholesterol pool in liver cells also receives the dietary cholesterol, which is contained in

the chylomicron remnants that are formed through the extraction of triacylglycerol from chylomicrons by lipoprotein lipase (LPL; slide 10.2.6).

Liver cells package esterified cholesterol, together with triacylglycerol, into particles of very low density lipoprotein (VLDL). Like chylomicrons, VLDL interacts with lipoprotein lipase and thereby turns into intermediate (IDL) and then low density lipoprotein (LDL).

LDL is taken up by cells in the periphery through endocytosis, which is mediated by the LDL receptor.³ Excess cholesterol is exported from the cell by an active transporter (ABCA1) and delivered to high density lipoprotein (HDL), which then carries it back to the liver. Cholesterol transport by HDL is facilitated by lecithin-cholesterol acyltransferase (see next slide).

11.4.8 The lecithin-cholesterol acyltransferase (LCAT) reaction

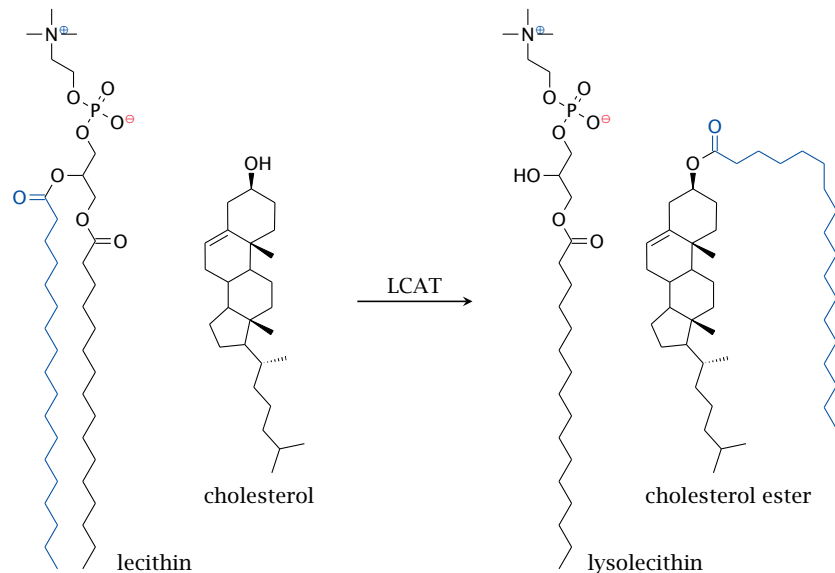

Notes: The HDL particle contains the enzyme lecithin cholesterol acyltransferase, or LCAT for short, which converts cholesterol to cholesterol esters.

The LCAT reaction occurs at the surface of HDL particles. The transfer of one acyl chain from a lecithin (phosphatidylcholine) molecule to cholesterol produces a cholesterol ester and lysolecithin. The significance for cholesterol transport is illustrated in the next slide.

Cholesterol also undergoes esterification as it is packaged into chylomicrons and VLDL inside intestinal and liver cells, respectively. In these cases, acyl-CoA serves as the donor of the acyl residue (see slide 11.4.3).

³LDL manages to leave the circulation by *transcytosis*, that is, endocytosis by the vascular endothelial cells on the luminal side, followed by exocytosis on the opposite side.

11.4.9 Cholesterol esters can be stored inside lipoprotein particles

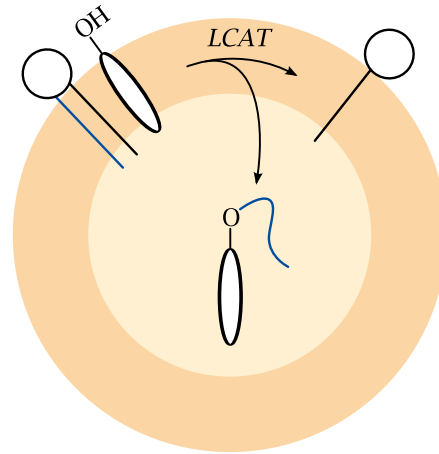

Notes: Cholesterol is amphiphilic and tends to accumulate at lipid/water interfaces, with the OH group exposed to the aqueous phase. Free cholesterol can therefore be transported only within the outermost layer of lipid molecules of a lipoprotein particle. In contrast, cholesterol esters are entirely hydrophobic and readily partition into the interior of lipoprotein particles. The LCAT reaction therefore greatly increases the transport capacity of HDL particles for cholesterol.



11.8 Explain the LCAT reaction and its role for cholesterol transport.

11.5 Bile acid metabolism and transport

Bile acids are the quantitatively most important derivatives of cholesterol. Aside from their essential role in fat digestion, they are also required to keep hydrophobic constituents of the bile in solution, such as unconjugated bilirubin (see section 17.4) and cholesterol itself.

11.5.1 Bile acids are derived from cholesterol

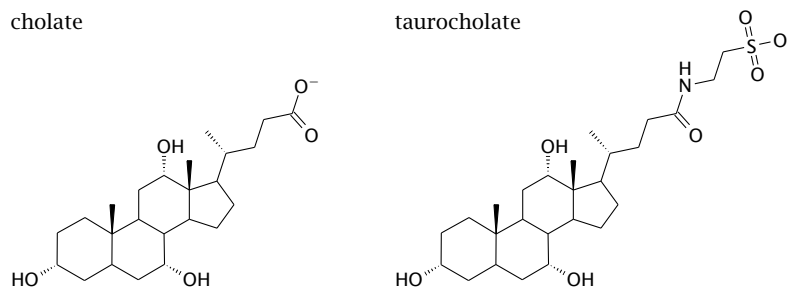

Notes: Cholic acid and some other bile acids are synthesized from cholesterol in the liver. Taurocholate is produced through conjugation of cholate with taurine; similarly, glycocholate is produced through conjugation with glycine.



11.9 What kinds of molecules are derived from cholesterol in human metabolism? Which derivatives are quantitatively the most important ones?

11.5.2 Bile acids undergo enterohepatic cycling

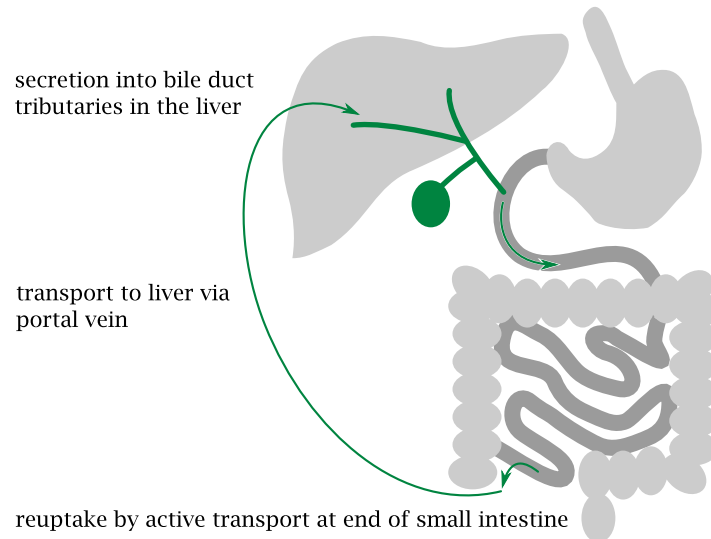

Notes: In an *enterohepatic cycle*, a substance is secreted by the liver into the bile, passes into the intestine and is taken up again into the blood, either by passive diffusion across cell membranes or by active transport. Since blood drained from the intestines feeds into the portal vein, the substance will return to the liver, where it may be captured by liver cells and once again secreted into the bile.

Bile acids are taken up by active transport in the terminal ileum, that is, in the lowermost section of the small intestine. The efficiency of reuptake is normally > 90%. Only the fraction that is not recovered needs to be replaced by *de novo* synthesis from cholesterol.

During their repeated passages through the intestine, some bile acids undergo modification by microbial enzymes; an example is the formation of deoxycholate from cholate. Such modified molecules become part of the circulating bile acid pool.

11.5.3 Bile acid cycling involves multiple transport proteins

Notes: A variety of transport proteins enable the bile acid enterohepatic cycle. Secretion from the liver cell into the bile is driven by ABCB2, another ABC type transporter (compare slide 11.4.5). Reuptake from the lumen of the gut is mediated by the *apical sodium-coupled bile acid transporter* (ASBT). A similar transporter, the *Na⁺-dependent taurocholate cotransporting polypeptide* (NTCP), mediates uptake from the blood back into the liver cell. At the basolateral membranes of both intestinal and liver cells, organic anion transport proteins (OATPs), which have a fairly low degree of substrate specificity, participate in bile acid transport.

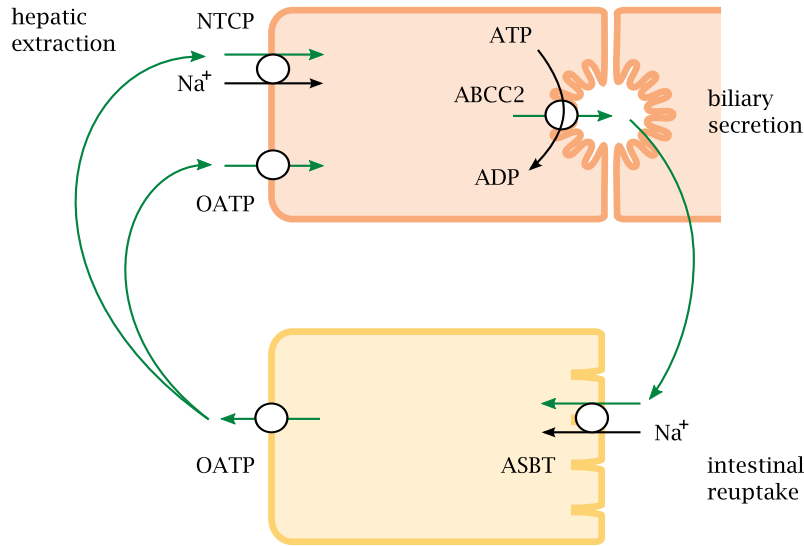

 **11.10** Explain the enterohepatic cycle of bile acids.

11.5.4 A deficient ABCC2 transporter causes Dubin-Johnson syndrome

- impaired excretion of bile acids → cholesterol precipitates in the bile → bile stones
- impaired excretion of bilirubin → jaundice
- impaired excretion of many drugs → potential drug toxicity

Notes: Compared to other hereditary gene defects, this one is relatively frequent. As noted above, the liver can secrete some surplus cholesterol into the bile, where it is kept in solution by bile acids. A shortage of bile acids promotes its precipitation, which ultimately leads to gallstones. However, cholesterol precipitates also tend to form without the transporter defect, and the sterol is indeed the most common gallstone ingredient.

Apart from bile acids, ABCC2 also secretes conjugated bilirubin (bilirubin diglucuronide, see slide 17.4) as well as the conjugated forms of several drugs (section 18.3). In Dubin-Johnson patients, the retention of bilirubin leads to jaundice, whereas the reduced rate of drug elimination increases their concentration in the system and can lead to toxicity. Such drug toxicity may be prevented by reducing the dosage, or by using drugs that are mostly eliminated through the kidneys. Overall, with proper management, Dubin-Johnson syndrome is not very severe.

11.6 Cholesterol and atherosclerosis

11.6.1 Is atherosclerosis a metabolic disease?

... when considering pathogenesis, it is important to remember that the best documented initiating factor in atherogenesis is still hypercholes-

terolemia and that additional factors, of which there are many, should whenever possible be considered in the context of how they relate to the processes initiated by hypercholesterolemia [60].

Notes: This quote sums it up rather well—cholesterol metabolism is a key element in the pathogenesis of atherosclerosis. Another key factor is blood pressure, whose role is illustrated by the simple observation that atherosclerosis afflicts the arteries but not the veins. The accumulation of lymphocytes and macrophages in atherosclerotic lesions highlights the role of inflammation.

In keeping with the scope of these notes, we will here focus on the metabolic causes of atherosclerosis and consider any other factors only in broad outline.

11.6.2 Macroscopic appearance of atherosclerotic lesions

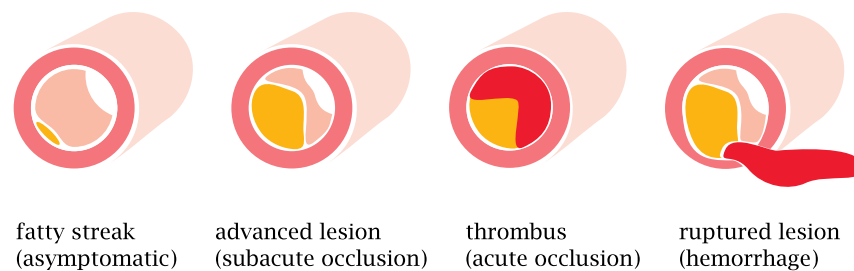

Notes: The earliest readily visible atherosclerotic lesion is the *fatty streak*. It forms within the wall of an artery, in the thin layer of connective tissue that is located underneath the *endothelium* (the innermost cell layer of any blood vessel) and atop the thick layer of smooth muscle that maintains the wall tension and blood pressure.

Fatty streaks are very common—they will be found in the arteries of virtually any middle-aged to elderly person. As such, a fatty streak does not constitute a problem. However, it tends to progress to more serious stages with time. These advanced lesions wreak havoc in various ways:

1. Once they become large, they will constrict the lumen of the artery and hence reduce the blood flow.
2. The endothelium atop an advanced lesion may erode. An intact endothelium inhibits blood clot formation; endothelial lesions bring the blood into contact with tissues and molecules that promote blood coagulation. A blood clot, or *thrombus*, that forms atop such an eroded lesion will cause acute occlusion of the artery. This is what happens in myocardial infarction and in most cases of stroke.
3. An advanced lesion may damage not only the endothelium but also the muscular layer of the arterial wall, which may then rupture. Approximately 20% of all cases of stroke arise in this manner.

Atherosclerosis is a systemic disease. While most commonly manifest in the heart and the brain, vascular occlusion and infarction can strike anywhere and

everywhere; for example, constriction of arteries in the legs causes leg muscle pain even under light exercise (walking), which is known as *intermittent claudication*.⁴

11.6.3 Microscopic appearance of atherosclerotic lesions

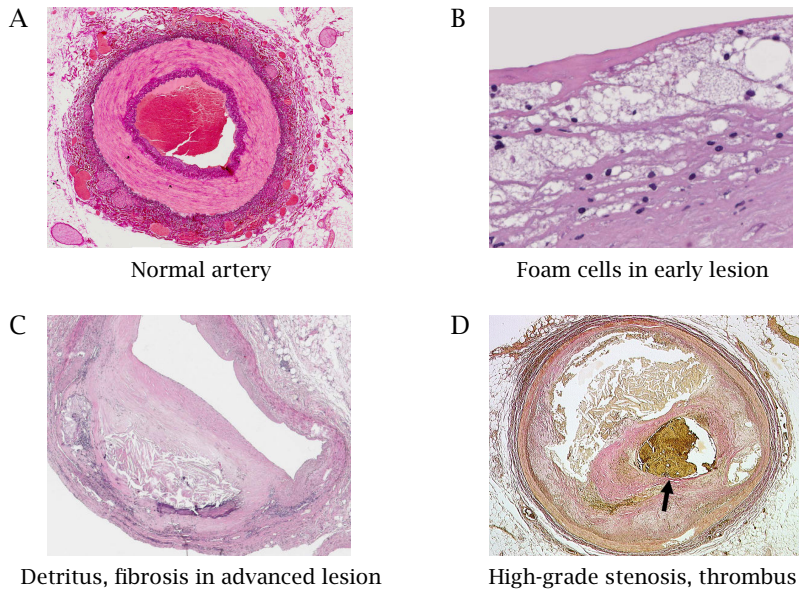

Notes: This slide shows cross sections of a normal artery (A) and of atherosclerotic lesions in different stages of advancement (B–D). The normal artery displays inner and outer layers of connective tissue, stained in dark purple, as well as a strong intermediate muscular layer that shows up in a lighter shade. The endothelium is too thin to be discerned at this low power of magnification. The blood clot in the lumen is a post-mortem artifact.

Panel B shows a higher power view of an early lesion. The bubbly appearance is due to *foam cells*, which are macrophages stuffed chock-full with lipids.⁵ Panel C shows an advanced lesion with connective tissue proliferation and accumulation of detritus within the vessel wall; the lumen of the artery is considerably constricted. Panel D shows an artery that was already almost completely obliterated by a proliferating lesion that had encompassed the entire circumference; the narrow residual lumen is blocked by an acutely formed thrombus (stained yellow-brown).

⁴The German vernacular name for this condition translates as “window shopping disease”—not uncommonly, afflicted patients stop before every window display, feigning interest, in order to disguise their predicament.

⁵The appearance of empty “bubbles” inside the foam cells is an effect of the tissue fixation and staining technique: Organic solvents used in fixation wash out lipids, and most histological dyes bind to proteins or nucleic acids but not lipids.

11.6.4 Development of an atherosclerotic lesion

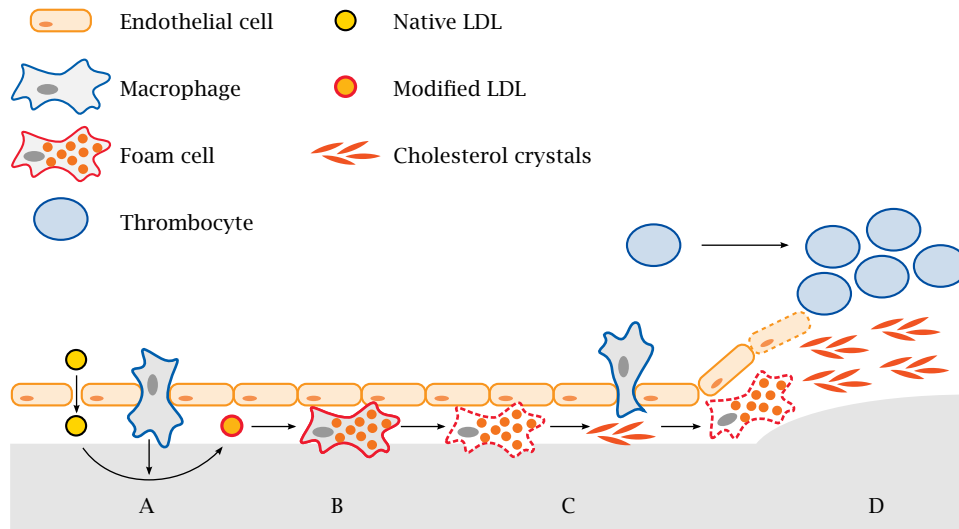

Notes: This slide summarizes the developmental stages of an atherosclerotic lesion. A key role is played by low density lipoprotein (LDL), a specific type of plasma lipoprotein particles that is rich in cholesterol (see slide 11.4.2).

- (A) High blood pressure promotes the formation of small defects in the endothelium. These initial lesions allow blood plasma carrying LDL to seep into the subendothelial tissue; this is followed by transmigration of macrophages. Reactive oxygen species and enzymes released by macrophages modify the LDL.
- (B) Modified LDL is taken up by macrophages. Lipid overload turns macrophages into foam cells.
- (C) Foam cells perish, disintegrate and release the accumulated cholesterol, which forms crystalline deposits. These crystals activate new macrophages and cause them to release inflammatory cytokines that further incite and amplify the inflammation [61].
- (D) In an advanced lesion, cells in the muscular layer proliferate, progressively constricting the artery. When the endothelium that covers the lesion becomes eroded, thrombocytes and plasmatic coagulation factors are activated and initiate blood clotting, causing acute thrombus formation and obstruction.

As an alternative to thrombus formation, acute failure of a damaged artery can also occur through rupture. As stated above, approximately 20% of all cerebral infarctions are caused by rupture and hemorrhage rather than thrombotic occlusion. Hemorrhage is less common in other organs.

The proinflammatory activity of cholesterol crystals echoes that of other crystalline deposits with different chemical composition, such as urate crystals in gout [62] and silica crystals in silicosis (miner's lung). Intracellular signaling complexes called *inflammasomes* are involved in the reaction in each case.



11.11 Explain the origin and significance of foam cells in atherosclerotic lesions.

11.6.5 Metabolic aspects of atherosclerosis

- cholesterol uptake, synthesis and degradation
- cholesterol transport in the circulation: LDL (low density lipoprotein) and HDL (high density lipoprotein)
- biochemical changes that turn physiological, benign LDL into an atherogenic agent

11.6.6 Two modes of uptake of cholesterol into macrophages

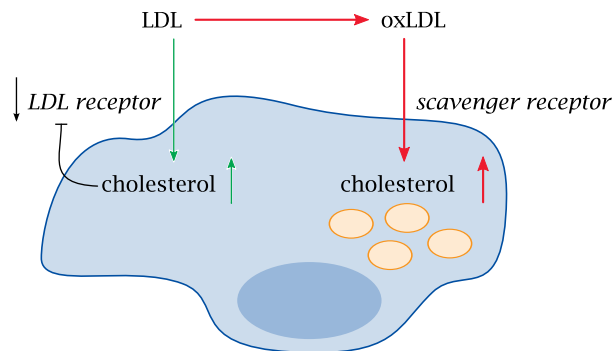

Notes: With macrophages as with other cell types, uptake of native LDL via the LDL receptor is regulated by negative feedback, which lets the cells avoid cholesterol overload. The downregulation of the LDL receptor is achieved by transcriptional regulation via the SREBP/SCAP pathway (section 11.3).

In contrast to other cells, however, macrophages also have so-called *scavenger receptors*, through which they bind and ingest various kinds of debris. Scavenger receptors do not take up native LDL and are not subject to cholesterol-dependent regulation. Oxidized or otherwise modified LDL, however, does enter via the scavenger receptors, which induces cholesterol overload and transforms the macrophages to foam cells. This is a crucial step in the pathogenesis of atherosclerosis.

11.6.7 Experimental modifications that turn LDL into a ligand for the scavenger receptor

Notes: In order to better understand what processes might turn LDL into a scavenger receptor ligand, various types of chemical modifications have been applied in vitro. All of the experimental modifications shown here affect the amino groups of the protein component of LDL (apolipoprotein B). They do not mimic oxidation; therefore, these findings show that LDL oxidation is not the only mechanism that may cause pathologically increased uptake of cholesterol into macrophages. Some, but not all of these modifications are likely to occur in vivo.

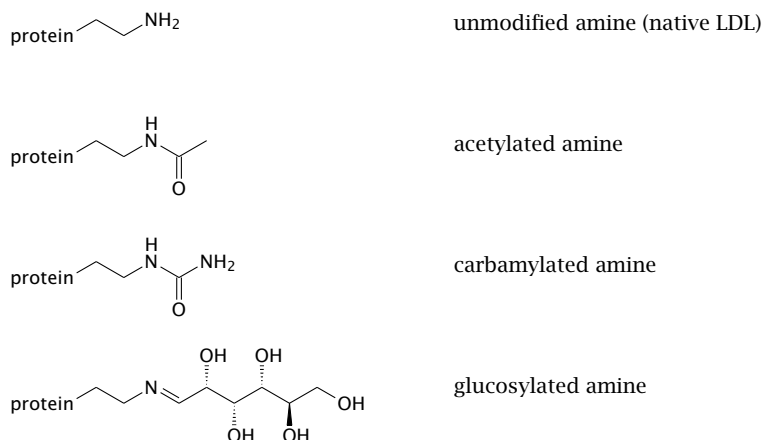

11.6.8 Which modifications of LDL are significant in vivo?

Notes: Oxidized LDL has been demonstrated inside atherosclerotic lesions. Oxidation is widely considered to be the most important single mechanism of LDL modification. It is, however, not very well characterized in molecular terms, and the relative importance of protein and lipid oxidation is not clear.

Modification	Possible causes
acetylation	easily achieved in vitro, but not plausible in vivo
carbamylation	promoted by urea, which is enhanced in kidney disease; also promoted by smoking
glucosylation	promoted by high blood glucose (diabetes)
partial proteolysis	proteases released from macrophages
oxidation of lipids and apolipoproteins	reactive oxygen species released from macrophages

Carbamylation is due to the reaction of amino groups with isocyanate ($\text{HN}=\text{C}=\text{O}$), which arises through isomerization from urea. Isocyanate apparently also forms from isothiocyanate ($\text{HN}=\text{C}=\text{S}$) through oxidation, and it has been proposed that this mechanism promotes atherosclerosis in smokers [63].

Glucosylation is likely increased in diabetes and may contribute to the observed acceleration of atherosclerosis in diabetic patients, although it will be difficult to separate this effect from that of other metabolic consequences of diabetes such as hyperlipidemia. The mechanism of glucosylation is the same as with that of hemoglobin (see section 14.5.8).

Proteases are released by inflammatory cells, which occur in atherosclerotic lesions; therefore, partial proteolytic degradation is another mechanism that is plausible in vivo [64].



11.12 What is the significance of LDL modifications in the development of atherosclerosis? Which types of pathogenic modifications of LDL have been characterized?

11.6.9 How does LDL become oxidized?

- Transition metals (Fe, Cu) convert O_2 to reactive oxygen species: hydrogen peroxide (H_2O_2), superoxide ($\bullet O-O^-$)
- Macrophages produce reactive oxygen species
- Lipoxygenases produce lipid hydroperoxy-radicals that can bind to LDL and induce lipid peroxidation
- Myeloperoxidase produces hypochlorite (HOCl)

Notes: The formation of reactive oxygen species (ROS) catalyzed by transition metals is common; it is not restricted to atherosclerotic lesions but also occurs for example in mitochondrial respiration. However, activated macrophages likely cause more ROS formation than vagrant transition metals.

Lipoxygenases attach molecular oxygen to arachidonic acid and similar polyunsaturated fatty acids. The peroxy radicals thus generated can then associate with LDL and set off a self-sustaining cycle of lipid peroxidation (see below).

The reaction of H_2O_2 with chloride ions generates bleach (HOCl), which can react with tyrosine residues. This reaction is catalyzed by myeloperoxidase and is important in antimicrobial defense. However, its contribution to the development of atherosclerotic lesions seems questionable.

11.6.10 Self-sustained lipid peroxidation induced by peroxy radicals

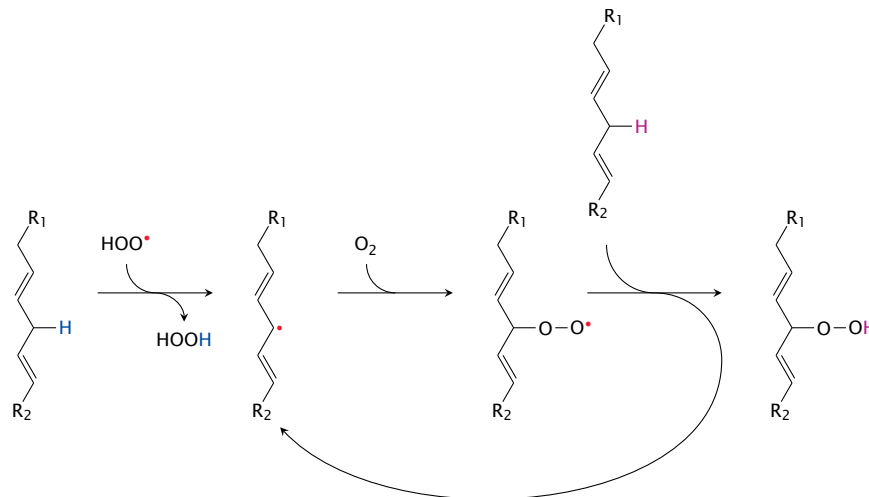

Notes: Lipid peroxidation is initiated by a radical. This can be a hydroperoxy radical, as shown here, or an even more reactive hydroxy radical, which can form from superoxide ($O_2^{\bullet-}$) in the presence of transition metals. The radical steals a hydrogen from a methylene group of an unsaturated fatty acyl residue, which is thereby turned into a radical itself and sets off a self-sustaining cycle of lipid

peroxidation that requires nothing more than further unsaturated fatty acids and molecular oxygen.

The peroxidation can also begin with lipid peroxy radicals that are formed by lipoxygenases, which produce such molecules as precursors of leukotrienes and other mediators of inflammation. Lipoxygenase inhibitors have shown some potential to slow down atherosclerosis in animal models; however, it is difficult to determine how much of that benefit is due to reduced oxidation of LDL, as opposed to the inhibited signaling by proinflammatory mediators.

The same process of lipid peroxidation also occurs in cell membranes. This is important in various diseases. An example is *favism*, a condition in which the failure to neutralize reactive oxygen species causes the destruction of red blood cells (see slide 9.4.2).



11.13 How does autocatalytic lipid peroxidation occur, and where does it matter in the pathogenesis of atherosclerosis?

11.6.11 α -Tocopherol intercepts lipid peroxidation

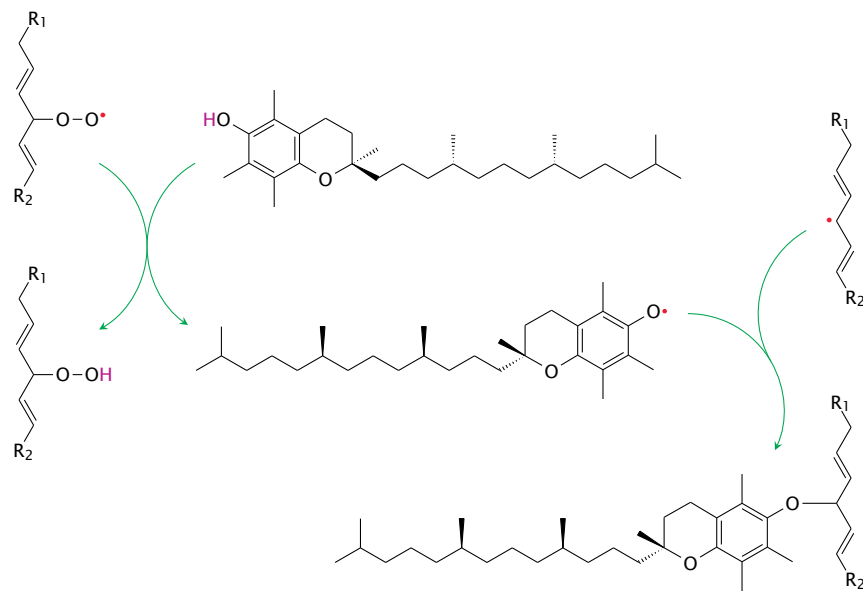

Notes: Various antioxidants can intercept the autocatalytic process of lipid peroxidation. Particularly effective are α -tocopherol and related compounds, which collectively are referred to as vitamin E, and which due to their fat-soluble nature are enriched in cell membranes.

You may have noticed that generous amounts of vitamin E are routinely added to vegetable oil and lard. This is not done out of concern for your health; rather, the rationale is to protect these foods from turning rancid through peroxidation of their unsaturated fatty acids.

11.6.12 Experimental evidence implicating LDL oxidation in the pathogenesis of atherosclerosis

- Vitamin E reduces the severity of atherosclerosis in animal models—but *not* in clinical studies on humans
- Antibodies against oxidized LDL are found in blood; among these, IgG promotes atherosclerosis, whereas IgM inhibits it
- *Haptoglobin* alleles differ in the efficiency of hemoglobin clearance, which correlates inversely with susceptibility to atherosclerosis
- Production of HOCl by myeloperoxidase: Chlorotyrosine residues detectable in oxLDL *ex vivo*—but myeloperoxidase k.o. mice have *increased* susceptibility to atherosclerosis

Notes: Regarding vitamin E: It never ceases to amaze me how many therapies that work wonders in mice fall flat when applied to humans. Too bad we aren't mice ... maybe after all Douglas Adams [65] was right about who was running the show between man and mice?⁶

The effect of antibodies to oxidized LDL may be due to *opsonization*: antibody-decorated particles are taken up more efficiently by phagocytes, which have receptors for antibodies on their surface. Since there are receptors for both IgG and IgM, I'm not sure what to make of the observed difference between the two types of antibodies on atherosclerosis progression. In any case, the observation that antibodies have any effect at all suggests that their antigen matters.

Haptoglobin is a serum protein that captures hemoglobin released from decayed erythrocytes. In adults, the regular turnover of red blood cells releases several grams of hemoglobin every day. If free hemoglobin is not promptly cleared, it may shed heme, which then may bind to LDL and promote its oxidation [66]. Haptoglobin genotypes are associated with the risk to suffer from complications of atherosclerosis [67].

Myeloperoxidase produces HOCl from H₂O₂. While oxidation of LDL by HOCl may promote LDL phagocytosis, the effect of genetic myeloperoxidase knockout suggests that HOCl is less effective in this regard than the H₂O₂ consumed in its formation would have been.

11.7 Cholesterol metabolism and the treatment of atherosclerosis

11.7.1 Lowering LDL cholesterol: therapeutic principles

- inhibition of cholesterol synthesis
- inhibition of cholesterol uptake
- inhibition of cholesterol ester transfer protein

⁶Of note, Adams died at 49, only a few years after finishing his book “The Hitchhiker’s Guide to the Galaxy,” in which he exposed the far-ranging conspiracy of mice. It would seem that the mice exacted their revenge!

- inhibition of bile acid reuptake
- LDL apheresis

Notes: Lowering cholesterol is a key objective in the clinical management of atherosclerosis. Based on the foregoing, we can appreciate the strategies listed here. Two or more of these strategies are often used in combination.

11.7.2 “Statins” inhibit HMG-CoA reductase

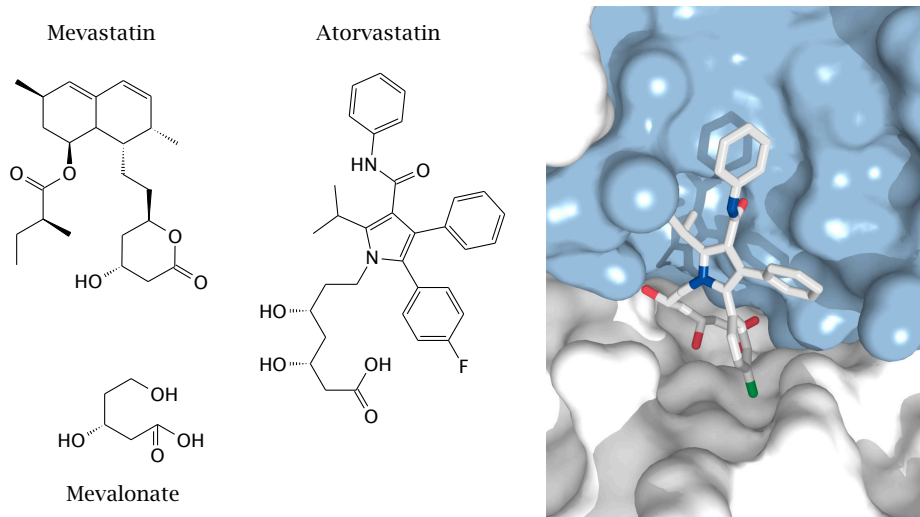

Notes: Inhibition of HMG-CoA reductase is currently the single most effective and widely used strategy to lower plasma cholesterol. The first inhibitor was mevastatin, a natural compound isolated from the fungus *Penicillium citrinum*. Its function in nature is probably to inhibit the growth of competing fungal species by blocking their synthesis of ergosterol, which also requires HMG-CoA reductase.

Some early therapeutically useful statins, such as lovastatin, were derived from mevastatin. Modern statins such as atorvastatin depart from the mevastatin structure. However, both mevastatin and atorvastatin contain a moiety resembling the product of the enzyme reaction (mevalonate).

HMG-CoA reductase has four subunits, with four active sites located at subunit interfaces. The picture shows one active site confined between two subunits, which are rendered in white and blue, respectively. An atorvastatin molecule occupies the active site. Rendered from [1hwk.pdb](#).

11.7.3 Inhibitors of intestinal cholesterol uptake

Notes: Inhibitors of intestinal cholesterol absorption represent another plausible strategy to lower plasma cholesterol, but their effect on blood cholesterol levels is less powerful than that of the statins.

Ezetimibe binds to the NPC1L1 protein in the luminal cell membrane (slide 11.4.3) and inactivates it. The drug is used mostly in conjunction with statin drugs.

The β -lactam ring in the center of the structure is likely reactive, which suggests that ezetimibe may bind its target covalently, but I have not found experimental evidence supporting this assumption.

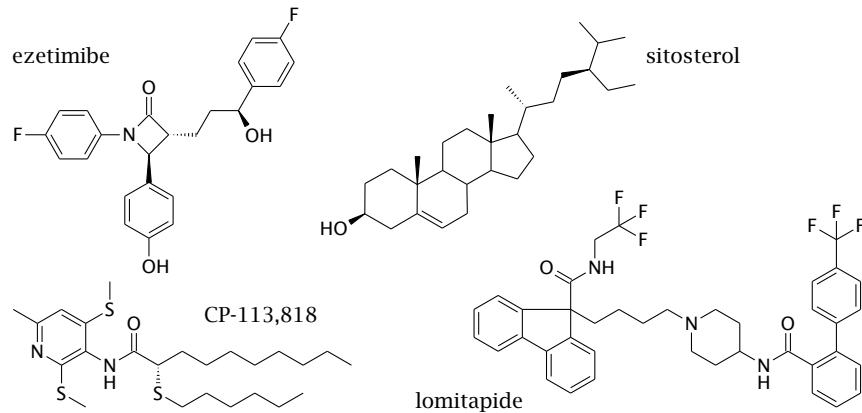

Lomitapide inhibits the transfer of cholesterol from endocytotic vesicles to the ER by mitochondrial triglyceride transfer protein (MTTP). At the ER, cholesterol is normally converted to cholesterol esters by ACAT. CP-113,818 is an experimental inhibitor of ACAT. These two strategies are currently still experimental.

Sitosterol and other plant sterols compete with cholesterol for intestinal uptake. This “low tech” strategy is clinically proven yet has modest benefits.

11.7.4 Cholesterol ester transfer protein (CETP) short-circuits cholesterol transport by lipoproteins

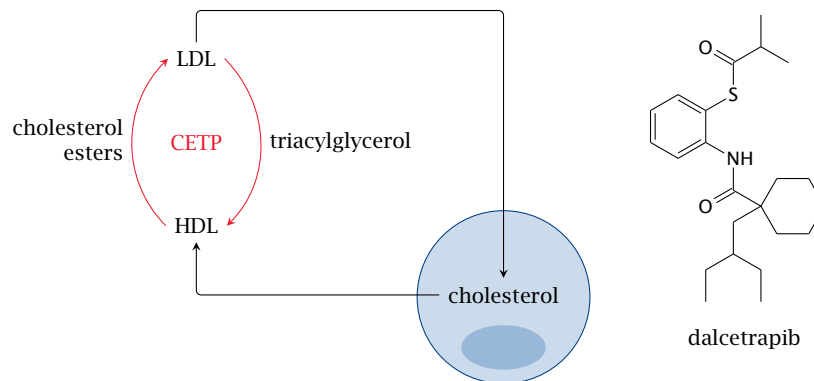

Notes: CETP, a serum protein, facilitates the exchange of triacylglycerol and cholesterol esters between HDL and LDL. The net effect seems to be an increase of LDL cholesterol, and accordingly inhibition of CETP looks like a promising strategy.

Dalcetrapib is one of several CETP inhibitors that have been or currently are under study by various pharmaceutical companies. While dalcetrapib indeed raises the ratio of HDL cholesterol to LDL cholesterol, large scale clinical trials have been put on hold due to lack of improvement in clinical outcomes [68].

11.7.5 Cholestyramine particles absorb bile acids

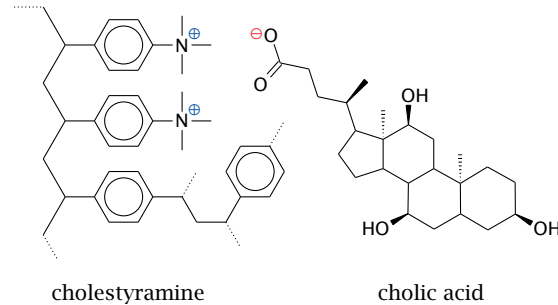

Notes: Cholestyramine and similar polymers adsorb bile acids due to a combination of electrostatic and hydrophobic forces. This prevents the bile acids from being taken up at the end of the small intestine. They are replaced by *de novo* synthesis from cholesterol, which therefore depletes the pool of cholesterol in the liver.

The strategy is effective but has some side effects. The concentration of bile acids in the bile is reduced; this promotes precipitation of cholesterol and other poorly soluble bile constituents, which may then form gallstones. The polymer particles may also bind some drugs or fat-soluble vitamins and prevent their absorption.

11.7.6 LDL apheresis

- Blood is diverted through an extra-corporeal filtration device
- cells are separated from plasma
- LDL is removed from plasma by affinity methods or size-based filtration
- The remaining plasma and cells are returned to the circulation
- The procedure is repeated in weekly or biweekly intervals

Notes: While conceptually simple, LDL apheresis is involved and time-consuming in practice. It is therefore used only in severe cases, such as homozygous familial hypercholesterolemia.

11.7.7 More ...

- triparanol—an old drug, inhibits some CYP450 enzymes in the conversion from lanosterol to cholesterol; withdrawn due to toxicity
- bezafibrate—a PPAR γ agonist
- nicotinic acid—activates hormone-sensitive lipase through a G protein coupled receptor named HM74A; 5 likely additional mechanisms
- probucol and succinobucol—supposedly antioxidants that prevent LDL oxidation, but also cause unrelated changes in other laboratory parameters

- guar gum and other carbohydrate fibers —absorb and prevent intestinal uptake of cholesterol and bile acids with variable efficiency
- thyroid hormone analogs—promote LDL utilization

Notes: We will not cover these drugs in detail, but you may find it interesting to look them up in the literature yourself.

 **11.14** Explain the major therapeutic strategies for lowering LDL cholesterol.

11.8 Gene defects in cholesterol transport and metabolism

11.8.1 Familial hypercholesterolemia is due to a gene defect in the LDL receptor

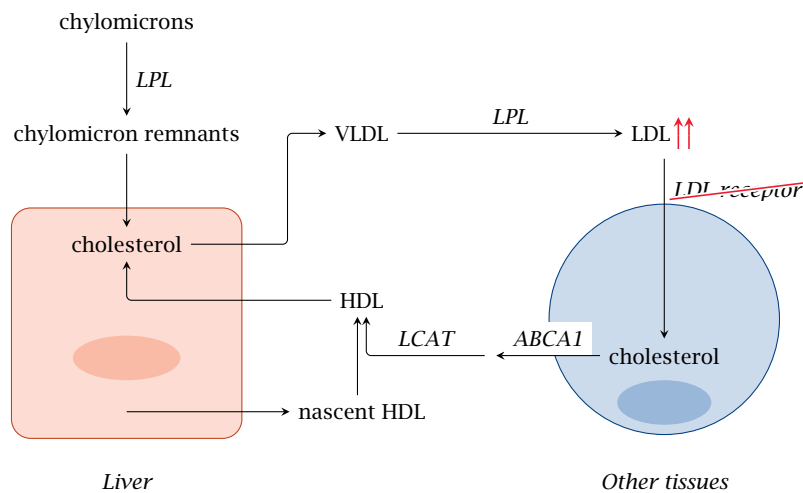

Notes: In Caucasians, this gene defect occurs with a heterozygote frequency of 1 in 500. While most other hereditary defects of metabolism are clinically manifest only in homozygous form, familial hypercholesterolemia is symptomatic in both heterozygous and homozygous individuals, and therefore much more commonly encountered in clinical practice.

The defect is more severe in homozygous patients, whose levels of LDL in the blood are several times higher than normal. Before effective treatment options became available, these patients used to develop severe atherosclerosis at young age, leading to death due to myocardial infarction or stroke by the age of 40 years or earlier. This situation has improved through therapy with statin drugs and LDL apheresis.

 **11.15** What is the underlying defect in familial hypercholesterolemia? What are the consequences?

11.8.2 Tangier disease: Disruption of cholesterol transfer to HDL

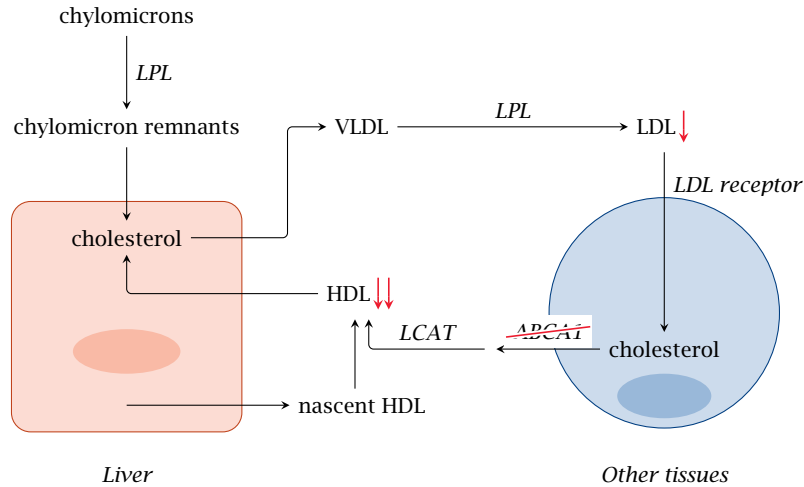

Notes: Tangier disease, which is very rare, is interesting from a mechanistic point of view. The defect concerns the ABC transporter that exports surplus cholesterol from the cell for delivery to HDL. As a consequence, HDL is greatly reduced. Interestingly, LDL cholesterol is also reduced; this may be due to the transfer of cholesterol between LDL and HDL mediated by CETP (see slide 11.7.4).

Fatty deposits are found in the liver, spleen and cornea. Patients develop atherosclerosis, type 2 diabetes, and neuropathy.

11.8.3 A defective plant sterol exporter causes sitosterolemia

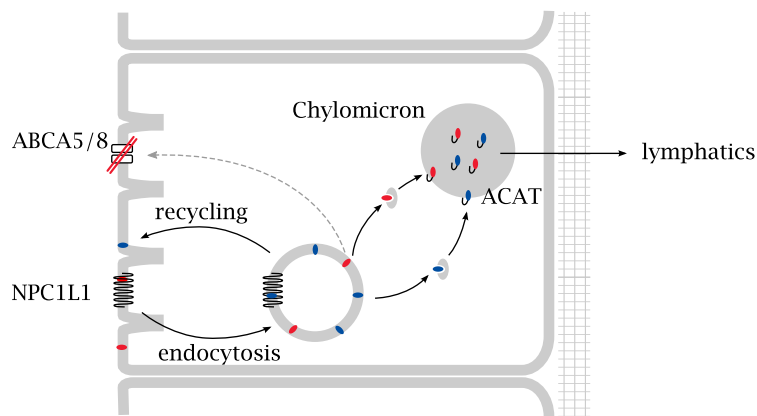

Notes: Genetic deficiency of the ABCA5/8 transporter results in *sitosterolemia*. Plant sterols that are taken up from the gut lumen can no longer be extruded, accumulate inside the mucosal cells, and ultimately find their way into the chylomicrons and the system. Patients have very high levels of plant sterols in the plasma; they develop lipid deposits in the skin and atherosclerosis.

In these patients, therapeutic application of plant sterols in order to inhibit cholesterol uptake would obviously be a bad idea. The treatment of choice is ezetimibe [69, 70], which inhibits the NPC1L1 protein (see slide 11.7.3).

11.9 Answers to practice questions

11.1: Dietary sources are meat and animal products only. We do not require dietary cholesterol, since our own biosynthetic capacity can cover our metabolic needs.

11.2: The conversion of hydroxymethylglutaryl-CoA to mevalonate by HMG-CoA reductase.

11.3: Cytochrome P450 enzymes catalyze the formation of lanosterol from the last linear precursor, squalene, and several subsequent demethylation and desaturation steps.

11.4: 1. Immediate biosynthetic precursor of cholesterol 2. Precursor of cholecalciferol, which is formed from 7-dehydrocholesterol through a photochemical reaction in the skin

11.5: A regulatory DNA motif, the *sterol response element* (SRE), is found upstream of the HMG-CoA synthase gene and related genes. It is activated by SREBP, a protein that starts life as a membrane protein in the ER. If cholesterol in the ER membrane is low, SREBP is bound by SCAP, which is sorted to the Golgi apparatus, where SREBP is proteolytically cleaved and released from the membrane. SREBP then translocates to the nucleus, where it binds SRE and activates transcription.

11.6: Cholesterol is taken up on the apical side of the epithelial cells by endocytosis, which is under the control of the NPC1L1 protein. Cholesterol is transferred by a sterol carrier protein from the endocytotic vesicles to the ER, where it is converted to a cholesterol ester by ACAT and then packaged into nascent chylomicrons.

11.7: They compete with it at the initial stage (NPC1L1-mediated endocytosis). After endocytosis, they are expelled back into the intestine by a dedicated ABC transporter.

11.8: The LCAT reaction transfers one of the two acyl chains from lecithin to cholesterol, producing lysolecithin and a cholesterol ester. Unlike free cholesterol, cholesterol esters can partition into the interior of lipoprotein particles. They can therefore be transported in greater amounts than free cholesterol, which is restricted to the surface of the particles.

11.9: Steroid hormones and bile acids. The latter ones are made in greater amounts.

11.10: Bile acids are secreted into the bile by liver epithelial cells. After traveling down the intestinal lumen, they are taken up by specific active transport in the lowermost section of the small intestine. The extent of reuptake is above 90%. They reach the liver via the portal vein and are again extracted from the blood and secreted by the liver epithelia.

11.11: Foam cells are macrophages that have ingested modified LDL. The “bubbles” inside a foam cell contain cholesterol and cholesterol esters that were contained in the LDL. When a foam cell dies, these lipids are released into the extracellular space, where they precipitate or crystallize. This sustains and perpetuates the inflammatory process.

11.12: Different chemical modifications of LDL result in the uptake of the modified LDL particles into macrophages via the scavenger receptor. Since this uptake is not subject to feedback inhibition, the macrophages become overloaded with cholesterol and transform into foam cells.

Modifications that have been found to have this effect include oxidation, which affects mostly lipids, as well as enzymatic degradation and chemical reactions such as glucosylation and carbamylation, which affect mostly the apolipoproteins.

11.13: The reaction is initiated by superoxide, which abstracts an electron from a double bond in an unsaturated fatty acid. The fatty acyl radical produced reacts with molecular oxygen, which produces a peroxy radical that can engage in the same reaction as superoxide and thus perpetuate the cycle.

Lipid peroxidation can affect LDL and contribute to its oxidation. Oxidized LDL is taken up by macrophages in atherosclerotic lesions and induces their transformation into foam cells.

11.14: 1. Inhibition of HMG-CoA reductase, the rate-limiting step of cholesterol synthesis
2. Depletion of bile acids with polymer particles (e.g. cholestyramine)
3. Inhibition of intestinal cholesterol uptake, with either plant sterols (sitosterol) or ezetimibe (inhibitor of NPC1L1)

11.15: This condition is due to a genetic defect in the LDL receptor. The excessively high LDL promotes atherosclerosis, which becomes manifest early and severely.

Chapter 12

Amino acid metabolism

12.1 Metabolic uses of amino acids

- building blocks for protein synthesis
- precursors of nucleotides and heme
- source of energy
- neurotransmitters
- precursors of neurotransmitters and hormones

Notes: We have seen before that, during digestion in the gut, proteins are broken down to their constituent amino acids. Proteins contain twenty standard amino acids, which are incorporated into them during translation. Proteins may also contain several non-standard amino acids; these are mostly formed by post-translational modification, and they are much less abundant than the standard amino acids. In this chapter, we will focus on the standard amino acids, although some non-standard ones will appear in the urea cycle.

Animals and humans obtain many important metabolites from their food and have a fairly lazy synthetic metabolism. While many other organisms, even simple ones such as *E. coli*, can make all their amino acids from scratch, we possess synthetic pathways for only 11 out of the 20 standard amino acids. The remaining ones must be obtained from the diet and accordingly are referred to as the essential amino acids.¹ A certain amount of dietary protein is therefore strictly necessary, and the lack of food protein is a very common form of malnutrition in impoverished countries. Nevertheless, during day-to-day protein turnover, most of the amino acids used in protein synthesis are obtained not from food but rather through endogenous protein breakdown; food protein only replaces the fraction of amino acids diverted toward other destinations.

¹These essential amino acids are histidine, isoleucine, leucine, lysine, methionine, phenylalanine, threonine, tryptophan, and valine. Arginine can be synthesized but apparently not always in sufficient amounts, and thus is often listed as the tenth essential amino acid.

In this chapter, we will mostly focus on degradative pathways of amino acids; their synthesis will be touched upon only briefly. The roles of specific amino acids in the synthesis of nucleotides are covered in chapter 16. The use of glycine in the synthesis of heme is discussed in chapter 17.

12.1.1 Outline of amino acid degradation

- The liver is the major site of degradation for most amino acids, but muscle and kidney dominate the degradation of specific ones
- Nitrogen is removed from the carbon skeleton and transferred to α -ketoglutarate, which yields glutamate
- The carbon skeletons are converted to intermediates of the mainstream carbon oxidation pathways via specific adapter pathways
- Surplus nitrogen is removed from glutamate, incorporated into urea, and excreted

Notes: All amino acids contain at least one nitrogen atom, which forms their α -amino group; several amino acids contain additional nitrogen atoms in their side chains. Some nitrogen is used in biosynthesis, for example of nucleotides, but most of it is surplus and must be eliminated. To this end, the liver incorporates it into urea, which is released into the bloodstream and excreted by the kidneys.

Removal of nitrogen is typically an early step in the degradation and leaves behind the carbon skeleton. The structure of the latter is different for each amino acid, and accordingly each amino acid has its own specific pathway of degradation.

12.1.2 Amino acid breakdown pathways join mainstream carbon utilization at different points of entry

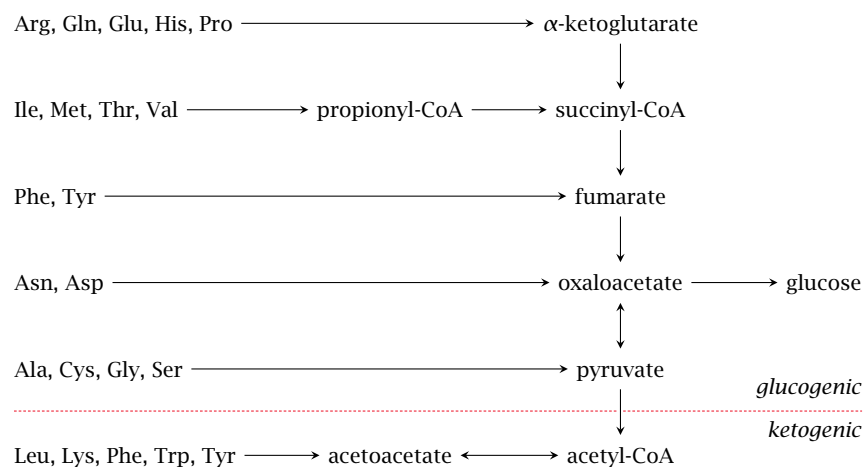

Notes: The degradative pathways can be divided into two major classes. As shown here, most amino acids are converted to intermediates of the citric acid cycle or to pyruvate, which in turn can serve as precursors for gluconeogenesis; these are

the *glucogenic* amino acids. Those amino acids that yield acetoacetate are called *ketogenic*, since acetoacetate is one of the ketone bodies (see slide 10.4).

If you look carefully, you will see that phenylalanine and tyrosine are found on both sides of the divide, since they yield both fumarate and acetoacetate. I suppose that makes them both glucogenic and ketogenic, although some might insist that either category should take precedence; this is merely a matter of definition.

Depending on the composition of our diet, amino acids may be very important as a source of energy. While plant-derived foodstuffs are typically rich in starch, meat is high in protein but low in carbohydrates. Therefore, when on a diet that contains mostly meat, amino acids become our major source of glucose.

What happens if protein is supplied in excess of the amount needed to cover our requirement for glucose? While the liver in principle contains all enzyme activities required to oxidize the surplus carbon, measurements of the liver's overall oxygen consumption indicate that most of the oxidation must happen elsewhere [71]. Presumably, much of the carbon still ends up as glucose, which is then either stored as glycogen or released into the circulation. In the latter case, the surplus will mostly be converted to fat in adipose tissue. A surplus of ketogenic amino acids will mostly be converted to fat in the liver, which is then packaged and released as VLDL (see slide 11.4.2).



12.1 Explain why we need a minimum amount of protein in the diet. Also explain the difference between glucogenic and ketogenic amino acids.

12.2 Transamination of amino acids

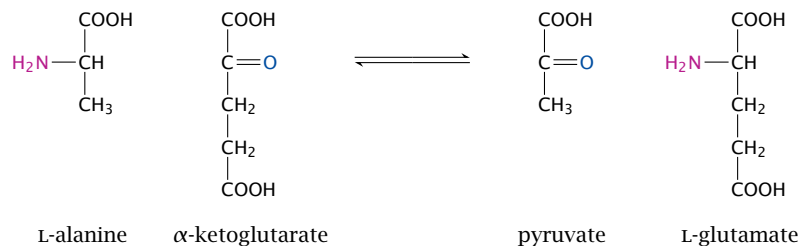

Notes: Most standard amino acids lose their α -amino group early on in degradation through transamination, that is, transfer to an α -keto acid. This is illustrated here for alanine, which transfers its amino group to α -ketoglutarate to become pyruvate.² Transamination is mediated by several different aminotransferase enzymes. These may be specific for individual amino acids, or they may be able to process a group of chemically similar ones. The latter applies to the group of the branched-chain amino acids, which comprises leucine, isoleucine, and valine.

In the case of alanine, the α -keto acid that accepts the amino group is α -ketoglutarate; this also applies to most other amino acids. Transamination is freely reversible; therefore, both glutamate and α -ketoglutarate are substrates of

²Since we already know how to degrade pyruvate, transamination is all that is required to account for the degradation of alanine. Similarly, as we had seen in slide 6.9.2, aspartate is transaminated to oxaloacetate, which again suffices to account for its utilization.

multiple transaminases. If amino groups are to be transferred between two amino acids other than glutamate, this will usually involve the formation of glutamate as an intermediate. The role of glutamate in transamination is only one aspect of its central place in amino acid metabolism (see slide 12.3.7).

12.2.1 The reaction mechanism of transamination

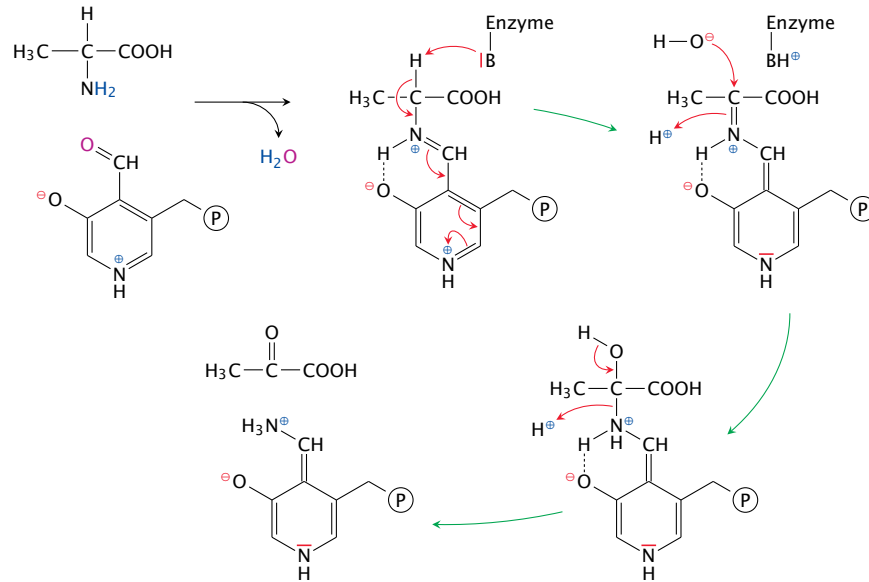

Notes: In this scheme, we again show alanine as the example substrate, but the mechanism is very general. All transaminases employ the coenzyme pyridoxal phosphate (PLP), which is the centerpiece of the reaction mechanism. The aldehyde group of PLP can form an aldimine, or Schiff base, with the α amino group of the substrate, which releases water.³

After binding of the substrate to PLP, a catalytic base in the active site abstracts its α hydrogen as a proton, and the surplus electron left behind travels all the way down to the nitrogen at the bottom of the PLP ring, inverting the entire sequence of single and double bonds along the way. This has the effect of turning the bond between the α carbon and the α nitrogen into a Schiff base, which then undergoes hydrolysis to release pyruvate.

At this point, the reaction is only half complete—the nitrogen is still attached to PLP and needs to be transferred to α -ketoglutarate. The sequence of steps involved in this transfer is the exact reversal of the ones shown here, so we won't show them in detail. However, you might still find it a useful exercise to draw these reaction steps yourself.

It is interesting to compare the transaminase mechanism with that of serine hydroxymethyltransferase (slide 15.2.4). While that enzyme breaks the bond between the α carbon and the side chain rather than the amino group, it uses PLP in

³At the outset, PLP actually forms a Schiff base with a lysine side chain of the enzyme, which is then displaced by the incoming substrate; these steps have been skipped here for simplicity. The liberated lysine then assumes the role of the catalytic base, which is represented here by B.

much the same manner to destabilize the substrate by withdrawing an electron. This also occurs in other PLP-mediated reactions; and in those reactions, PLP is often said to act as an *electron sink*. PLP also serves as a coenzyme in the glycogen phosphorylase reaction; however, its catalytic role there is entirely different (see slide 8.3.6).



12.2 Compare the role of pyridoxal phosphate in amino acid transamination to that in the glycogen phosphorylase reaction.

12.2.2 The *ping pong bi bi* mechanism of transamination

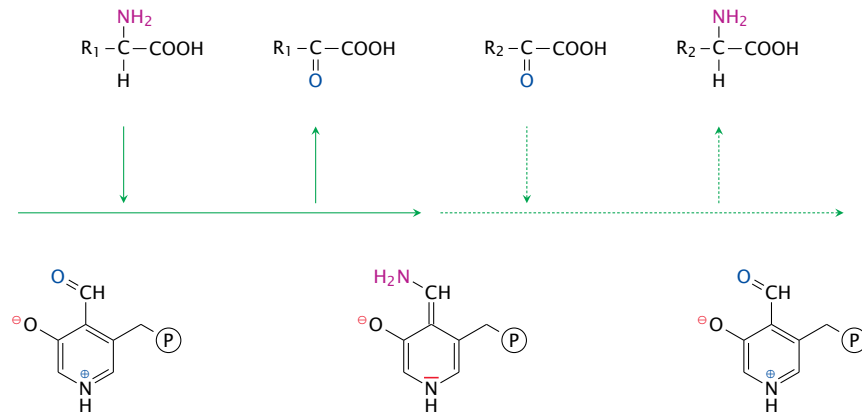

Notes: The interaction of the transaminase with its substrates involves four discrete steps: 1) the first substrate enters, 2) the first product leaves, 3) the second substrate enters, and 4) the second product leaves. Such a strictly sequential order is referred to as a *ping pong* mechanism. A *ping pong bi bi* mechanism is one that, on top of being strictly sequential, involves exactly two substrates and two products.⁴

While two different substrates must be used for the reaction to have some useful effect, it is of course possible for R_1 and R_2 to be identical—the reaction will work just fine, but simply achieve no net turnover.

12.3 Nitrogen disposal and excretion

- Nitrogen accruing outside the liver is transported to the liver as glutamine or alanine
- In the liver, nitrogen is released as free ammonia
- Ammonia is incorporated into urea
- Urea is released from the liver into the bloodstream and excreted through the kidneys

⁴While this bit of nomenclature may be surprising in its nonchalance, we should probably be grateful that it did not fall to some Old World biochemists with classical inclinations to dream up a name for the behavior. The mind boggles at the possibilities—perhaps: Antidromo-binary vacillatory allochronic?

Notes: While transamination solves the problem of removing the α -nitrogen for the amino acids other than glutamate, there also must be mechanisms for regenerating the α -ketoglutarate that is converted to glutamate in each transamination reaction, and for the ultimate disposal of nitrogen. A reaction that directly regenerates α -ketoglutarate is catalyzed by glutamate dehydrogenase, as follows:



While this reaction is straightforward, it produces free ammonia, which is quite toxic and must be kept at low (micromolar) concentrations in the systemic circulation at all times. Therefore, free ammonia is not a suitable medium for ultimate disposal of nitrogen; instead, elimination occurs mostly in the form of urea. The sequence of reactions that incorporates nitrogen into urea is the urea cycle.⁵

The glutamate dehydrogenase reaction is reversible in principle, but the affinity of the enzyme for ammonia is low. Interestingly, this enzyme can utilize both NAD^+ and NADP^+ as cosubstrates. As we have seen (slide 9.3.1), the former is present in the cell mostly in the oxidized form, which would favor the release of ammonia, whereas the latter is mostly found as NADPH , which would favor ammonia fixation. It is not entirely clear what regulatory mechanism, if any, prevents the enzyme from performing both reactions in a cycle, which would simply cause the reduction of NAD^+ at the expense of NADPH .

12.3.1 The urea cycle, part 1: carbamoylphosphate synthetase

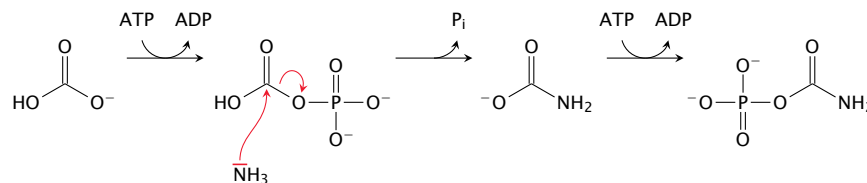

Notes: The urea cycle runs only in the liver. It begins with the incorporation of ammonia into carbamoylphosphate by the corresponding synthetase. This reaction occurs in three successive steps. The first step uses ATP to activate bicarbonate to carbonylphosphate, which then captures free ammonia to form carbamate. Another ATP-dependent step activates that intermediate to carbamoylphosphate. The carbamoyl group will find its way into the urea that is produced by the urea cycle.

⁵In liver cirrhosis, one of the main problems is the lacking capability of the liver to detoxify ammonia derived from bacterial metabolism in the large intestine. Oral antibiotics (e.g. paromomycin) are used in this condition to reduce bacterial growth and ammonia formation.

Some ammonia is excreted with the urine as well, where it serves to buffer surplus protons also destined for excretion. However, this ammonia is not extracted from the circulation but is formed from glutamine directly in the kidneys.

12.3.2 The urea cycle, part 2: subsequent reactions

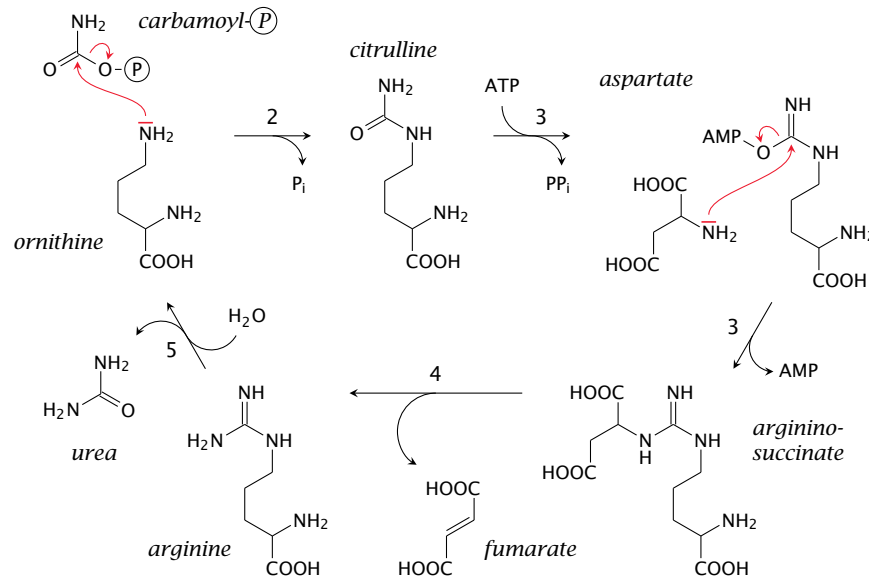

Notes: The subsequent reactions in the urea cycle are as follows:

2. The carbamoyl group is transferred from carbamoylphosphate to the δ -amino group of ornithine, a non-standard amino acid homologous to lysine, by ornithine transcarbamylase. This reaction yields citrulline.
3. Citrulline and aspartate form argininosuccinate, catalyzed by argininosuccinate synthetase. This reaction again requires ATP, which is converted to AMP in the process.
4. Argininosuccinate is cleaved to fumarate and arginine by argininosuccinase.
5. Urea is released from arginine by arginase, which regenerates ornithine and closes the cycle.

You will have noticed that only one of the nitrogens in urea is accounted for by carbamoylphosphate and, therefore, ammonia. The overall reaction of the urea cycle is

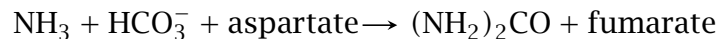

with the additional expenditure of several equivalents of ATP in order to make things happen. Therefore, half of the nitrogen in urea is actually derived from aspartate, not ammonia. Where does this aspartate come from?



12.3 Draw the urea cycle.

12.3.3 The urea cycle in context

Notes: To answer this question, we just need to pull together our previous knowledge about transamination as well as the citric acid cycle. Fumarate is turned into malate and then oxaloacetate in the citric acid cycle, so we can just borrow those reactions. Oxaloacetate can be transaminated by aspartate aminotransferase us-

ing glutamate (slide 6.9.2), which in turn acquired its nitrogen by transamination of some other amino acid destined for degradation. In other words, the aspartate simply serves as an intermediate carrier of nitrogen en route from amino acid degradation to urea synthesis.

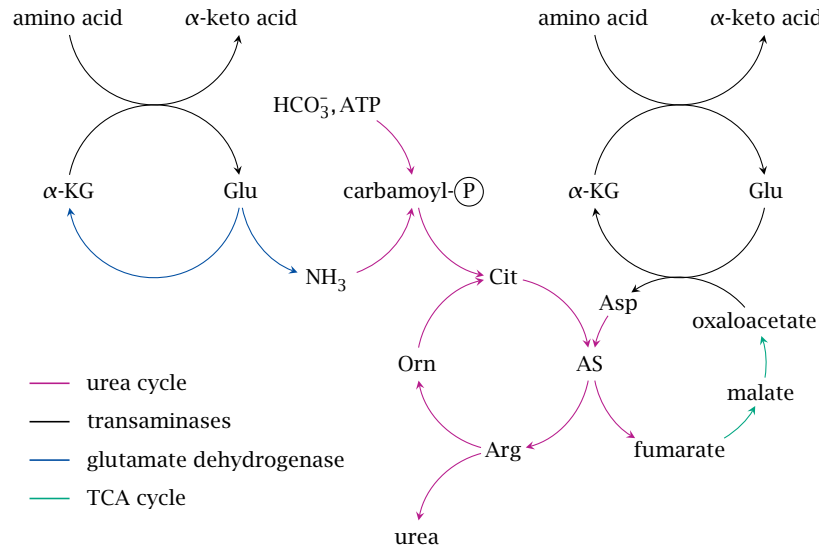

The network of reactions shown in this slide accounts for the disposal of nitrogen that accrues in amino acid degradation in the liver. As stated at the outset, other tissues also break down amino acids; for example, skeletal muscle metabolizes the lion's share of the branched-chain amino acids. Therefore, a mechanism is needed to ferry the nitrogen produced in the peripheral organs to the liver. Ammonia cannot be used as a carrier, since it is too toxic; amino acids are a better alternative. The two most important nitrogen carriers are alanine and glutamine (see below).

12.3.4 The urea cycle spans mitochondria and cytosol

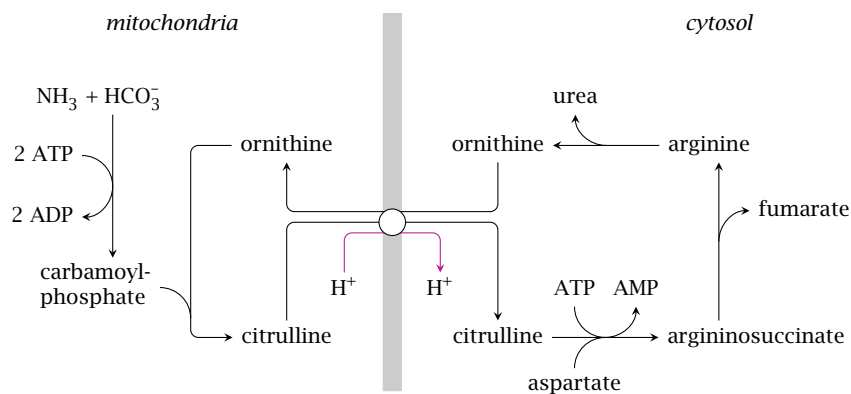

Notes: The carbamoylphosphate synthetase reaction and the ornithine transcarbamylase reaction occur inside the mitochondria, while the remaining reactions take place in the cytosol. This requires the transport of ornithine and citrulline, which

are exchanged for each other by a specific transporter in the inner mitochondrial membrane.

Ornithine has two free amino groups, while citrulline has one. The exchange transport is rendered electrically neutral by the cotransport of a proton out of the mitochondria, that is, against its concentration gradient. The energetic cost of this uphill transport is offset by the expenditure of ATP in other steps of the urea cycle. Nevertheless, the coupling of this substrate exchange to proton export will keep the cytosolic concentration of citrulline low at equilibrium.

Also note that the reactions that involve fumarate and aspartate occur in the cytosol. We had just noted that the conversion of fumarate back to aspartate involves some reactions borrowed from the TCA cycle. That cycle runs in the mitochondria; however, fumarate does not need to enter the mitochondria at this stage, since all required enzyme activities are also present in the cytosol.

12.3.5 The glucose-alanine cycle

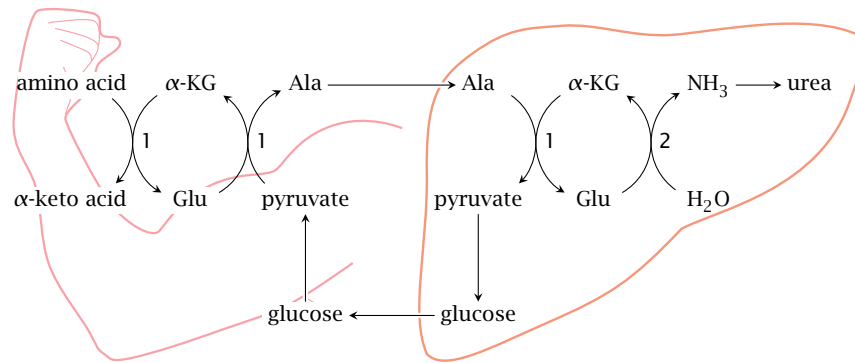

Notes: The glucose-alanine cycle is an interorgan cycle that piggybacks on the Cori cycle and accomplishes a net transport of nitrogen from muscle and other peripheral tissues to the liver. Here, pyruvate that is produced from glucose in the periphery is not reduced to lactate—as is the case in the Cori cycle, see slide 8.5.3—but instead transaminated to alanine, which is then transported to the liver. There, transamination is reversed, and pyruvate is converted again to glucose by gluconeogenesis. Release of glucose into the bloodstream and renewed glycolysis in the periphery close the cycle.

Apart from the reactions of glycolysis and gluconeogenesis, the cycle involves various transaminases (1) and glutamate dehydrogenase (2).

12.3.6 Nitrogen transport by glutamine

Notes: Glutamine is the most abundant amino acid in the blood; it is significant both as a nitrogen and a carbon carrier.⁶ It can bring about a net transfer of nitrogen from peripheral tissues to the liver in exchange for glutamate. The enzymes

⁶Some cell types, including leukocytes and the intestinal epithelia, use glutamine rather than glucose as their major energy-providing substrate.

involved in the overall scheme are transaminases (1), glutamate dehydrogenase (2), glutamine synthetase (3), and glutaminase (4). The latter two reactions are shown in detail in slide 12.3.7.

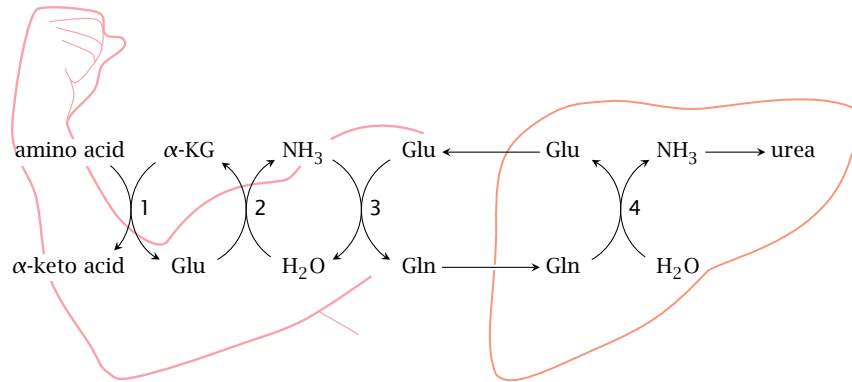

One might reason that, in the liver, glutamate could be further deaminated by glutamate dehydrogenase, and α -ketoglutarate be returned to the periphery, which would allow the transfer of two nitrogen atoms in each turn of the cycle. This should work in principle, but the plasma concentration of α -ketoglutarate is too low for it to be quantitatively important.



12.4 Explain how nitrogen that accrues in the degradation of amino acids in muscle tissue is transported to the liver.

12.3.7 The central role of glutamate in nitrogen disposal

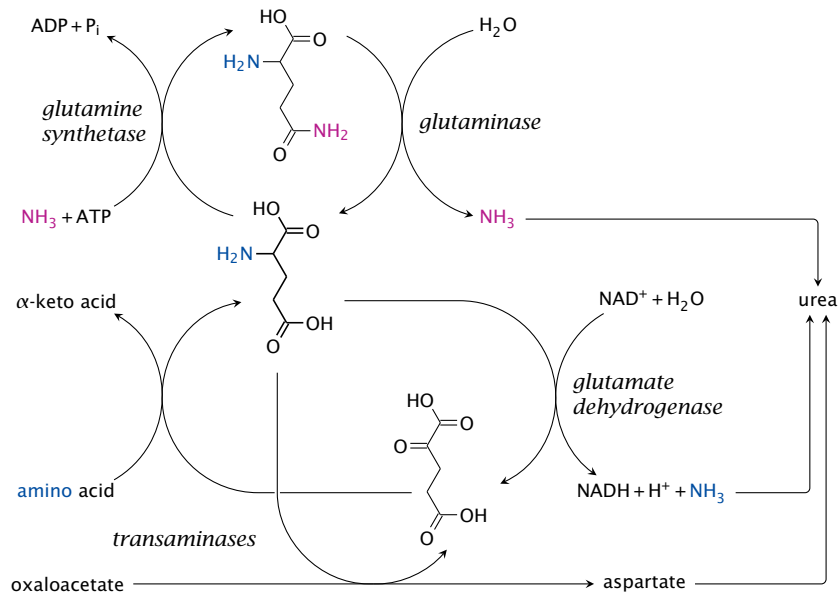

Notes: If we summarize the network of reactions in nitrogen elimination, we find that glutamate has a central place in it. Glutamate collects nitrogen from other amino acids through transamination and either releases it as ammonia or transfers

it to aspartate in order to feed the urea cycle. Together with glutamine, it also controls the level of free ammonia and accomplishes the transport of nitrogen between organs.

As shown in this scheme, glutamate is formed from glutamine by glutaminase, and it can be turned back into glutamine by glutamine synthetase.⁷ Evidently, both enzymes together would create a futile cycle that would accomplish nothing except ATP hydrolysis. In most organs, only one or the other enzyme has significant activity; for example, glutamine synthetase predominates in skeletal muscle (see slide 12.3.6), whereas glutaminase is abundant in the kidneys, which use it to secrete ammonium chloride into the urine when eliminating excess acid.

The liver contains both glutaminase and glutamine synthetase, which would suggest that futile cycling should occur. However, as it turns out, the enzymes are present inside the same tissue but not the same cells. Instead, they are distributed strategically within the liver lobule so as to create a confined compartment to host the urea cycle (see next slide).

12.3.8 Control of ammonia levels in the liver lobule

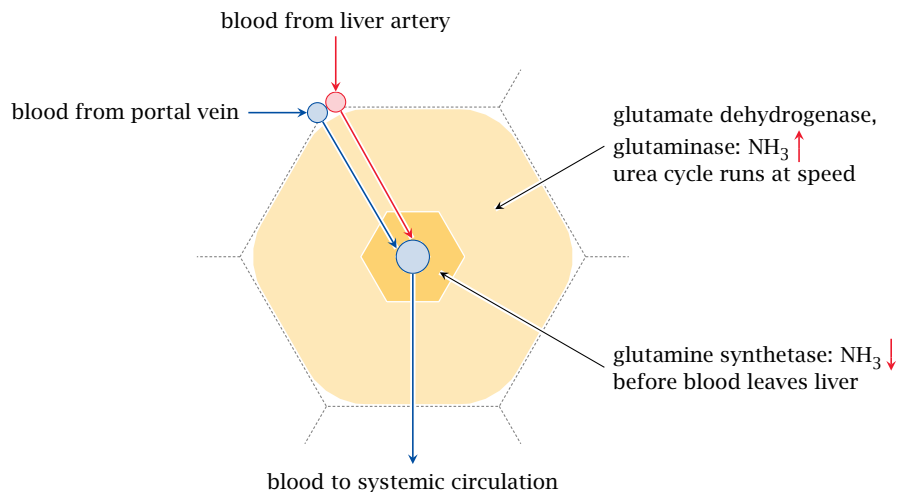

Notes: The toxicity of ammonia mandates that its concentration be kept very low in the systemic circulation. On the other hand, for the urea cycle to run at speed, the concentration must be high enough to saturate the initial enzyme, carbamoylphosphate synthetase, to a useful degree. Therefore, ammonia must be released when the blood enters the liver tissue, and scooped up again before the blood is drained away into the general circulation.

To make this work, the enzymes that release or fix ammonia, respectively, are strategically distributed in the liver tissue. We had seen before that the liver consists of functional units called lobules, with the blood filtering through each lobule from the periphery towards the center, from where it is drained toward the systemic circulation (slide 1.6.3). Glutaminase and glutamate dehydrogenase, which release ammonia, are found predominantly in the periphery of the lobule,

⁷The reaction mechanism of glutamine synthetase is shown in slide 2.4.1.

the so-called *periportal* zone. Here, they increase the concentration of free ammonia, allowing the urea cycle to run at speed. As the blood seeps into the *pericentral* zone toward the lobule's central vein, ammonia is scavenged again by glutamine synthetase before the blood is drained from the liver into the general circulation.

A similar spatial separation applies to the enzymes of arginine degradation. The first step in this pathway is catalyzed by arginase, which also functions in the urea cycle and produces ornithine. In the periportal zone, it would be deleterious to continue the degradation beyond ornithine, since this would drain the urea cycle of its intermediates. Therefore, the next enzyme in the pathway, ornithine aminotransferase, is only found in the periportal zone, in which the urea cycle must shut down anyway.

The purposeful distribution of different enzyme activities illustrates nicely how biochemical and anatomical levels of organization are interrelated, and how our body is not just a bag of cells, not even at the level of individual organs and tissues.

12.3.9 Regulation of the urea cycle

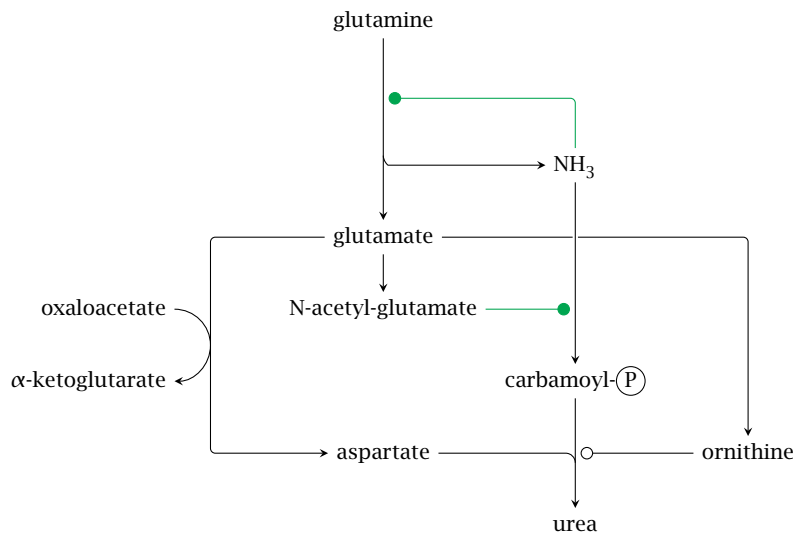

Notes: At the heart of the mechanisms that control flow through the urea cycle, we once again find glutamine and glutamate. Glutaminase gets the ball rolling by releasing ammonia from glutamine. Quite unusually, ammonia exercises positive feedback on glutaminase, which causes a rapid accumulation of both glutamate and ammonia. High levels of glutamate then promote the incorporation of ammonia into urea in several ways.

1. Some glutamate is converted to N-acetylglutamate. This is a regulatory molecule that allosterically activates carbamoylphosphatase.
2. Glutamate is also the biosynthetic precursor of ornithine. A high level of glutamate will also raise the level of ornithine, which will increase the flow through the urea cycle.

3. As we have seen, glutamate itself feeds nitrogen into urea synthesis via glutamate dehydrogenase or via aspartate.

Note that all these regulatory events amplify the flow through the urea cycle; they are the ones that run in the periportal zone of the liver lobule. As stated above, the urea cycle is shut down in the pericentral zone through the capture of remaining ammonia by glutamine synthetase as well as by ornithine degradation.



12.5 Explain how flow through the urea cycle is controlled within the liver lobule.

12.3.10 Hereditary enzyme defects in the urea cycle

- may affect any of the enzymes in the cycle
- urea cannot be synthesized, nitrogen disposal is disrupted
- ammonia accumulates, as do other metabolites depending on the deficient enzyme
- treatment
 - protein-limited diet
 - arginine substitution
 - alternate pathway therapy

Notes: Urea cycle defects primarily become symptomatic due to the accumulation of ammonia, which impairs brain function. Another aspect is the deficiency of arginine. In healthy individuals, arginine can be diverted from the urea cycle toward protein synthesis as required, but this supply is lacking if the cycle is disrupted. This may induce protein catabolism, thereby exacerbating the symptoms. The problem is addressed by the addition of arginine to the diet. If the enzyme defect is *not* between citrulline and arginine, it is possible to supply citrulline instead; this has the advantage of picking up one nitrogen equivalent en route to arginine.

The rationale for treating these enzyme defects with a protein-restricted diet is fairly obvious. Another, more intriguing approach is known as alternate pathway therapy. Here, the patients are given several innocuous organic acids that are substrates for conjugation with amino acids. These conjugates then serve as an alternative vehicle for the renal elimination of surplus nitrogen. This ingenious form of treatment is further discussed in slide [18.3.7](#).



12.6 Explain the pathogenesis and treatment of urea cycle enzyme defects.

12.4 Degradative pathways of individual amino acids

The degradation pathways for the individual amino acids vary considerably in complexity. As we had seen, some amino acids only require a single transamination step; on the other hand, others have lengthy degradation pathways with intriguing catalytic mechanisms. We will here consider some selected examples; several others are discussed in a later chapter (slides [15.2.4-15.2.7](#)).

12.4.1 Asparagine degradation

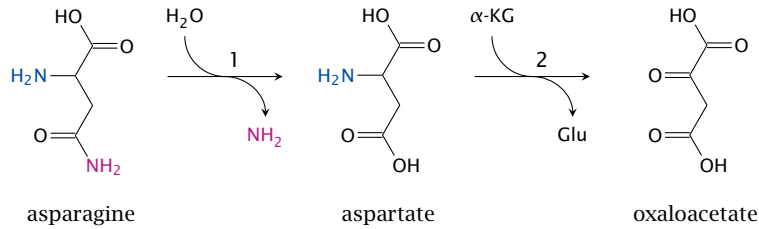

Notes: Asparagine is homologous to glutamine, and its degradation is analogous, too—just like glutaminase produces glutamate, asparaginase (1) produces aspartate, which can then be transaminated by aspartate aminotransferase (2) to oxaloacetate. Asparaginase is mentioned here not for any notable chemistry, but rather because of some interesting medical context.

Asparagine is a non-essential amino acid, which means that it can be synthesized by human cells; the enzyme responsible for this, asparagine synthetase, uses glutamine as the amide group donor. Nevertheless, in some forms of leukemia, the leukemic cells lack the synthetic capacity for asparagine. This can be exploited for therapy—the leukemia patients are treated with intravenous application of asparaginase.⁸ This lowers the serum level of asparagine and therefore starves the leukemic cells.



12.7 Explain the use of asparaginase in leukemia.

12.4.2 Serine dehydratase

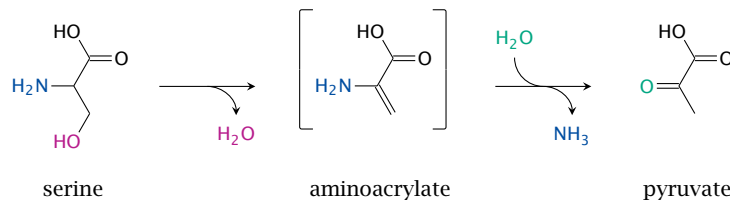

Notes: Serine, another non-essential amino acid, can be degraded along several different pathways; this slide shows one of them. Only the first step is enzymatically catalyzed; the aminoacrylate produced is unstable and spontaneously hydrolyzes to pyruvate. The second step releases ammonia, which must be disposed of. It seems that in humans the reaction occurs only in the liver, where the ammonia can directly enter the urea cycle.

Like the transaminases, the enzyme uses pyridoxal phosphate, and the role of the coenzyme is often presented along the lines of the usual electron sink

⁸The enzyme used for this treatment is purified from *E. coli*. In healthy patients, repeated injections of a bacterial protein would soon induce antibodies, which would quickly render the enzyme inactive. However, in leukemia patients, the disease itself, and the cytotoxic drugs simultaneously applied—such as, for example, cytosine arabinoside (slide 16.9.7)—conspire to suppress antibody formation. If it occurs anyway, enzyme prepared from another bacterium, *Erwinia chrysanthemi*, can be used. Immunogenicity of the enzyme can be reduced by derivatization of the protein with polyethyleneglycol (PEG).

mechanism (see slide 12.2.1). However, based on the crystal structure of the enzyme, a different mechanism has been proposed, in which no electron sink appears and instead the phosphate group of PLP plays a prominent role [72]. I am not enough of a chemist to judge how plausible this mechanism may be.

12.4.3 Serine-pyruvate transaminase

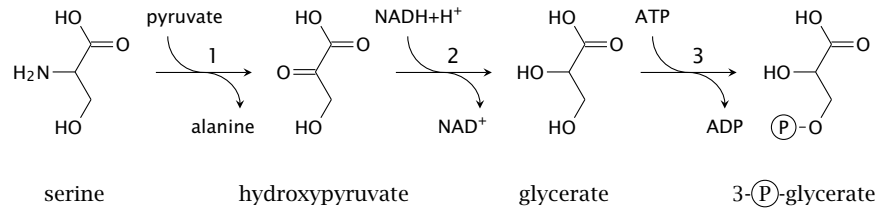

Notes: An alternative pathway starts with the transamination of serine rather than with deamination. In a departure from the usual routine, the transaminase employs pyruvate rather than α -ketoglutarate as its other substrate, which yields alanine (1); subsequently, of course, the nitrogen may yet be transferred from alanine to α -ketoglutarate. Serine itself is converted to hydroxypyruvate, which is then reduced to glycerate by hydroxypyruvate reductase (2). Glycerate kinase (3) produces 3-phosphoglycerate.

While both pyruvate, which is produced by serine dehydratase, and the 3-phosphoglycerate produced here can serve as substrates for gluconeogenesis, the transamination pathway shown in this slide avoids the release of free ammonia. It would therefore be preferable in tissues other than the liver.

A third alternative for serine degradation is provided by serine hydroxymethyltransferase, which produces *N,N*-methylene tetrahydrofolate and glycine. This pathway is covered in slide 15.2.4.



12.8 Summarize the three pathways for serine degradation.

12.4.4 Degradation of leucine

Notes: Leucine, isoleucine and valine are collectively referred to as the branched-chain amino acids. Unlike the other amino acids, these ones undergo degradation mostly in skeletal muscle. This is reminiscent of fatty acids, which are also degraded prominently in muscle, and indeed several steps in leucine degradation have similarity with the reactions we have seen in fatty acid metabolism. Leucine degradation involves the following steps:

1. Transamination by branched chain amino acid (BCAA) transaminase yields α -ketoisocaproate.
2. α -Ketoisocaproate is decarboxylated and dehydrogenated by branched chain α -keto acid dehydrogenase. Like the transaminase in step 1, this dehydrogenase participates in the degradation of all branched chain amino acids (valine, leucine, isoleucine). The reaction mechanisms and the structural organization

of this enzyme are completely analogous to pyruvate dehydrogenase and α -ketoglutarate dehydrogenase, and all use the very same E_3 subunit (see slide 5.4.4).

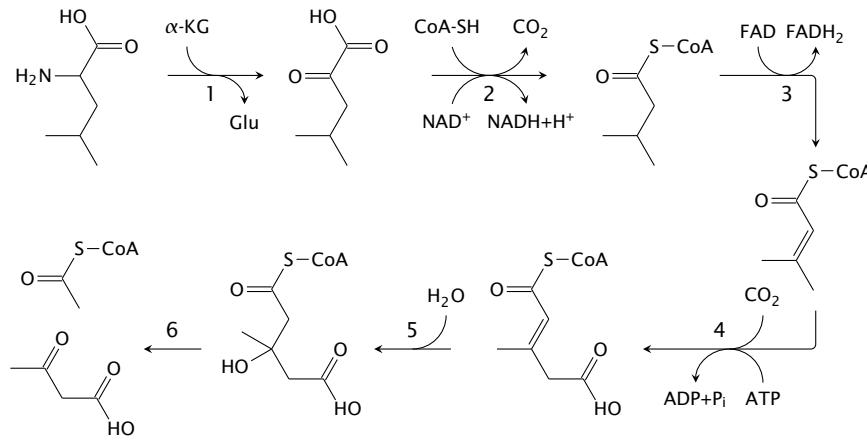

- The resulting metabolite, isovaleryl-CoA, is similar in structure to a fatty acyl-CoA. It likewise undergoes a FAD-dependent dehydrogenation reaction (by isovaleryl-CoA dehydrogenase), which yields isopentenyl-CoA.
- Biotin-dependent carboxylation yields methylglutaconyl-CoA. In all of the previous carboxylation reactions we have seen, carboxylation was facilitated by a vicinal carbonyl group, which tends to withdraw electrons from the carbon being carboxylated. This electron-withdrawing effect can be relayed by a conjugated C=C double bond, which is the case here.⁹
- Addition of water by methylglutaconyl-CoA hydratase yields HMG-CoA.
- HMG-CoA is split by HMG-CoA lyase to acetyl-CoA and acetoacetate.

The final reaction occurs in the very same way in ketone body synthesis (see slide 10.4.1). Evidently, therefore, leucine is a purely ketogenic amino acid.



12.9 Describe the degradation pathway of leucine.

12.4.5 Degradation of phenylalanine and tyrosine

Notes: While the degradation of leucine shows a comforting similarity to previously encountered pathways, the situation is profoundly different with phenylalanine. This is due to the aromatic nature of the side chain. Aromatic rings are quite stable, and therefore some brute force is needed to crack them open. The best tool for this task is molecular oxygen, and a liberal dose of it is used in the breakdown of phenylalanine. The pathway involves the following reactions:

- Phenylalanine is converted to tyrosine by phenylalanine hydroxylase. In this reaction, the second oxygen atom is released as water, reduced at the expense of the redox cosubstrate tetrahydrobiopterin (BH_4).

⁹The mediation of electron-withdrawing effects by conjugated C=C double bonds is referred to as the *vinyllogous* effect.

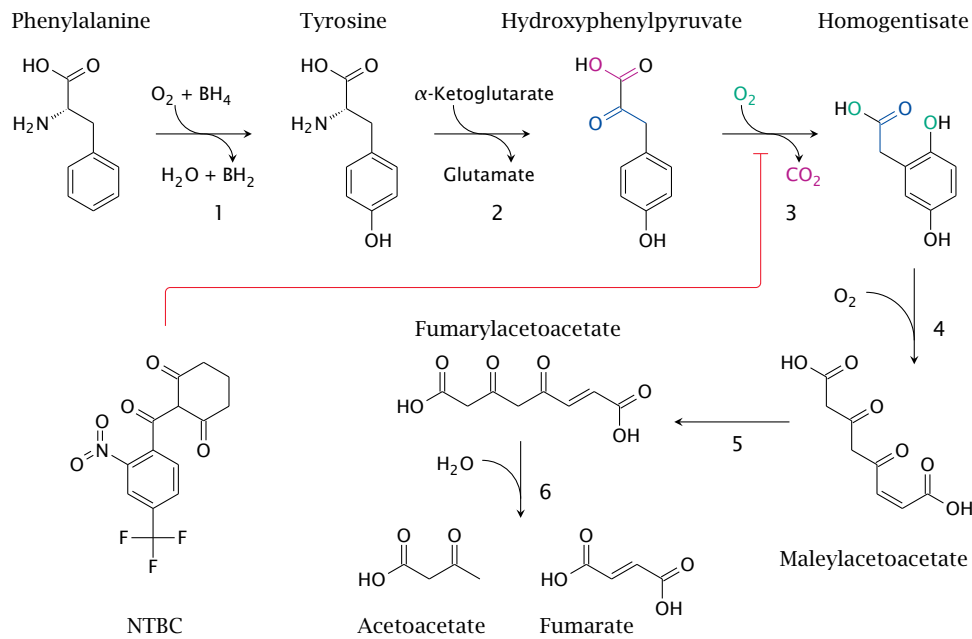

2. Tyrosine transaminase yields *p*-hydroxyphenylpyruvate.
3. *p*-Hydroxyphenylpyruvate dioxygenase uses another oxygen molecule to turn hydroxyphenylpyruvate into homogentisate. I have traced the bits and pieces in this reaction using colors, but an actual explanation of the advanced magic performed by the enzyme is beyond my feeble powers of narration.
4. Ring cleavage by homogentisate dioxygenase uses a third molecule of oxygen. The product is maleylacetoacetate.
5. Maleylacetoacetate isomerase produces fumarylacetoacetate.
6. Fumarylacetoacetate hydrolase releases fumarate and acetoacetate.

Since the first transformation of phenylalanine yields tyrosine, it follows that the pathway accounts for the degradation of both amino acids, and moreover that tyrosine is not an essential amino acid. Of the two final products, fumarate can enter gluconeogenesis, while acetoacetate cannot.

2-[2-Nitro-4-(trifluoromethyl)benzoyl]cyclohexane-1,3-dione¹⁰ (NTBC), also shown in this slide, is an inhibitor of *p*-hydroxyphenylpyruvate dioxygenase. The use of this inhibitor in tyrosinemia will be explained below.

12.5 Hereditary enzyme defects in amino acid metabolism

Since there are so many different pathways for the degradation of the various amino acids, it is understandable that many of the known inborn errors of metabolism are related to amino acid metabolism. We will consider a few examples that affect the pathways discussed here.

¹⁰As you may have guessed, that full name was a straight copy-and-paste job.

12.5.1 Phenylketonuria (PKU)

- homozygous defect of phenylalanine hydroxylase
- affects one in 10,000 newborns among Caucasians; frequency differs with race
- excess of phenylalanine causes symptoms only after birth; intrauterine development normal
- cognitive and neurological deficits, probably due to cerebral serotonin deficit
- treatment with phenylalanine-restricted diet
- some cases are due to reduced affinity of enzyme for cofactor THB, can be treated with high dosages of THB

Notes: As with most genetic enzyme defects, the clinical disease is manifest only in homozygous individuals. Dietary phenylalanine that is not used for protein synthesis accumulates and causes toxicity. It appears that the excess phenylalanine crowds out tryptophan at the L-aromatic amino acid transporter in brain capillaries. This transporter keeps the brain supplied with all aromatic amino acids. Since tryptophan is the precursor of the neurotransmitter serotonin, the competitive inhibition of its transport to the brain results in a lack of cerebral serotonin [73], which is believed to cause the observed deficits in brain function and development.

In addition to phenylalanine itself, some aberrant metabolites derived from it also occur at increased levels, and the appearance of ketone derivatives such as phenylpyruvic acid in the urine has given the disease its name. These metabolites have no proven connection to the pathogenesis of the disease.

12.5.2 The Guthrie test for diagnosing phenylketonuria

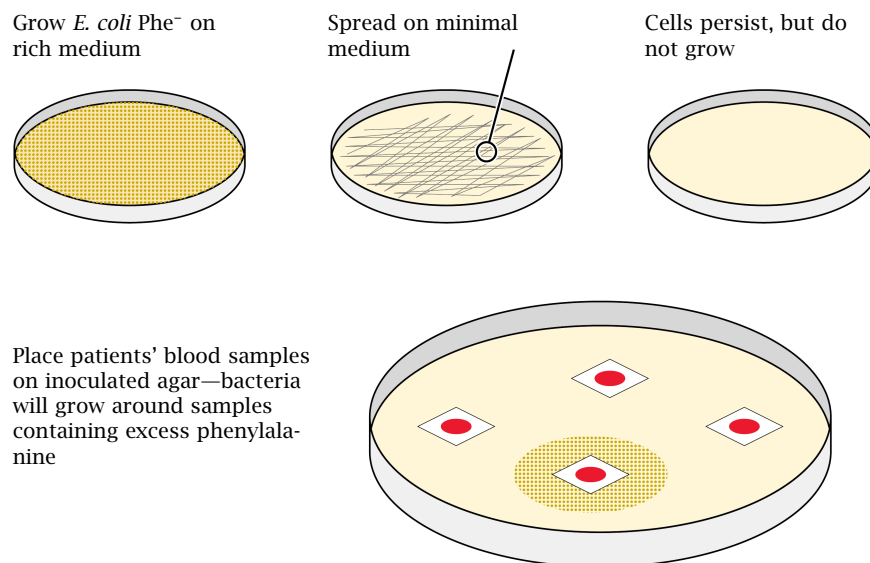

Notes: The treatment of phenylketonuria is pretty straightforward: Limitation of dietary phenylalanine. Tyrosine is sufficiently available in a reasonably protein-rich diet, so that the lack of its endogenous formation won't be a problem. The

challenge, then, is to diagnose the disease in newborn kids, before any damage is done. Happily, the enzyme defect does not cause a problem during fetal development, since the placenta constantly equilibrates both useful and potentially harmful metabolites between the maternal and the fetal circulation. Buildup of a metabolite in the fetus will therefore not occur as long as the mother's metabolism is able to degrade it.

The modern test for phenylketonuria is effective but boring—a sample of blood is drawn, and the phenylalanine concentration in the serum is determined by HPLC. The original test—the Guthrie test—was a bit more roundabout in principle, yet ingenious and exceedingly simple and cheap in practice. Moreover, it well illustrates the power of bacterial genetics in biochemistry, and it therefore merits discussion here.

In contrast to mammalian cells, the bacterium *Escherichia coli* can synthesize all 20 standard amino acids, as long as it has ammonia, some inorganic salts, and an organic carbon source such as glucose. Such a substrate mixture constitutes a *minimal medium*. The Guthrie test makes use of a mutant *E. coli* strain that is Phe⁻, which means that it is unable to synthesize phenylalanine on its own. This strain can be grown on a rich medium that supplies phenylalanine; however, when spread onto minimal medium, it will not grow.

Now, if we take a little snippet of filter paper soaked with a drop of baby blood and place it on top of the inoculated minimal medium, any phenylalanine contained in it will diffuse into the surrounding agar. If there is enough of it in the sample, this will allow the bacteria in the vicinity to resume growth. Therefore, a zone of bacterial growth surrounding a blood sample will identify a patient with phenylketonuria. Brilliant!

Note that, for this test to work, we cannot collect the blood sample right away after birth. As noted above, the fetal blood equilibrates with the mother's, and so the phenylalanine concentration is only slightly increased at birth. We therefore must allow 1-2 weeks after delivery for phenylalanine to accumulate in the child's blood for the Guthrie test to respond. This is a drawback of the test relative to the HPLC method—the latter is more quantitatively accurate and readily detects the smaller increase in phenylalanine concentration that is present at the time of delivery.

12.5.3 Ochratoxin A inhibits phenylalanyl-tRNA synthetase

Notes: The variation of the gene frequency for PKU between races and geographical areas suggests that some regional environmental conditions may confer a selective advantage to the heterozygous state, as is the case with sickle cell anemia and glucose-6-phosphate dehydrogenase deficiency in regions with endemic malaria. It has been proposed that the heterozygote advantage in PKU consists in protection from the fungal toxin ochratoxin A, which is produced by some *Aspergillus* molds that cause food to rot [74].

Ochratoxin A competitively inhibits the coupling of phenylalanine to its cognate tRNA by the corresponding aminoacyl transferase and thereby disrupts pro-

tein synthesis. It is more toxic to fetuses than to adults, most likely because fetuses are short of the enzymes that inactivate xenobiotics and toxins such as ochratoxin. Mothers who are heterozygous for PKU will have a somewhat higher level of phenylalanine, which will be shared with the fetus via the placenta. This will counter the inhibition of tRNA aminoacylation in the fetus and thereby afford it some measure of protection.

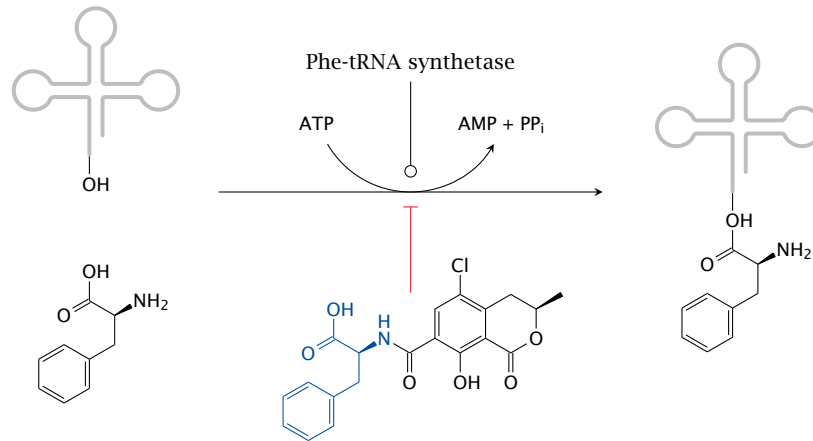

One of the places with the highest abundance of PKU is Ireland. This country is also known for its repeated historic episodes of severe famine. Starving people will tend to eat rotten food rather than discard it. Indeed, reference [74] reports that lowered rates of abortion were found in Irish women who were heterozygous for PKU. I have not ascertained whether the time periods covered by those statistics coincided with periods of actual famine.



12.10 Explain the cause, pathogenesis, diagnosis and treatment of phenylketonuria.

12.5.4 Tyrosinemia

- homozygous defect of fumarylacetoacetate hydrolase
- fumarylacetoacetate and preceding metabolites back up
- fumaryl- and maleylacetoacetate react with glutathione and other nucleophiles, causing liver toxicity
- the drug NTCB inhibits *p*-hydroxyphenylpyruvate dioxygenase, intercepting the degradative pathway upstream of the toxic metabolites
- dietary restriction of tyrosine required to prevent neurological deficit

Notes: Tyrosinemia is comparatively common in Quebec. In this case, there seems to be no heterozygote advantage; instead, the high incidence is due to the so-called *founder effect*, that is, the common descent of the afflicted population from a small group of founding settlers that happened to contain one or several carriers of the gene. (Refer to slide 12.4.5 for the relevant pathway and enzyme reactions.)



12.11 Explain the cause, pathogenesis, diagnosis and treatment of tyrosinemia.

12.6 Answers to practice questions

12.1: We need dietary protein because we lack the biosynthetic pathways for about half of all amino acids, which we nevertheless require for our own protein synthesis.

Glucogenic amino acids are those that can be converted to substrates of gluconeogenesis. Ketogenic amino acids are those that yield acetoacetate and/or acetyl-CoA. Lysine and tryptophan are strictly ketogenic, phenylalanine and tyrosine match both categories, and all others are glucogenic.

12.2: In amino acid transamination, the substrate becomes covalently bound to PLP via an aldimine bond, through which the coenzyme reversibly abstracts electrons from the substrate. In contrast, glycogen phosphorylase uses the phosphate group of PLP to transiently deprotonate a substrate phosphate ion.

12.3: See schemes in slides 12.3.1 and 12.3.2.

12.4: The nitrogen is transported to the liver in the form of alanine and glutamine. Alanine is formed through transamination of pyruvate, whereas glutamine is formed from glutamate by glutamine synthetase. The liver retrieves the nitrogen again via transamination (alanine) and through glutaminase.

12.5: The urea cycle is activated in the periportal zone of the lobule by glutaminase and glutamate dehydrogenase, which release free ammonia from their substrates. Glutamate also gives rise to ornithine, which increase the pool of urea cycle intermediates, and to N-acetylglutamate, which allosterically activates carbamoylphosphate synthetase. In the pericentral zone of the lobule, the cycle is shut down by ornithine degradation and by glutamine synthetase, which captures remaining free ammonia.

12.6: Enzyme defects in the urea cycle disrupt the disposal of nitrogen and lead to the accumulation of ammonia, which is neurotoxic. Since the urea cycle also serves to supply arginine, that amino acid is often lacking and must be substituted. Additionally, these conditions are treated with a protein-restricted diet. Finally, alternate pathway therapy uses organic acids that undergo amino acid conjugation; the conjugates are excreted and thus cause the removal of surplus nitrogen from the body.

12.7: Some types of leukemic cells lack the capacity to synthesize asparagine and are therefore susceptible to its depletion in the blood by asparaginase. Normal cells are not affected by this treatment.

12.8: 1) Serine dehydratase induces deamination of serine to pyruvate, 2) serine-pyruvate transaminase produces glycerate, and 3) serine hydroxymethyltransferase produces glycine and *N,N*-methylene tetrahydrofolate.

12.9: The degradation pathway begins with transamination and a subsequent step that resembles pyruvate dehydrogenase. The resulting acyl-CoA undergoes FAD-dependent β -dehydrogenation, carboxylation and hydration; this produces HMG-CoA, which in turn yields acetoacetate and acetyl-CoA.

12.10: PKU is due to a homozygous enzyme defect for phenylalanine hydroxylase. Phenylalanine builds up and dislodges tryptophan from the shared transporter that mediates uptake of both amino acids into the brain, which causes a lack of tryptophan and hence serotonin in the brain. The disease can be diagnosed by direct measurement of phenylalanine plasma levels or through the Guthrie test, which is a phenylalanine-auxotrophic bacterial strain. Treatment consists in a phenylalanine-restricted diet.

12.11: Tyrosinemia is due to a homozygous defect of fumarylacetoacetate hydrolase. This causes the build-up of fumarylacetoacetate and maleylacetoacetate, which are chemically reactive and cytotoxic. Treatment uses dietary restriction and NTCB, which inhibits *p*-hydroxyphenylpyruvate dioxygenase and thereby forestalls the build-up of the toxic metabolites downstream.

Chapter 13

Hormonal regulation of metabolism

13.1 Hormones that affect energy metabolism

Hormone	Message
insulin	glucose and amino acids available, more substrates on the way
glucagon	glucose and amino acids in short supply, need to mobilize internal reserves
epinephrine	prepare for imminent sharp rise in substrate demand
glucocorticoids	prepare for extended period of high demand
thyroid hormones	increase basal metabolic rate

Notes: We have already touched briefly on the effects of insulin, glucagon and epinephrine on gluconeogenesis and glycogen metabolism. In this chapter, we will take a more thorough look at these hormones' properties and activities. This will provide the foundation for the next chapter, in which we will consider the disruptions of metabolic regulation that occur in diabetes mellitus.

Of the hormones listed in the table, only insulin has the effect of lowering blood glucose. The other hormones are all antagonistic to insulin, and a pathological increase in their secretion may result in symptomatic diabetes. In the case of glucocorticoids, symptomatic diabetes may also arise from their use as drugs.

Both glucocorticoids and thyroid hormones cause their effects mostly through up- and down-regulating gene transcription. The two types of hormones control different sets of target genes, but both upregulate the expression of β -adrenergic receptors, that is, receptors for epinephrine, and so amplify the metabolic effects of this hormone.



13.1 Which hormones are antagonistic to insulin with respect to the blood glucose level?

13.2 Insulin

13.2.1 Langerhans' islets in the pancreas produce insulin and glucagon

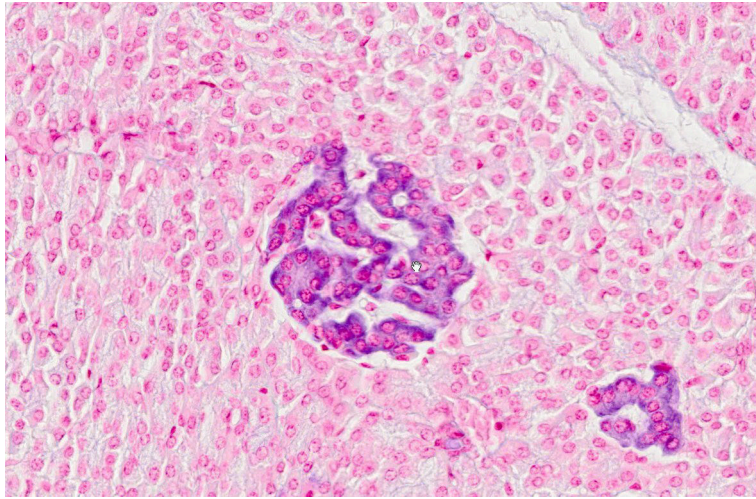

Notes: Insulin is produced in the islets of Langerhans, which are small clusters of cells that occur interspersed within the exocrine pancreas. In this picture, one islet is shown in the center, and a tangential section across another is seen in the bottom right. The two islets are embedded in a “red sea” of exocrine pancreas tissue.

The function of the exocrine pancreas—secretion of digestive enzymes and of bicarbonate into the small intestine—has been discussed in slide 1.6.7. The products of islet cells are secreted into the bloodstream; therefore, the islets collectively function as an endocrine gland. Among the several cell types found in the islets, the β -cells produce insulin, whereas the α -cells produce glucagon.

13.2.2 A little bit of history: The purification of insulin—the problem

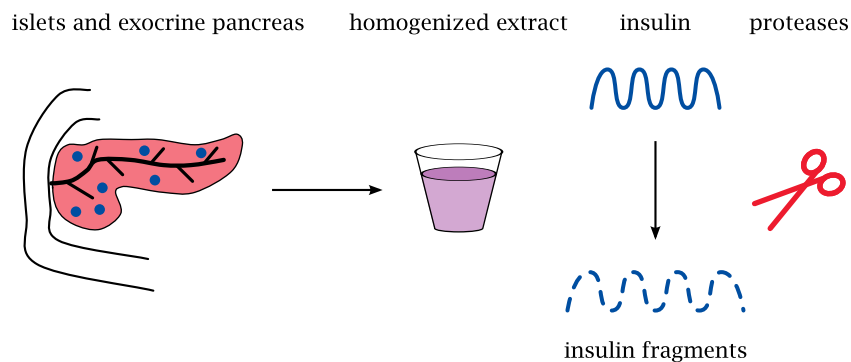

Notes: When purifying a protein of interest from some organ, standard practice is to first grind up the tissue with a homogenizer, and then to subject the homogenate to various fractionation procedures so as to incrementally enrich the protein,

until it is sufficiently clean. With pancreatic tissue, homogenization releases large amounts of proteases from the exocrine gland cells; these enzymes will then chop up any other protein contained in the homogenate before it can be purified. Once it had been recognized that pancreatic islets must contain an anti-diabetic hormone, the proteases present in the pancreas homogenates foiled initial attempts to purify it.¹

13.2.3 The purification of insulin—Banting's solution

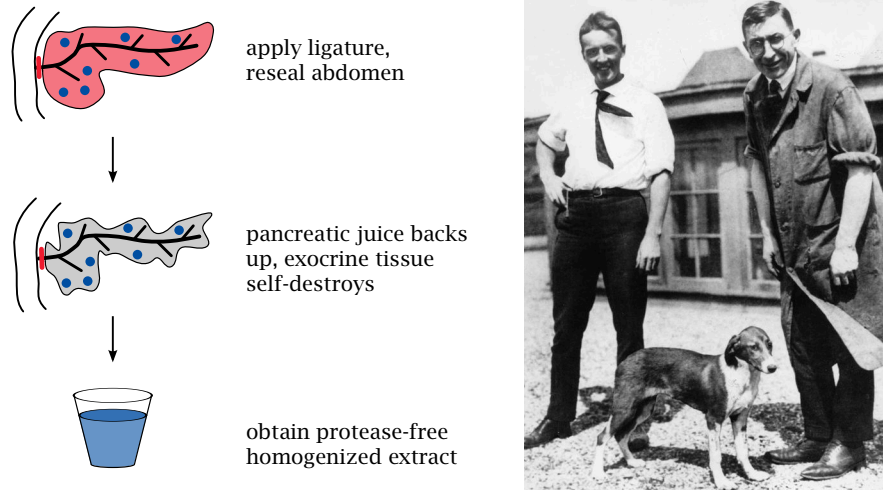

Notes: The bright idea that overcame this problem occurred, in one of his sleepless nights, to a young physician named Frederick Banting. He immediately resolved to pursue this idea at the University of Toronto, where he was joined in this effort by a junior colleague, Charles Best.

It had previously been observed in human patients that occlusion of the pancreatic duct induced a protracted self-destruction of the exocrine pancreas, while sparing the pancreatic islets. Banting surgically obstructed the pancreatic ducts of experimental animals to induce destruction of the exocrine pancreas. The source of the contaminating proteases was thus removed, and Banting and his colleagues were able to extract and purify insulin from the islets that remained intact within the biochemically inert scar tissue that had replaced the exocrine pancreas.

It is worth noting that Banting and his colleagues did *not* proceed to claim a patent, but instead shared their discovery freely, encouraging everyone else to use it. Their generosity ensured that the diabetics of the world were soon supplied with insulin.



13.2 How did Banting solve the problem of proteolytic degradation of insulin in pancreas extract?

¹In modern practice, one could likely prevent this using protease inhibitor cocktails; however, such inhibitors were not available at the time.

13.2.4 Historical side note: Norman Bethune, Banting's famous classmate



“Comrade Bethune’s spirit, his utter devotion to others without any thought of self, was shown in his great sense of responsibility in his work and his great warmheartedness towards all comrades and the people. Every Communist must learn from him.”

Mao Zedong, “In Memory of Norman Bethune”

Notes: Of historical interest, but not relevant to the main subject, is that one of Banting’s classmates at medical school was Norman Bethune, a gifted surgeon who invented many surgical instruments and introduced mobile blood transfusion units in the Spanish civil war. He later accompanied Mao Zedong and his guerrilla fighters on their Long March across China, a long and costly, but ultimately successful retreat from the advancing Kuomintang that occurred during the civil war of the 1930s.

The picture on the left shows Bethune performing surgery in a makeshift operation room during the Long March; during one such operation, Bethune contracted a bacterial infection to which he subsequently succumbed. The picture on the right shows Bethune’s birthplace in the city of Gravenhurst, which is located in Ontario’s Muskoka region. It is now a museum and is well worth a visit.

 **13.3** When was the Spanish Civil War?

13.2.5 Structure of insulin and its precursors (1)

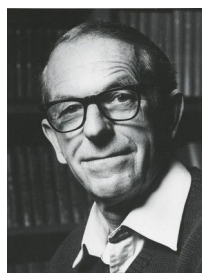

Notes: The insulin molecule consists of two peptide chains, which are held together by two disulfide bridges. The sequence of insulin was the very first protein sequence ever to be determined, and the methodology for this feat was developed by the gentleman with the sardonic smile, Frederick Sanger.

Sanger went on to develop similarly ingenious methods for sequencing RNA and DNA. His own account of these discoveries [75], appropriately entitled “Sequences, sequences and sequences,” is quite humorous and well worth reading.

13.2.6 Structure of insulin and its precursors (2)

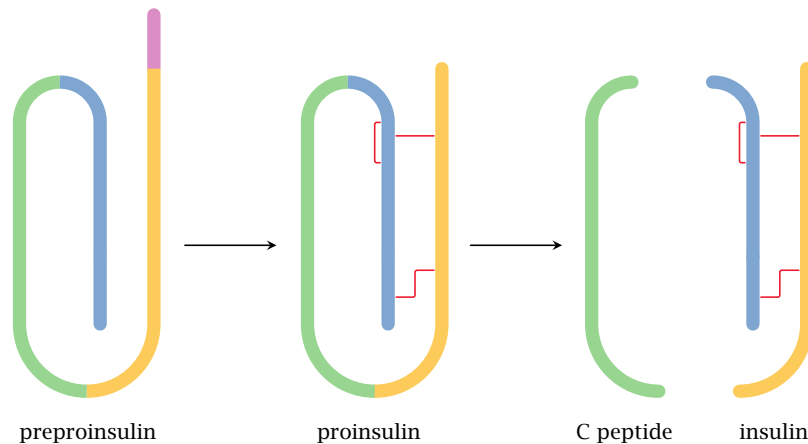

Notes: Pre-proinsulin is the primary translation product, as it runs off the ribosome at the membrane of the rough endoplasmic reticulum. It still contains the N-terminal signal peptide and lacks the disulfide bridges. The signal peptide is cleaved off, and the disulfide bonds are formed en route from the ER via the Golgi apparatus to the secretory vesicles. The C-peptide is cleaved off as well, but it remains inside the vesicles and is secreted together with insulin.

C-peptide has for a long time been considered physiologically irrelevant; it was used only as a diagnostic parameter to assess the residual secretory function of β -cells in type 2 diabetics. However, several recent experimental studies support the idea that C-peptide itself is active as a growth factor, and that its lack in type 1 diabetes contributes to the development of diabetic long-term complications. On cell surfaces, saturable binding sites have been characterized, suggesting the existence of a specific receptor; however, no receptor has yet been purified. In small-scale pilot studies on type 1 diabetics, beneficial effects have been observed when insulin was supplemented with C-peptide. However, these studies have not yet translated into routine therapy of diabetes [76].



13.4 What is the C-peptide, and what is its significance?

13.2.7 Sequences of human, swine, and bovine insulins

Notes: Until the late 1980s, swine and cow insulins were the mainstay of insulin substitution therapy. They are fully active in humans but differ from human insulin in one or three amino acid positions, respectively. This difference may promote the formation of antibodies, which bind and inactivate insulin. Recombinantly

expressed human insulin has replaced the animal insulins in therapy, which has largely done away with this problem.²

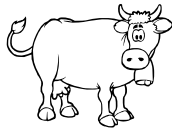
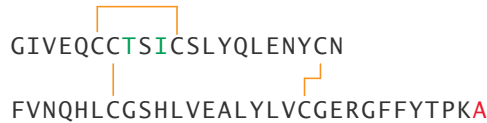

13.2.8 Insulin secretion in the β -cell is controlled by glucose and triggered by membrane depolarization

Notes: While insulin controls the rate of glucose uptake in many tissues, the β -cells, which control the release of insulin, themselves take up glucose in an insulin-independent manner; the rate of uptake cells thus simply depends on the plasma glucose level. Inside the β -cells, glucose undergoes degradation, which increases the cellular level of ATP. The ATP then binds to the sulfonylurea receptor, which in turn closes a potassium channel associated with it. This leads to an increase in the membrane potential, which activates a voltage-gated Ca^{++} channel. Ca^{++} entering the cell triggers the exocytosis of insulin and C-peptide.

Glucose is not the only substrate that can be degraded to yield ATP, and it is not surprising that some amino acids and fatty acids will also promote insulin secretion. In addition, several types of cell surface receptors contribute to the activation of insulin secretion in a manner that is not dependent on substrate degradation.

²More recently, recombinant insulins with point mutations have been introduced into clinical treatment. Interestingly, these insulins seem to be less prone to antibody induction than porcine and bovine insulins were. This may be due to their reduced tendency to form aggregates (see slide 14.5.11).

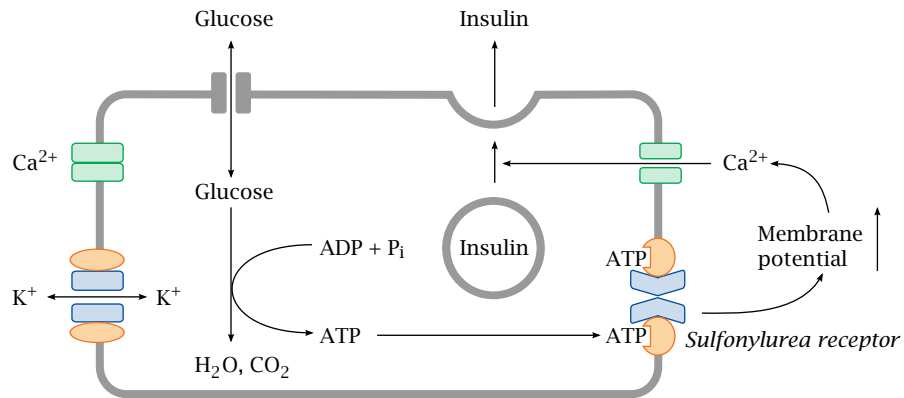

13.2.9 The sulfonylurea receptor controls an associated potassium channel

Notes: This figure illustrates how the polypeptide chains of the sulfonylurea receptor and of the associated “inward rectifier” K_{ir} channel crisscross the cell membrane. The N-terminus of the sulfonylurea receptor is extracellularly located. NBF1 and NBF2 are nucleotide-binding folds, that is, conserved protein sequence motifs that are involved in the binding of ATP.

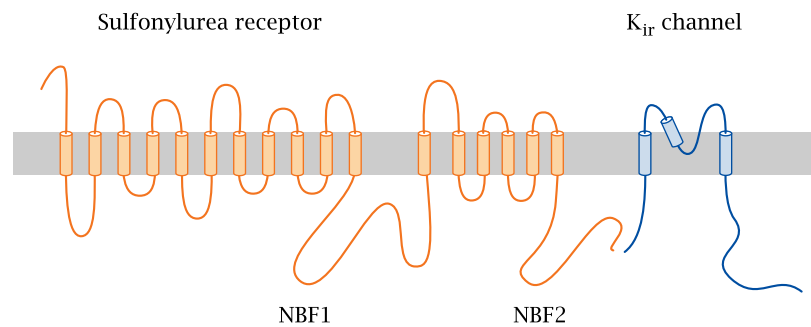

The scheme shows a single K_{ir} molecule; however, a functional K^+ channel consists of four K_{ir} subunits. The entire ensemble of K_{ir} and sulfonylurea receptor subunits is referred to as a K_{ATP} channel.

13.2.10 K_{ATP} channels also regulate the tone of smooth muscle cells

Notes: K_{ATP} channels serve in more than one physiological role. In vascular smooth muscle cells, K_{ATP} channels regulate the strength of contraction. Sustained contraction of a muscle cell will reduce its ATP level, which will promote dissociation of ATP from the sulfonylurea receptor and open the connected K_{ir} channel. The increase in K^+ permeability will lower the membrane potential and inhibit the activation of voltage-gated calcium channels; this, in turn, will inhibit cell contraction. This mechanism protects the cell from excessive exertion: when ATP is depleted, the opening of the K_{ATP} channels will cause the cell to ignore any

further calcium signals and suspend contraction until it has caught its breath and replenished ATP.

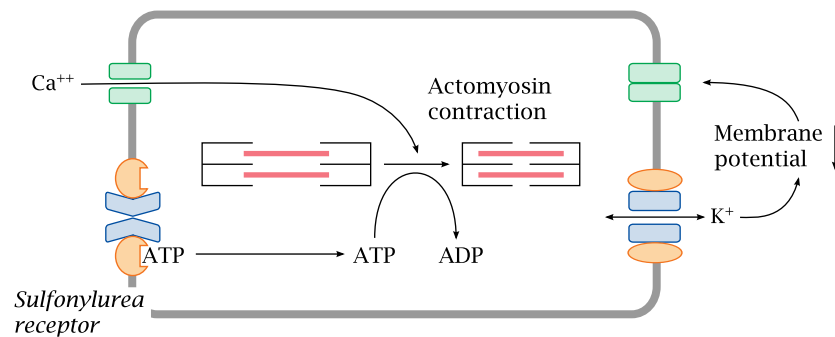

Drugs that counteract the effect of ATP on the sulfonyleurea receptor will keep the K_{ir} open and promote relaxation of vascular smooth muscle cells. This is an effective means to lower blood pressure.

13.2.11 Tolbutamide promotes closing of the K_{ATP} channel

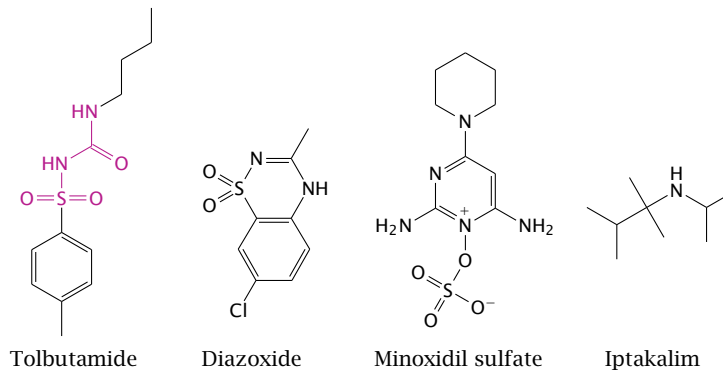

Notes: The sulfonyleurea receptor is so named because it responds to sulfonyleurea derivatives such as tolbutamide. The effect of tolbutamide augments that of ATP, so that a given level of glucose/ATP results in the secretion of more insulin. This is a useful therapeutic principle in type 2 diabetes, as long as the patients' β -cells remain functional. It is ineffective in type 1 diabetes, since the β -cells are destroyed in this condition (see chapter 14).

The drugs diazoxide and minoxidil contain structurally similar moieties but inhibit the sulfonyleurea receptor. They are used to induce vascular relaxation, but diazoxide in particular also reduces insulin secretion as a side effect. The drug iptakalim reportedly activates the vascular K_{ATP} channel but inhibits the one on β -cells; this would combine the two beneficial effects. Iptakalim likely interacts directly with the K_{ir} channel rather than with the sulfonyleurea receptor.



13.5 What is the mode of action and the therapeutic use of sulfonyleurea drugs (e.g. tolbutamide)?

13.2.12 The insulin receptor is a receptor tyrosine kinase

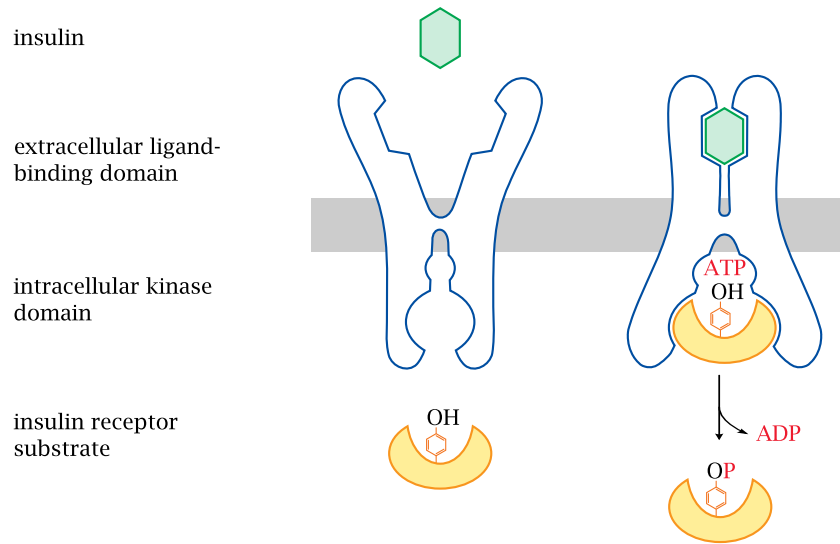

Notes: The insulin receptor is found on the surface of all body cells that respond to the hormone. The highest receptor density is found on liver cells; in fact, more than half of the insulin that is released by the pancreas is captured by receptors in the liver (recall that venous blood from the pancreas is drained into the portal vein; see slide 1.6.2).

The insulin receptor is located in the cytoplasmic membrane; it is a receptor tyrosine kinase. Aside from insulin, human growth hormone and many other growth factors have receptors of this type. Receptor tyrosine kinases are one of the major functional classes of hormone receptors.

A receptor tyrosine kinase has two functional domains. The extracellular domain binds to the hormone. This causes a conformational change to the entire receptor, which activates the intracellular protein tyrosine kinase domain. The activated receptor binds one or several cognate protein substrates, which it then phosphorylates at specific tyrosine residues. The phosphorylated substrates leave the receptor and interact with downstream adapter proteins, which then set off various intracellular signaling cascades.

13.2.13 Insulin receptor first phosphorylates itself and then a number of insulin receptor substrate proteins

Notes: In the case of insulin receptor, the first target for phosphorylation is another insulin receptor molecule; mutual phosphorylation of the two receptors locks both into the active conformation. Subsequently, the receptor molecules phosphorylate a series of regulatory proteins, which are referred to as *insulin receptor substrates* (IRS).



13.6 What is the signaling mechanism of the insulin receptor?

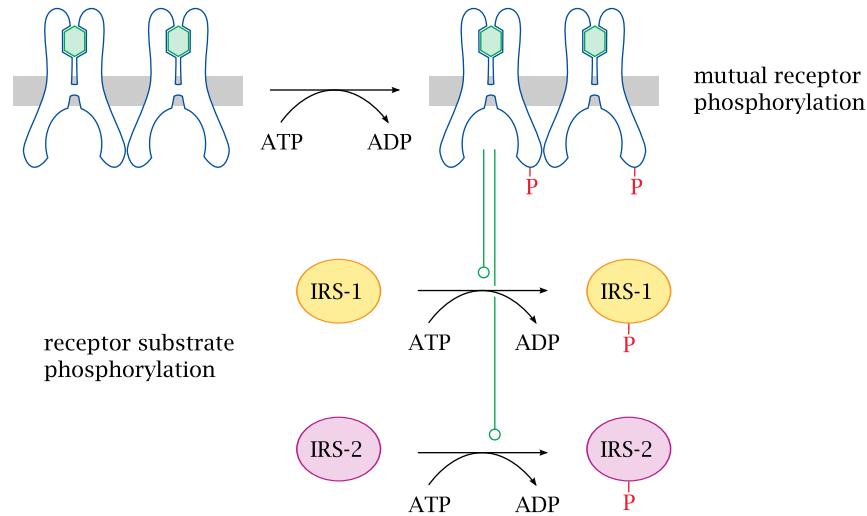

13.2.14 Insulin effects on glycogen synthesis

Notes: The effect of insulin on glycogen synthesis is mediated through a cascade that involves phosphorylated insulin receptor substrate 1 (IRS-1), phosphatidylinositol-3-kinase (PI-3K), and protein kinase B, which phosphorylates and thereby inactivates glycogen synthase kinase 3. This results in less phosphorylation of glycogen synthase; glycogen synthase itself will therefore be left in the dephosphorylated, active state.

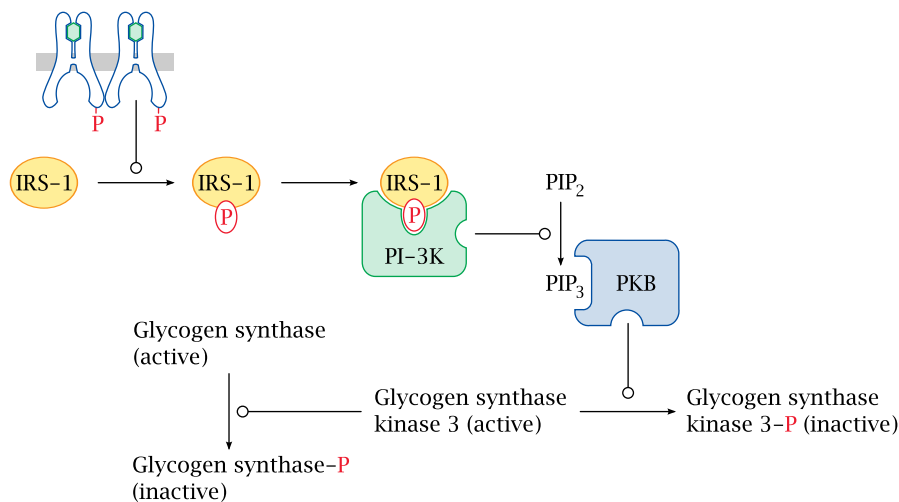

Insulin also activates phosphodiesterase, which lowers cAMP and thereby also affects the phosphorylation of glycogen synthase and of phosphorylase kinase (see slide 8.4.2). This effect is mediated via protein kinase B, too, but the exact molecular cascade from PKB to phosphodiesterase is not clear.



13.7 How does insulin affect glycogen metabolism?

13.2.15 The role of insulin in glucose transport

	Active transport	Facilitated transport
insulin-independent	small intestine, kidney tubules	brain, β -cells, red blood cells, cornea and lens of the eye
insulin-dependent	never	muscle, fat, most other tissues

Notes: The brain must keep working at all times; it depends on glucose and can take it up from the blood with or without insulin. In contrast, most other tissues can more readily replace glucose with other energy-rich substrates. The uptake of glucose into the cells of those tissues depends on insulin. When glucose supply is low, insulin secretion drops as well. Glucose uptake by insulin-dependent tissues ceases, which preserves glucose for the brain.

If blood glucose drops to excessively low values—this state is called *hypoglycemia*—the brain will no longer manage to obtain enough glucose, which will lead to unconsciousness and can result in brain damage and death.

13.2.16 Insulin promotes glucose uptake by increasing the surface exposure of GLUT 4 transporters

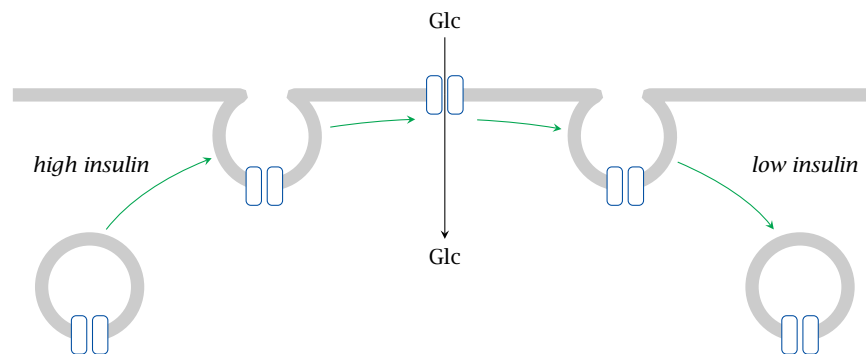

Notes: The distinction between insulin-dependent and -independent uptake correlates with different subtypes of the GLUT transporters. The major insulin-dependent type is GLUT 4, whereas GLUT 1 and 2 are insulin-independent. GLUT4 transporters undergo reversible translocation between the cytoplasmic membrane and intracellular storage vesicles. Obviously, only transporters currently residing in the cell membrane can transport glucose. The transporter migration is controlled through insulin-dependent phosphorylation of cytoskeletal proteins downstream of protein kinase B.

Insulin-independent transporters remain in the cell membrane throughout. In diabetes mellitus, cells with insulin-dependent glucose uptake will experience

glucose starvation, whereas those with insulin-independent uptake will be exposed to glucose overload.

 **13.8** How does insulin affect glucose transport?

13.2.17 Transcriptional regulation by insulin

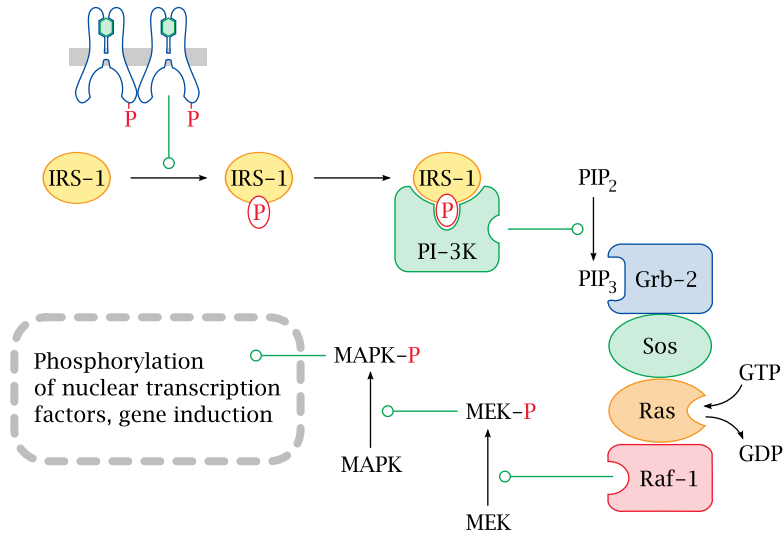

Notes: In addition to regulating the activity of pre-formed enzymes and transporters through phosphorylation, insulin also regulates the *de novo* expression of proteins at the level of transcription.

The participating proteins are numerous and all have suitably intriguing and cryptic names—for example, “Sos” is shorthand for “son of sevenless”—but we won’t go into details about them here.

13.3 Other hormones

N'-**H S Q G T F T S D Y S K Y L D S R R A Q D F V Q W L M N T**-C'

Glucagon

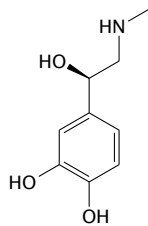

Epinephrine

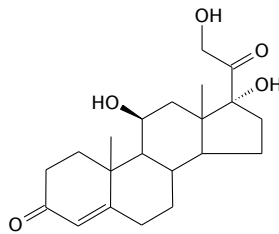

Cortisol

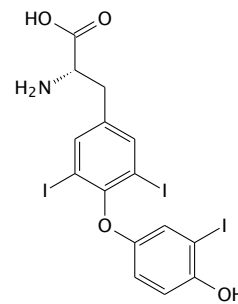

Triiodothyronine

Notes: Glucagon is a peptide hormone that is produced in the α -cells of the pancreatic islets. Epinephrine is produced in the medulla, and cortisol in the cortex of the adrenal glands. All these hormones are antagonists of insulin.

13.3.1 Glucagon and epinephrine act via G-protein-coupled receptors

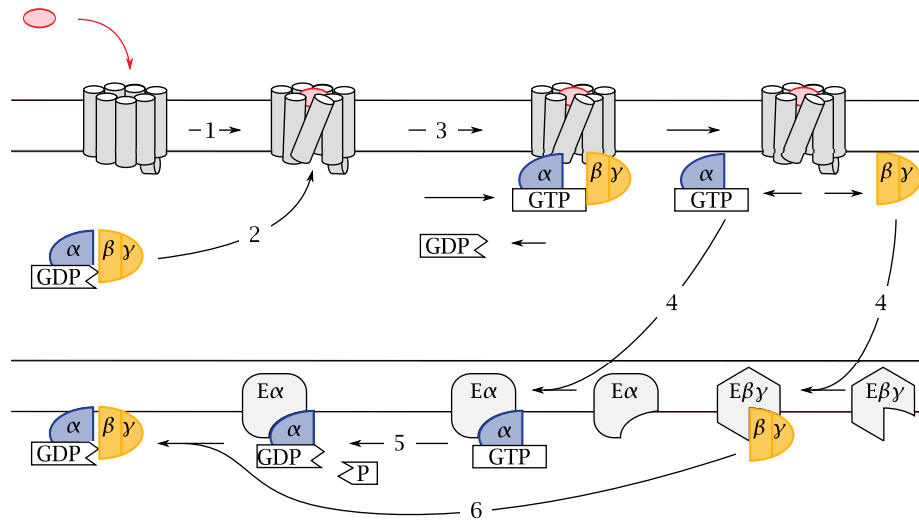

Notes: Glucagon and epinephrine act through cognate G protein-coupled receptors (GPCRs). Like receptor tyrosine kinases (RTKs), GPCRs are located in the cytoplasmic membrane. In contrast to RTKs, however, GPCRs do not have any enzymatic activity themselves. A GPCR functions solely by changing conformation in response to the binding of its cognate agonist, which occurs on the extracellular side (1). This conformational change is recognized on the intracellular side by a heterotrimeric G protein (2), which becomes bound to the receptor and is thereby activated. The active state of the G protein is stabilized by the non-covalent binding of GTP, which replaces a GDP molecule that was left behind in a previous round of activation (3). Upon GTP binding, the G protein dissociate into the α -subunit and the $\beta\gamma$ -dimer, each of which then seeks out its cognate effector protein (4).

The α -subunit has a built-in, slow GTPase activity. When this activity kicks in and cleaves the bound GTP molecule (5), the activated state is terminated,³ and the α -subunit rejoins a $\beta\gamma$ -dimer (6). The inactive trimer then awaits the next round of activation by the same or another GPCR molecule.

³The rate of GTP cleavage is modulated by special regulatory proteins, which we will not go into here. There just seems to be no end to the layers, convolutions and intricacies of signal transduction in cells; compared to it, metabolism is positively sane, simple and elegant.

13.3.2 The glucagon and epinephrine receptors activate adenylate cyclase and protein kinase A

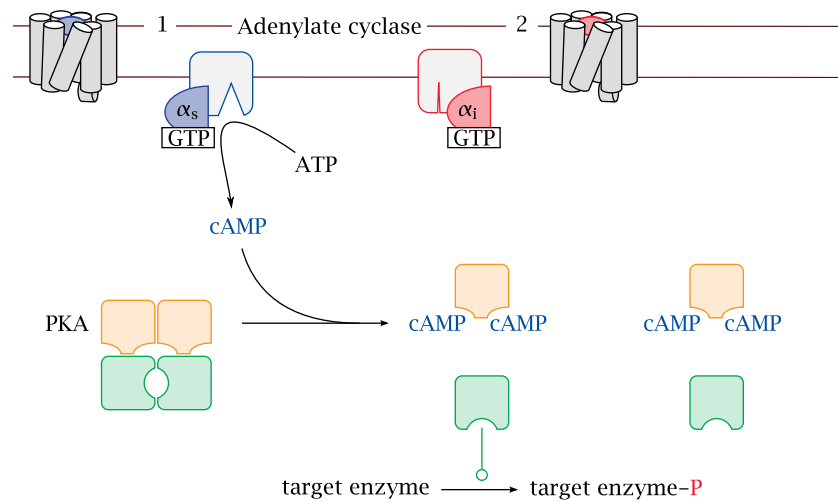

Notes: One type of G protein can couple to several types of GPCR; this is the case with the so-called stimulatory G protein (G_s), which couples to both the glucagon receptor and the β -adrenergic receptor, which binds epinephrine. The α -subunit of this G protein (α_s) activates adenylate cyclase, which converts ATP to cyclic AMP (cAMP). This second messenger then binds and activates protein kinase A (PKA), which phosphorylates a number of target enzymes.

Adenylate cyclase is also targeted by the α -subunit of an inhibitory G protein, G_i , which is activated downstream of other GPCRs, such as for example α_2 -adrenergic receptors or several serotonin receptor subtypes. Another major signaling cascade that is controlled by GPCRs is the phospholipase C/protein kinase C pathway, which is activated for example by vasopressin and oxytocin receptors. In these notes, however, we will confine the discussion to epinephrine, glucagon, and protein kinase A.

13.3.3 Metabolic effects of protein kinase A

Notes: This slide summarizes downstream effects of PKA activation that were already discussed in detail earlier. The roles of PKA in gluconeogenesis and in glycogen synthesis are shown in slides 7.5.4 and 8.4.2, respectively. PKA also activates hormone-sensitive lipase in fat tissue, which induces the release of free fatty acids and glycerol (slide 10.3.7).

Target	Effect	Metabolic consequence
glycogen synthase	↓	glucose is not locked up in glycogen, remains available
phosphorylase kinase	↑	phosphorylase is activated, glucose is released from glycogen storage
PFK-2 / Fructose-2,6-bisphosphatase	↓ / ↑	Fructose-2,6-bisphosphate drops; glycolysis is inhibited, gluconeogenesis is activated
hormone-sensitive lipase	↑	fatty acids will be mobilized for β -oxidation and ketogenesis

13.3.4 Glucocorticoids and thyroid hormones act on nuclear hormone receptors to activate transcription

Notes: While they are inactive, nuclear hormone receptors are located in the cytosol. When activated by ligand binding, they translocate to the nucleus and bind to cognate DNA sequences, recruit a number of other regulatory proteins (not shown) and ultimately induce the transcription of genes in the vicinity of their target DNA sequences.

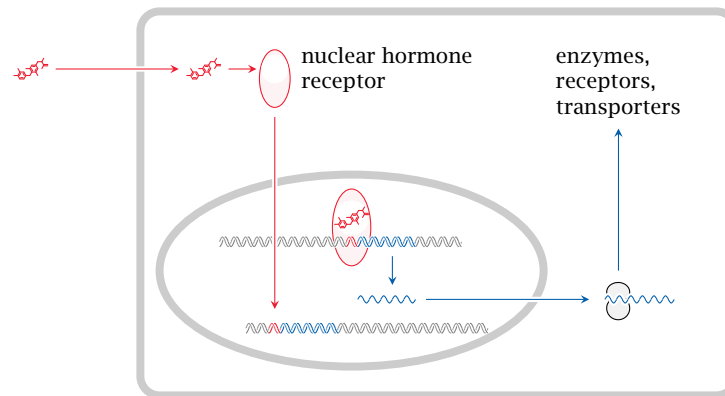

13.3.5 DNA binding by thyroid hormone receptors

Notes: Nuclear hormone receptors function as dimeric molecules. This picture illustrates the binding of a thyroid hormone receptor homodimer ($TR\beta$; left) and of a heterodimer of $TR\beta$ with retinoid X receptor (RXR; yellow) to specific target sequences in the DNA. The structures of the receptor molecules (rendered from [3m9e.pdb](#) and [2nll.pdb](#)) are not complete; the hormone-binding domains are missing, and only the DNA-binding domains are shown.

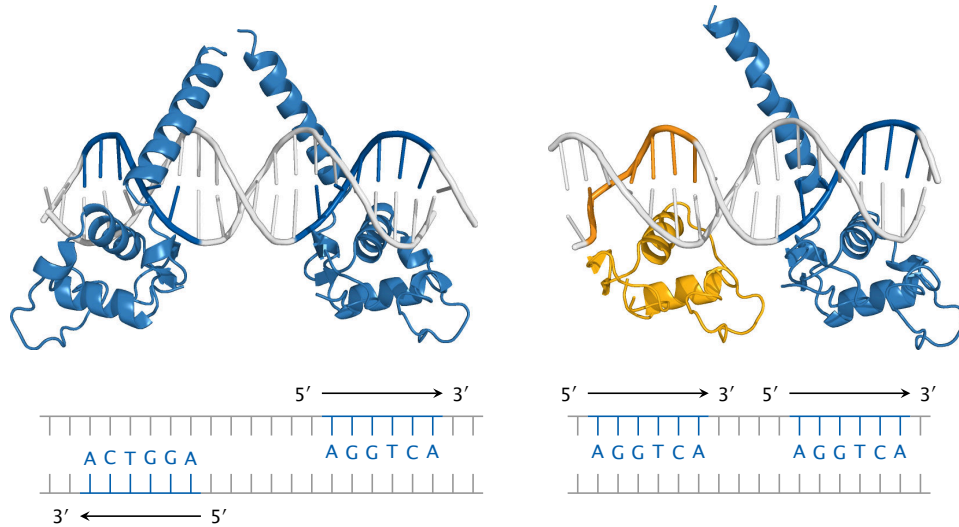

Note that TR β and RXR bind to the same hexanucleotide motif. Nevertheless, the two receptor dimers recognize different DNA target sequences, since the two instances of the hexanucleotide differ in orientation and spacing. Therefore, the two dimers bind to different sites on the DNA and control different sets of genes.

One key mechanism through which thyroid hormones affect energy metabolism is the transcriptional induction of mitochondrial uncoupling proteins. As discussed earlier (slide 6.3.1), uncoupling proteins mediate the conversion of metabolic energy to heat and therefore increase the burn rate of glucose and other energy-rich substrates. Nevertheless, thyroid hormones do *not* reduce blood glucose, since they also induce the expression of β -adrenergic receptors, and they therefore amplify the glucose-enhancing effect of epinephrine.

13.3.6 Metabolic effects of glucocorticoid hormones

- induction of enzymes for glycogen synthesis, glycogen breakdown, and gluconeogenesis
- induction of enzymes for protein breakdown, supplying substrates for gluconeogenesis
- induction of adrenergic receptors

... overall, glucocorticoids increase blood glucose

Notes: In addition to their role in metabolic regulation, glucocorticoids also inhibit inflammation and immune responses. They are used as drugs in the treatment of various inflammatory and autoimmune diseases; their metabolic effects then become unwanted side effects of such therapy.

13.3.7 Glucocorticoid receptor agonists and antagonists

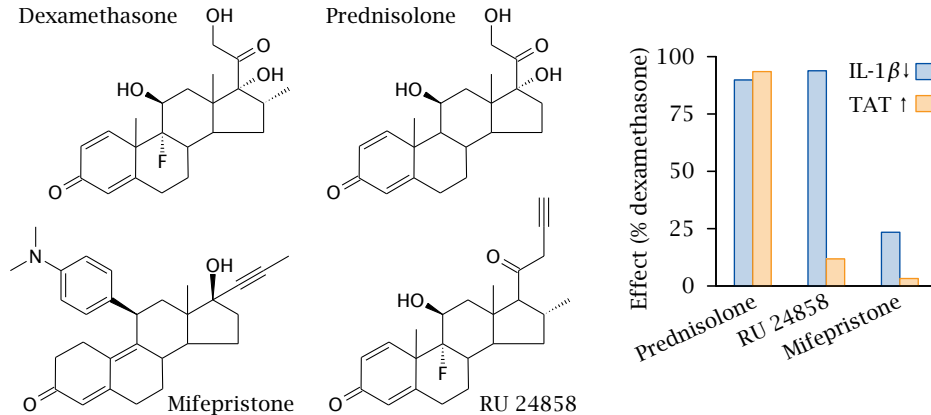

Notes: Dexamethasone and prednisolone are synthetic glucocorticoid receptor agonists that exert both antiinflammatory and metabolic effects. Mifepristone is a glucocorticoid receptor antagonist. In the experiment shown on the right, the activities of these conventional drugs were compared to those of the experimental drug RU 24858. Downregulation of interleukin-1 β (IL-1 β) measures antiinflammatory activity, whereas the activity of tyrosine transaminase (TAT), an enzyme that participates in amino acid degradation (see slide 12.4.5), represents metabolic regulation. Figure prepared from original data in [77].

With dexamethasone, prednisolone and mifepristone, the antiinflammatory and metabolic effects are similarly weak or strong. In contrast, with RU 24858, they are clearly distinct, suggesting that this drug selectively triggers the antiinflammatory glucocorticoid effect but avoids the side effects on metabolic regulation. Such selective glucocorticoid receptor agonists are promising but not yet in clinical use. The biochemical mechanism that underlies the dissociation of metabolic and antiinflammatory glucocorticoid effects is quite interesting [78].

Note that mifepristone is an antagonist not only at the glucocorticoid receptor but also at the progestin receptor; its typical medical applications relate to the latter activity.



13.9 How do thyroid hormones affect metabolic turnover?

13.3.8 Control of food intake by leptin



Notes: Leptin is a peptide hormone produced by fat tissue, in proportion to its abundance and current triacylglycerol content. It acts upon receptors in the hypothalamus and reduces appetite. This slide illustrates the effect of genetic knock-out of leptin in mice (no points for correctly identifying the knockout and the wild-type mouse).

While leptin is important in long-term regulation of metabolism and body weight, initial expectations that leptin substitution or leptin receptor agonists might be useful in the treatment of obesity in humans have not been fulfilled. It appears that in adipose patients there is no leptin deficiency, but rather an insensitivity to it, similar to the insensitivity to insulin in type 2 diabetes (see next chapter).

13.4 Answers to practice questions

13.1: Glucagon, epinephrine, glucocorticoids (cortisol), thyroid hormones

13.2: By surgically occluding the pancreatic duct, thereby inducing degeneration of the exocrine pancreas tissue, several weeks before recovering the pancreas.

13.3: Just kidding. (It lasted from 1936 to 1939—but I can promise it won't be on the exam.)

13.4: The C-peptide is produced by proteolytic processing of proinsulin. It is secreted along with insulin and has incompletely characterized hormone activity itself.

13.5: Sulfonylurea drugs bind to the sulfonylurea receptor in pancreatic β -cells and promote the closed state of the K_{ir} potassium channel associated with that receptor. This promotes membrane depolarization, calcium influx and insulin secretion. These drugs can be used in diabetes type 2.

13.6: It is a receptor tyrosine kinase. Binding of insulin causes association of two receptor molecules with mutual phosphorylation, and subsequently the phosphorylation of insulin receptor substrate (IRS) proteins.

13.7: Insulin activates phosphodiesterase, which lowers the level of cAMP. This results in a decreased phosphorylation of glycogen synthase, which is thereby activated, and of phosphorylase kinase and subsequently also phosphorylase, which is inactivated.

The phosphorylation of glycogen synthase is further reduced by way of phosphorylation and thereby inhibition of glycogen synthase kinase 3.

13.8: Insulin controls the surface expression of some, but not all GLUT transporters. When insulin levels are low, GLUT transporters in many tissues are removed from the surface and stored in intracellular vesicles, which reduces the rate of cellular glucose uptake. This affects fat tissue and skeletal muscle, but not the liver and the brain.

13.9: They induce mitochondrial uncoupling proteins, which uncouple the electron transport chain from ATP synthesis. This means that substrate oxidation is no longer restricted by the rate of ATP synthesis and therefore is increased.

Chapter 14

Diabetes mellitus

14.1 Introduction

Apart from atherosclerosis, diabetes mellitus is the most common metabolic disease. It is caused by an absolute or relative lack of insulin activity, which disrupts the regulation and balance of many metabolic pathways. Examining the pathogenesis of diabetes is instructive and a good opportunity for us to recapitulate what we have learned so far.

14.1.1 What's in a name?

1. diabetes: “marching through”—urine is produced incessantly
2. mellitus: honey-sweet—as opposed to *diabetes insipidus* (insipid—without flavor)

What does the adjective tell us about a traditional method of diagnosis?

Notes: The traditional method of diagnosis was exactly as suggested by this nomenclature. It was effective, though not quantitative. For those of you who aspire to a career in medicine, it may be comforting to know that it is no longer in use.¹

¹Diabetes insipidus is due to the lack of anti-diuretic hormone (ADH), a peptide secreted from the posterior hypophyseal gland. This hormone promotes the retention of water by reuptake in the collecting duct section of the nephron (see below). Loss of ADH production, typically due to a lesion of the hypophyseal gland, results in a dilute urine, but without loss of glucose or other metabolites.

14.1.2 Forms and causes of diabetes mellitus

Notes: Type 1 diabetes is the form typically observed in the young, whereas the type 2 is more frequent overall and is typically observed in the elderly. MODY—maturity type onset diabetes of the young—is type 2 diabetes in young people.

Form	Cause
type 1	lack of insulin due to destruction of β -cells in pancreas islets
type 2	lack of functional response to insulin
secondary	excess activity of hormones antagonistic to insulin

The causation of diabetes type 1 is well understood: it arises from an immunological cross-reaction that destroys the insulin-producing β -cells of the pancreatic islets, which causes a lack of insulin. In contrast, type 2 diabetics may secrete normal, sometimes even increased amounts of insulin. The hormone also binds to its receptors on the cells in the body, which however fail to respond adequately to this stimulus. In spite of substantial research efforts over several decades, we still don't clearly understand the reasons for this lacking functional response.

Secondary, or symptomatic, diabetes is diverse. A straightforward example is the excessive secretion of glucagon by a *glucagonoma*, that is, a benign tumor derived from glucagon-secreting α -cells in pancreatic islets. More commonly, though, secondary diabetes is caused by treatment with high dosages of glucocorticoid hormones in the treatment of auto-immune diseases.

14.2 Mechanism of renal glucose loss

The loss of glucose with the urine is a consequence of too high glucose blood levels, which result from the failure of uptake and utilization by insulin-dependent tissues, as well as from various kinds of metabolic dysregulation (see below).

Renal glucose loss is not the most severe symptom of diabetes, but it is nevertheless a prominent one. In order to understand how it comes about, we will first take a look kidney function. This will also provide useful background for some topics in later chapters.

14.2.1 Overview of kidney function

Urine is “distilled” from blood plasma in several stages:

1. ultrafiltration: 10-20% of the blood plasma volume that passes through the kidneys is squeezed across a molecular sieve; small solutes are filtrated, macromolecules are retained

2. solute reuptake: glucose, amino acids, salts etc. are recovered from the ultrafiltrate through active transport
3. water reuptake: driven by osmotic gradient
4. solute secretion: some substrates are actively secreted into the nascent urine

Notes: Blood flows through the kidneys at a rate of $\sim 1.2 \text{ l/min}$, or $\sim 1700 \text{ l/day}$. A bit more than half of that volume is blood plasma, and if we assume a plasma filtration rate of 15%, we obtain a filtrate volume of approximately 150 l/day . Obviously, therefore, most of the water and of the solutes contained in the filtrate must be reclaimed, and only the leftovers appear in the final urine. On the other hand, some solutes are secreted into the nascent urine only after filtration.

14.2.2 The nephron

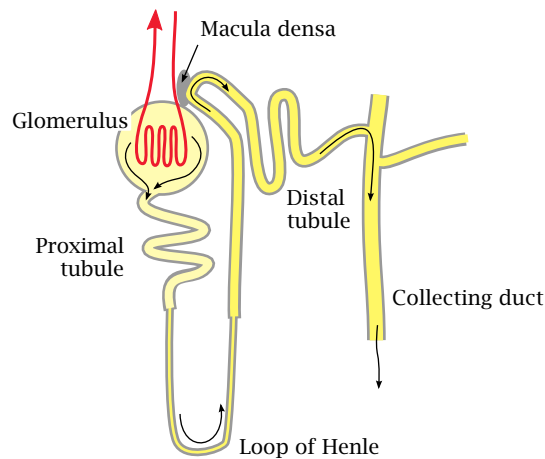

Notes: Just as the liver consists of many lobules that each comprise the whole organ function in a small microcosm, the kidney also consists of many instances of a repeating functional unit, the *nephron*, that comprises all stages of urine production. Each of the two kidneys contains ~ 1.3 million nephrons that all work in parallel.

A nephron consists of a glomerulus and a tubular part that can be divided into the proximal tubule, the loop of Henle, and the distal tubule; the latter joins a collecting duct that drains several nephrons towards the exit.

The primary filtrate is formed in the glomerulus. It flows into the proximal tubule, where glucose, amino acids, and most of the salt ions are reclaimed by specific active transporters; water follows by osmosis. More water is reclaimed in Henle's loop. Along this stretch, a very high salt concentration prevails in the interstitial space of the surrounding tissue, which allows the nascent urine to become significantly more concentrated than blood plasma. Fine tuning of urine concentration, pH and salt content occurs in the distal tubule.

Reuptake of glucose in the nephron occurs through sodium-coupled active transport. The number and capacity of the transporter molecules in the proximal tubules is limited.

14.2.3 Kidney tissue structure and function: Glomeruli and tubules

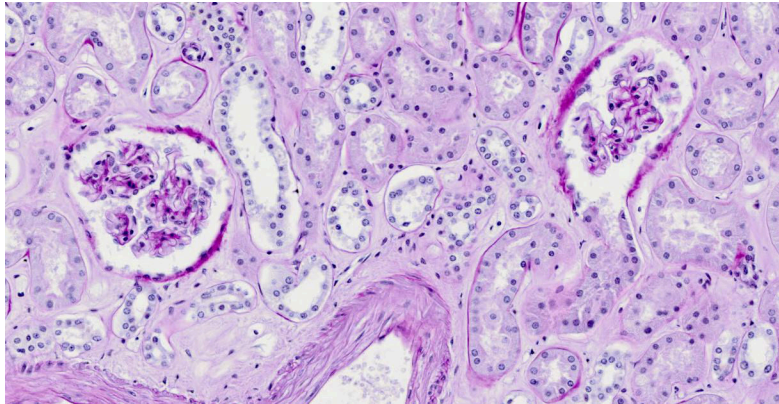

Notes: The tissue section shows two glomeruli, surrounded by cross sections of various types of tubules. The sheath containing each glomerulus is known as Bowman's capsule. In the glomerulus on the right, the capsule has been cut away where it opens into the proximal tubule.

14.2.4 Primary filtration occurs in the glomerulus

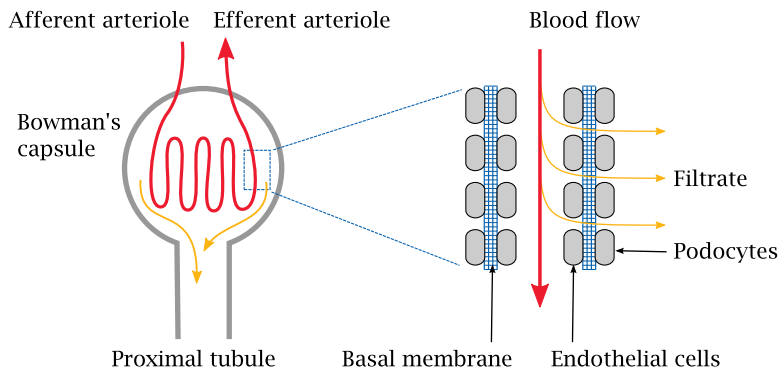

Notes: The glomerulus contains a coiled *arteriole*, that is, a small artery. Unlike the arterioles in the remainder of the body, the endothelium of these glomerular arterioles has gaps. The endothelial gaps line up with gaps in a second cellular layer that is formed by the so-called podocytes and surrounds the outer side of the basal membrane of the arteriole. As with the capillaries in the general circulation, it is the basal membrane that forms the actual molecular sieve in the filtration. The molecular weight cutoff for filtration is similar, too: molecules with less than 10 kDa get across, whereas larger ones are retained. For small molecules that are not retained in the plasma by protein binding, the concentration in the filtrate will be the same as in the plasma. In contrast, proteins and other large molecules should be quantitatively retained inside the arteriole. If proteins do appear in the urine in significant amounts, this indicates that the filtration apparatus is damaged, as is the case for example in *glomerulonephritis*, an autoimmune disease.

Glomerular filtration is driven by the hydrostatic pressure gradient across the wall of the arteriole. In regular capillaries, the hydrostatic pressure is fairly low, and since it is almost entirely balanced by the osmotic activity of the plasma proteins, very little net filtration occurs (see slide 10.2.4). In contrast, the hydrostatic pressure within the glomerular arterioles is much higher, and therefore filtration proceeds apace.

14.2.5 Reuptake and secretion occur in the tubular segments

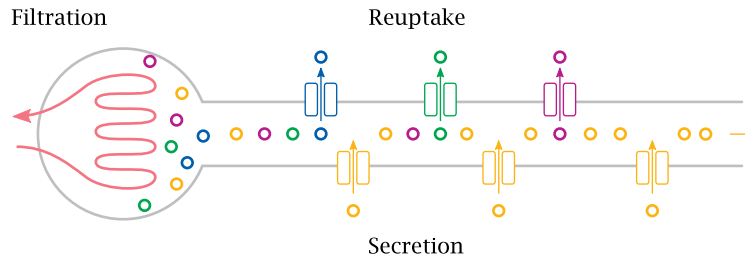

Notes: The bulk of the metabolites, including glucose, and most of the water are taken up again in the proximal tubule of the nephron. Other metabolites, such as uric acid (slide 16.5.4), are secreted into the urine in the proximal tubule by active transport. The distal segments of the tubule are concerned with fine-tuning the urine volume, and with the secretion or retention of salt ions and protons according to the currently prevailing metabolic situation.

14.2.6 The capacity for glucose reuptake is saturated slightly above the physiological plasma concentration range

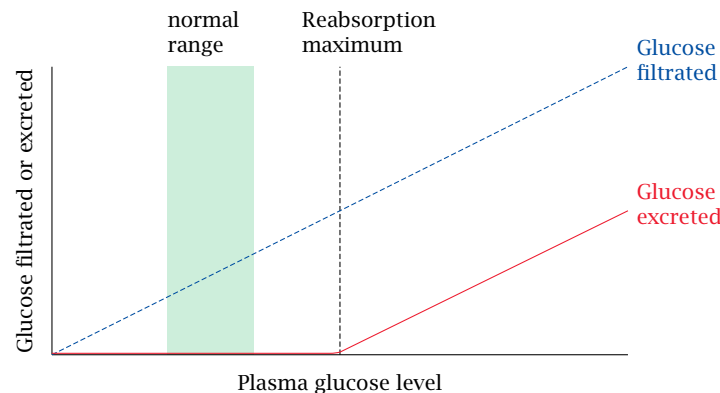

Notes: The normal range of glucose in the blood is approximately 4–7 mM. Glucose starts to appear in the urine when the plasma glucose level exceeds the reabsorption maximum of ~10 mM. This level is easily exceeded in untreated or inadequately treated diabetics, who are therefore prone to glucosuria. If glucose is detected in the urine, this means that at some time during the last couple of hours the blood glucose must have exceeded the reabsorption threshold. Testing

for glucose in the urine can thus be useful in assessing the stringency of glucose control in a patient.

Due to its osmotic activity, glucose excreted in the urine will also cause an increase in the urine volume; this effect is referred to as *osmotic diuresis*.²

14.3 Metabolic dysregulation in diabetes mellitus

14.3.1 Lack of insulin drives up cAMP

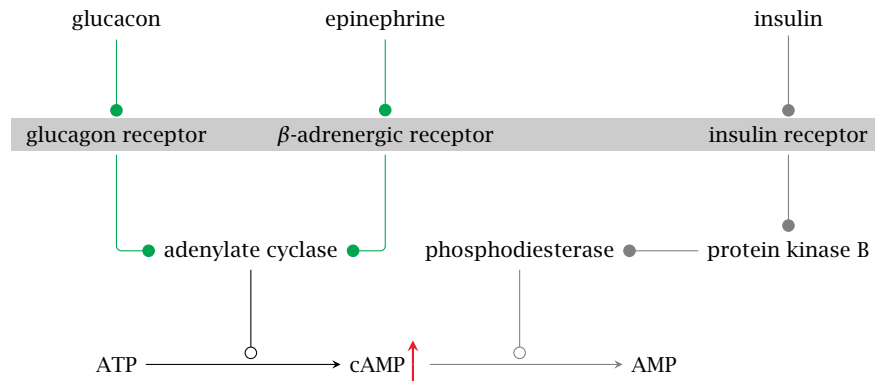

Notes: Many metabolic pathways are regulated by the balance between glucagon and epinephrine on the one hand and insulin on the other. The level of the intracellular second messenger cyclic AMP (cAMP) is a key parameter that represents this balance. Glucagon and epinephrine activate adenylate cyclase, which forms cAMP, whereas insulin activates phosphodiesterase, which cleaves cAMP. If insulin is lacking or insulin sensitivity is diminished, the level of cAMP will go up, and protein kinase A (PKA) will be activated.

As we have seen, one of the target proteins controlled by cAMP and PKA is the bifunctional enzyme phosphofructokinase-2/fructose-2,6-bisphosphatase. Phosphorylation of this enzyme activates the bisphosphatase, which lowers the level of fructose-2,6-bisphosphate (see slide 7.5.4). This inhibits glycolysis and activates gluconeogenesis (see slide 7.5.3).

Excessive cAMP levels also affect glycogen metabolism, such that glycogen synthesis is inhibited and breakdown is increased (see slide 8.4.2). Therefore, even though blood glucose is already high to due to lack of cellular uptake in peripheral tissues, both gluconeogenesis and glycogen breakdown in the liver are activated, producing more glucose and further compounding the excessive glucose accumulation.



14.1 How does diabetes affect the rate of gluconeogenesis?

²Osmotic diuresis can also be induced with other solutes. The sugar alcohol mannitol has been used in this manner to speed up the elimination of drugs and poisons, but this treatment appears to be no longer in common use.

14.3.2 Lack of insulin induces triacylglycerol breakdown in fat tissue

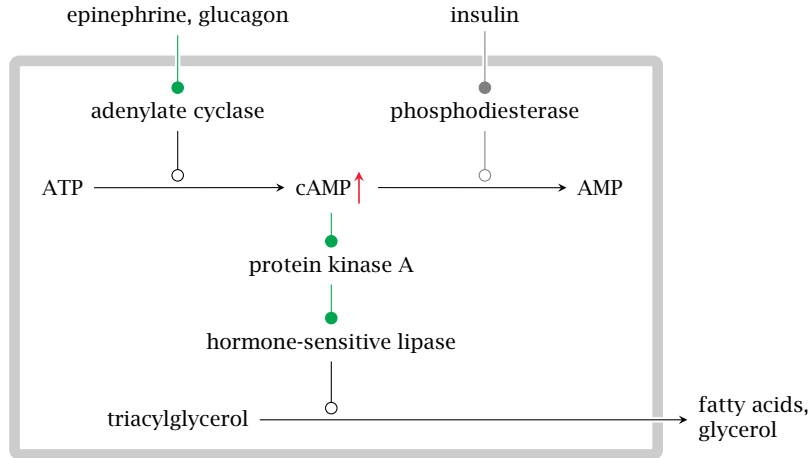

Notes: The cAMP/PKA cascade also activates the hormone-sensitive lipase in fat tissue. This enzyme initiates the breakdown of triacylglycerol to free fatty acids and glycerol, which are then released into the blood stream. Glycerol will feed into gluconeogenesis in the liver. Fatty acids may be directly consumed or feed into ketogenesis in the liver.

14.3.3 Lack of insulin induces protein breakdown in muscle tissue

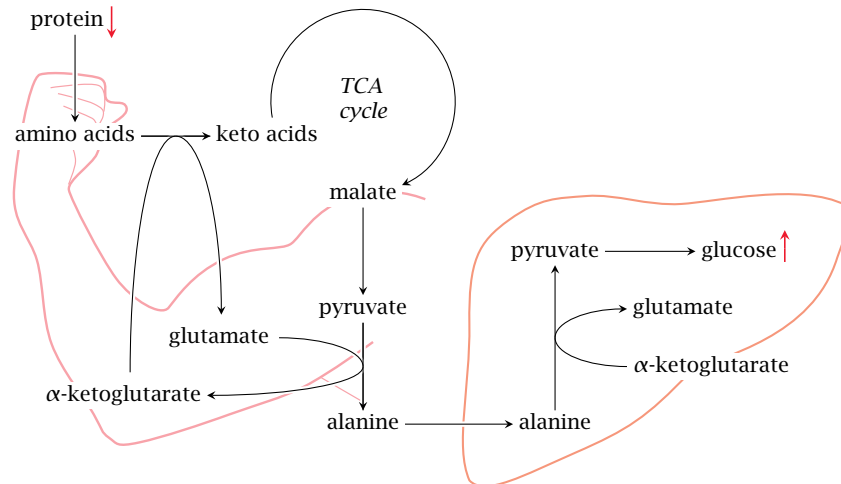

Notes: In skeletal muscle, the lack of insulin prevents uptake of glucose, which creates a need for alternative sources of energy. In part, this need is filled by fatty acids and ketone bodies, but additionally protein degradation is activated.³

The amino acid released by protein breakdown also enter degradation. As we have seen, many amino acids are converted to pyruvate or to TCA cycle intermediates (slide 12.1.2); the latter can also be converted to pyruvate by malic enzyme

³Indeed, protein degradation is activated beyond the muscle's own metabolic need by signaling pathways that also cause muscle wasting in chronic inflammation and cancer [79].

(see slide 9.3.2). Pyruvate is transaminated to alanine, which travels to the liver and enters gluconeogenesis. Alanine formation and transport to the liver also occur as part of the glucose-alanine cycle (slide 12.3.5). The difference between the regular function of that cycle and the catabolic situation in untreated diabetes is that glucose cannot reenter the muscle cells; this greatly accelerates the loss of substrate carbon from muscle.



14.2 What happens to protein metabolism in muscle in diabetes?

14.3.4 Substrate overload in the liver leads to ketogenesis and lipoprotein synthesis

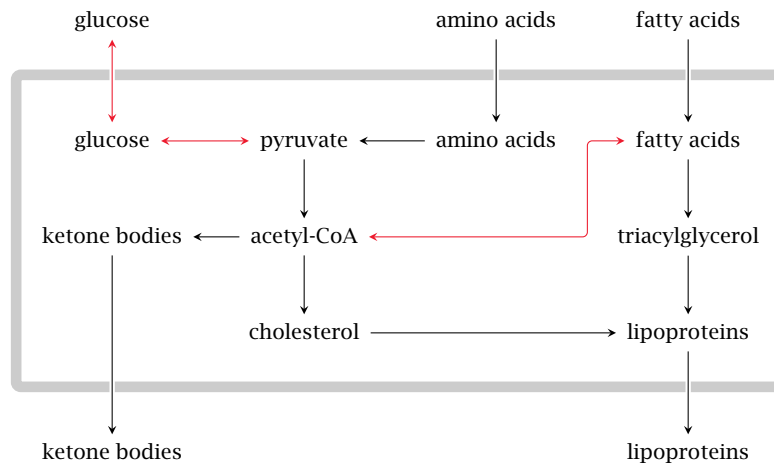

Notes: The various causes of glucose accumulation, as well as the accelerated degradation of fat and protein in peripheral tissues, cause a general substrate overload in the liver. At some point, the level of glucose will be so high that glycolysis resumes and pyruvate dehydrogenase starts turning out acetyl-CoA. Some of the free fatty acids mobilized in the fat tissue undergo β -oxidation and produce more acetyl-CoA, whereas others are converted again to triacylglycerol.

A large share of the excess acetyl-CoA is converted to ketone bodies, which will reach plasma levels far beyond those that occur physiologically during starvation. Some acetyl-CoA is converted instead to cholesterol, which together with triacylglycerol is packaged into lipoproteins. The lipoproteins are released into the bloodstream. Elevated blood lipids are a typical finding and contribute to the accelerated development of atherosclerosis in insufficiently treated diabetics.

14.3.5 Laboratory findings in untreated or under-treated diabetes

Notes: Ketone bodies are fairly strong acids. The kidneys normally compensate for the accumulation of ketone bodies in the blood through the secretion of protons in the form of ammonium chloride. However, the excessive rate of ketogenesis

in acute diabetes tends to overwhelm the capacity of the kidneys to balance the blood pH. The condition is referred to as ketoacidosis.⁴

Observation	Cause
increased blood glucose	excessive gluconeogenesis, lack of utilization
glucose excreted in urine	capacity for renal reuptake exceeded
acidosis (low blood pH)	high plasma levels of ketone bodies
increased urea levels	accelerated muscle protein breakdown
increased blood lipoproteins	increased synthesis and packaging of cholesterol and triacylglycerol in the liver

 **14.3** What is acidosis, and what causes acidosis in untreated diabetes?

14.3.6 Typical symptoms and history in a new case of type 1 diabetes

Symptom	Cause
dehydration	osmotic diuresis due to glucose excretion
acetone smell	acetone forms from acetoacetate, is exhaled
coma	both acidosis and blood hyperosmolarity impair brain function
loss of body weight	dehydration, breakdown of proteins and fat
recent flu-like disease, possibly myocarditis	coxsackievirus infection

Notes: In addition to dehydration and pH deviation, one might consider high acetone levels as an additional cause of diabetic coma, since acetone has documented narcotic activity [80, 81]. This possibility has been considered in a study on several patients that had experienced diabetic coma [50]; the authors concluded that plasma acetone levels in these patients fell short of narcotic concentrations.

 **14.4** How is acetone formed in diabetic metabolism, and what is its significance?

⁴Other possible forms of acidosis are accumulation of lactate (lactic acidosis) and respiratory acidosis, which is due to insufficient removal of CO₂ through the lungs. Lactic acidosis can be induced by oral metformin and related oral antidiabetic drugs (see slide 14.5.14).

14.4 The role of coxsackieviruses in the pathogenesis of type 1 diabetes

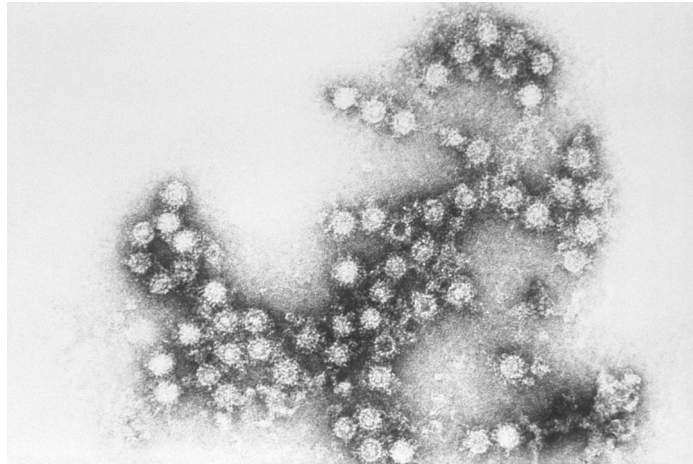

Notes: Coxsackieviruses belong to the enterovirus group, like hepatitis A virus and poliovirus. These viruses contain a single-stranded RNA genome and are “naked”, that is, they do not possess a lipid envelope.

Coxsackieviruses can cause non-specific febrile disease but occasionally give rise to *pleurodynia*, which is characterized by chest pain during breathing that results from the infection of muscles in the rib cage. These viruses may also cause *myocarditis*, that is, an infection of the heart muscle. You will not be surprised to hear that, of the two, myocarditis is the much more serious condition.

The involvement of coxsackieviruses in the pathogenesis of type 1 diabetes is *not* due to direct damage to the pancreatic β -cells by the virus; instead, it arises from an immunological cross-reaction between viral antigens with cellular antigens found in the β -cells.

14.4.1 Outline of T lymphocyte function in antiviral immune responses

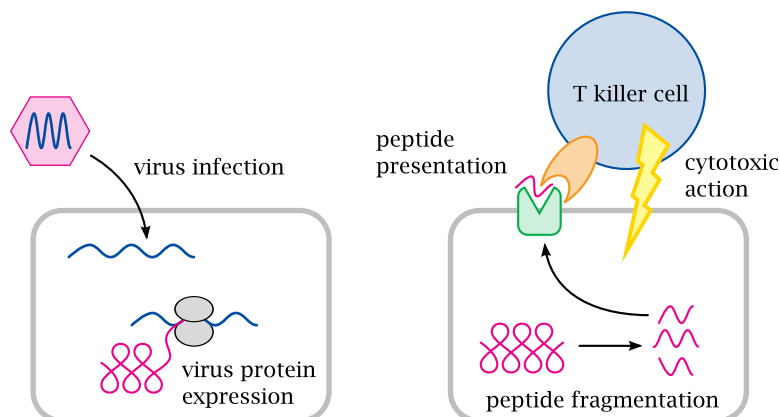

Notes: The eradication of viral infections involves *cellular immunity*, which is mediated mostly by T-lymphocytes. These cells occur in several variants, namely

- T-helper cells,
- T-suppressor cells, and
- T-killer cells (cytotoxic T cells).

The interaction between lymphocytes and other nucleated cells that enables the lymphocytes to recognize and eliminate virus-infected cells is controlled by two protein molecules. These two proteins are the HLA molecules, which we find on all nucleated cells, and the T cell receptors, which occur only on T lymphocytes.

HLA molecules present potentially antigenic peptides to the T cell receptors. These peptides are samples drawn randomly from the entire set of cellular proteins: As proteins undergo turnover and degradation within the cell, some of the ensuing peptide fragments will become bound to HLA molecules and be transported to the cell surface.⁵ If the cell is not infected by a virus, these surface-exposed peptides will all be fragments of human-encoded proteins; on the other hand, if the cell is virus-infected, a lot of these peptides will be of viral origin.

The HLA-associated peptides are recognized by T cell receptors. These receptors occur in very many variants that differ in antigen specificity. The variants are produced through combinatorial rearrangement of DNA fragments in the corresponding genes of the T cells, which means that all receptor molecules found on a given T cell, as well as on all of its daughter cells, will be identical.⁶

Since a T cell receptor arises through a randomized DNA recombination process, its antigen specificity is also random; it may have affinity for a self antigen, that is, a macromolecule that occurs normally in the body and has every right to be there, or for a non-self antigen such as viral protein. Any T lymphocytes that recognize self antigens are normally weeded out by the immune system itself; this is the role of the T suppressor cells.⁷ In contrast, T helper cells and T killer cells that have no auto-reactive specificity are allowed to persist, since they may have useful affinity for non-self antigens such as viral proteins. Once such a T cell comes across another nucleated cell that happens to present its cognate antigenic peptide, it will bind to this cell and attack it. The T cell-mediated killing of virus-infected cells is a key process in antiviral immune defense.

The random generation of T cell clones with novel antigen specificities may also produce cross-reactive clones that recognize both self antigens and viral antigens. Such clones will usually be suppressed, but occasionally an acute virus infection may intercede and cause them to proliferate before the suppression takes hold. This may then result in damage to cells that express the cross-reacting self antigen. Such a cross-reaction may occur between coxsackieviruses and some self

⁵The abbreviation HLA stands for human leukocyte antigen, but HLA molecules are found on all nucleated cells, not just leukocytes. They are, however, not found on red blood cells, which have no protein synthesis and thus no use for HLA molecules. HLA molecules are very diverse between individuals; this is what makes them antigens. Their absence on red blood cells explains why blood transfusions are far less fraught with immunological incompatibilities than are organ transplants.

⁶A similar mechanism also produces the clonal variation of antibody specificities in B lymphocytes.

⁷Failure of the T suppressor cells to eradicate autoreactive T helper or T killer cells will result in autoimmune diseases.

antigens of pancreatic β -cells, causing the destruction of β -cells and giving rise to type 1 diabetes.

14.4.2 Structure of a T cell receptor bound to its cognate peptide presented by an HLA molecule

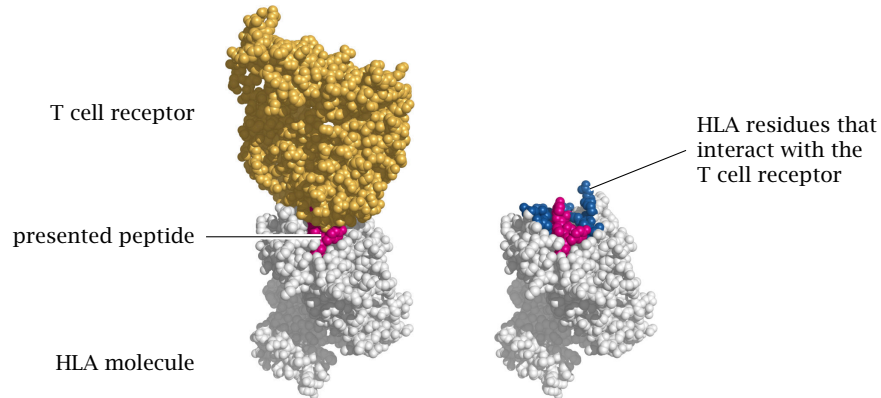

Notes: When a T cell receptor binds to an antigenic peptide, it really recognizes the complex of the HLA molecule and the peptide, not just the presented peptide alone. This means that the HLA antigen may augment or reduce the affinity of T cells for the peptide, and thereby modulate the strength of the immune reaction. This holds both for regular immune reactions against viruses or other microbes⁸ and for autoimmune reactions such as that affecting pancreatic β -cells. Therefore, the risk of developing type 1 diabetes varies substantially between different HLA genotypes. Structures rendered from [1ao7.pdb](#).



14.5 Which infectious agent induces the immunological cross-reaction that leads to the destruction of pancreatic β -cells in diabetes type 1?

14.4.3 HLA alleles influence the risk of developing type 1 diabetes

HLA-DQ Haplotype	Relative risk	Absolute risk
A1: 0301-0302 / B1: 0501-0201	21	6%
B1: 0602	0.03	0.01%

Notes: The alleles and associated risks listed here are just one illustrative example of the influence of HLA genotypes on the risk of contracting type 1 diabetes. The relative risks are calculated to the average risk of the population; the absolute risks represent the probabilities of contracting type 1 diabetes for persons carrying the allele in question. Note that 94% of the individuals with the high-risk allele will *not* contract diabetes.

⁸The diversity of HLA antigens among humans is believed to have arisen through the exposure to different infective agents that selected for different HLA antigens. Association of specific HLA alleles with protection from infection is documented for various pathogens, including HIV [82].

14.5 Therapy of diabetes

14.5.1 How to treat a fresh case of acute diabetes

1. Severely sick, possibly comatose patient
 - infusion therapy for fluid replacement, pH and electrolyte adjustment
 - parenteral nutrition with proportional insulin substitution
 - frequent monitoring of lab parameters (glucose, salts, pH) to adjust therapy
2. Upon stabilization
 - reversal to oral nutrition
 - train patient to adhere to a stable, regular diet and inject themselves with insulin
 - teach patient to monitor blood glucose and to recognize symptoms of hyper- and hypoglycemia

Notes: New, untreated cases of diabetes present themselves with different degrees of clinical urgency. The acute illness and coma scenario is more likely to occur in diabetes type 1 than type 2, since in the former insulin secretion subsides acutely, whereas in the latter things tend to go downhill more slowly. Acutely ill patients will require both phases of treatment outlined in this slide, whereas others will seek treatment at less advanced stages and can enter the second stage of treatment right away.

Acutely sick diabetes patients typically have lost a lot of fluid and salts. They are likely in *acidosis*, that is, their blood pH is too low due to the accumulation of ketone bodies. All these deviations must be corrected by infusion therapy. Insulin is initially administered with the infusion. All components of the infusion, and the flow rate of the infusion itself, are adjusted according to frequent laboratory tests.

When the acute situation has been brought under control, the infusion therapy is terminated and the patient is returned to oral nutrition. The next task is to find out how much insulin this individual patient needs to match their appropriate caloric intake. This usually takes a few weeks of experimentation. Once an appropriate schedule for diet and insulin injections has been worked out and the patient has been properly trained, they can be discharged, which is followed by initially frequent ambulant supervision.



14.6 Which problems need to be addressed in the treatment of an acute case of type 1 diabetes?

14.5.2 Kinetics of physiological insulin secretion

Notes: The blood level of insulin rises up rapidly immediately after a meal and then slowly declines over a time course of several hours. The slow pace of the decline is due to sustained secretion of insulin at slowly decreasing rates; individ-

ual insulin molecules that have been secreted into the plasma decay much faster, with a half-life of only ~15 minutes. This rapid inactivation is brought about by peptidases in the blood plasma. If we simply inject insulin intravenously, it will be just as rapidly degraded as the endogenously secreted hormone; in fact, this is what happens to insulin that is applied with the infusion treatment in the acute stage.

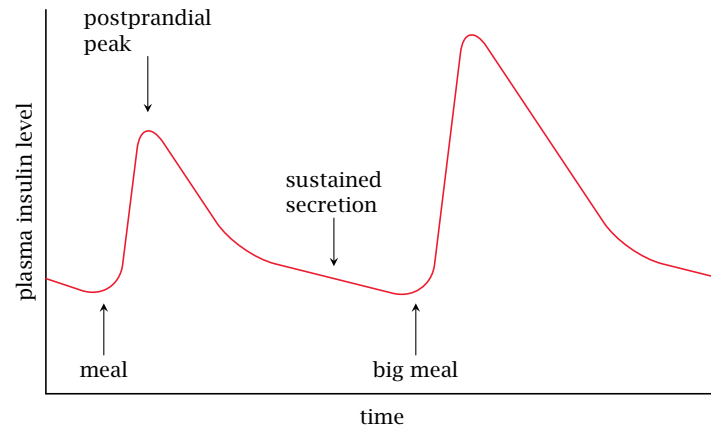

Continuous infusion is, of course, not practical for long-term treatment; instead, we need a way to mimic the slow, protracted changes of the physiological insulin profile with a limited number of injections per day. The following slides illustrate how this is accomplished.

14.5.3 The reversible aggregation of insulin delays its diffusion from tissue into the circulation

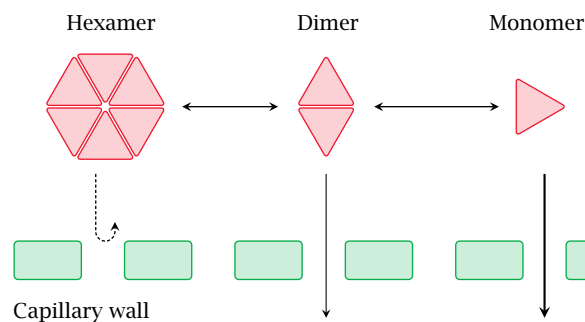

Notes: When we inject the insulin into the tissue (typically into the subcutaneous fat tissue—not into the cells, but rather into the fluid-filled *interstitial* space in between) instead of intravenously, insulin has to diffuse across the walls of the capillaries to reach the circulation, which will occur in a protracted fashion. At high concentration, the extravascular insulin will form hexameric complexes, which are too large to freely diffuse across capillary walls; the required dissociation into dimers and then monomers will further delay the uptake.

The extent of insulin aggregation varies with the ion composition and pH in the preparation. For example, zinc ions stabilize the hexamer, and a low pH induces

aggregation of hexamers into larger complexes, from which the insulin will take even longer to fully dissociate. These effects can be used to tweak the intended rate of uptake in clinically used insulin preparations.

14.5.4 Delayed release of insulin from protamine complexes

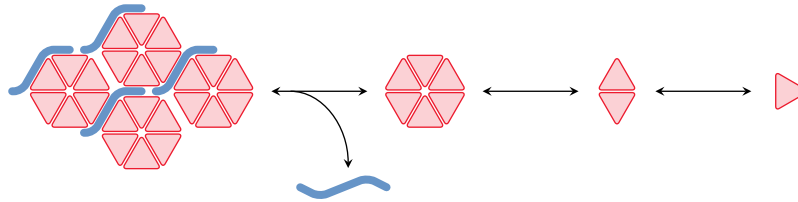

protamine MARYRCCRSQSRSRYRQRQRSRRRRRRSCQTRRRAMRCCRPRYPRCRRH

Notes: Another effective trick for tweaking the rate of release of insulin is to complex it with *protamine*, a small, basic DNA-binding protein that occurs in sperm cells. Insulin itself is negatively charged at neutral pH; the two proteins simply cluster together due to ionic interaction.

While protamine complexes and other measures to promote insulin aggregation cause delayed and protracted uptake of insulin into the circulation, another useful technique is to derivatize insulin so as to increase its stability in the circulation. A derivative that has been christened “insulin detemir” carries a fatty acyl residue, which causes it to reversibly bind to albumin; in the albumin-bound state, it is protected from degradation by circulating peptidases.



14.7 How does insulin aggregation affect the rate of systemic uptake of subcutaneously injected insulin?

14.5.5 Biphasic insulin preparations

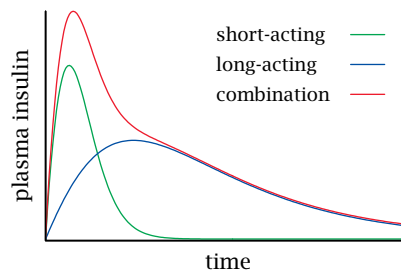

Notes: As pointed out above, insulin preparations can be tweaked and tuned for a faster or slower time course of action. In order to mimic both the steep increase and the slow decline of the physiological insulin secretion profile (see slide 14.5.2), fast-release and slow-release preparations are mixed into so-called biphasic insulins.

For many decades, biphasic and slow-release insulin preparations, applied two to three times per day, were most widely used in insulin substitution therapy.

However, the accuracy of glucose control that can be achieved with such regimens is limited, and the current trend favors more frequent insulin injections for tighter glucose control. While this is less convenient for the patient, it does help to avoid or postpone long-term complications of diabetes (see below).

14.5.6 Short-term complications of insulin-requiring diabetes

Deviation	Symptoms
insulin too low	hyperglycemia, acidosis, . . . , coma
insulin too high	hypoglycemia, coma

Notes: Insulin substitution treatment can go off the rails when the endocrine and metabolic situation of the patient changes, while the insulin dosage does not. For example, acute infections may drive up cortisol secretion, which in turn will raise blood glucose; on the other hand, loss of appetite, vomiting or diarrhea will reduce glucose uptake and blood levels.

In extreme cases, both low glucose levels (hypoglycemia) and excessively high ones (hyperglycemia) can induce coma. Among the two forms, hypoglycemic coma is more common and more immediately life-threatening. Therefore, in case we should find a comatose patient with known diabetes, and we are unable to determine whether he is hyper- or hypoglycemic—a largely hypothetical case now that glucose meters have become ubiquitous—we would inject glucose first. If the patient wakes up, the patient was indeed hypoglycemic; if not, we would assume the opposite and would then try insulin.

14.5.7 Long-term complications of insulin-requiring diabetes

Biochemical deviation	Clinical manifestation
accumulation of sorbitol in the lens of the eye	cataract
increased conversion of glucose to lipids	increased blood fats, atherosclerosis
glucosylation of proteins? sorbitol accumulation?	damage to nerve fibres, kidneys, other organs

Notes: Long-term complications of diabetes typically develop several decades after the onset of diabetes itself. They affect a multitude of organs, most notably the vasculature, the peripheral nervous system, and the kidneys. Among these complications, the causation of cataract by sorbitol accumulation is quite well understood (see slide 4.4). Sorbitol accumulation has been suggested as a mechanism in nerve cell damage also, but the evidence is less clear; aldose reductase inhibitors like tolrestat so far have not demonstrated unequivocal clinical benefits

[83]. Elevated blood lipids (slide 14.3.4), protein glycosylation (slide 11.6.7), and lack of C-peptide [76] are other potential mechanisms of long-term tissue damage.

Even though the biochemical mechanisms that underly the pathogenesis of diabetic long term complications are not fully understood, it has been observed that the severity of the clinical picture correlates with the cumulative extent and duration of upward deviations in the blood glucose level.

In the early days of insulin substitution therapy, the blood glucose used to be adjusted to levels somewhat above the normal range; this was done in order to prevent hypoglycemia, which could be acutely life-threatening. However, while sufficient to prevent acute symptoms, this approach favors the occurrence of long-term complications. Intensive insulin therapy (slide 14.5.9) addresses this problem.

14.5.8 HbA_{1C} as a parameter of long-term glucose control

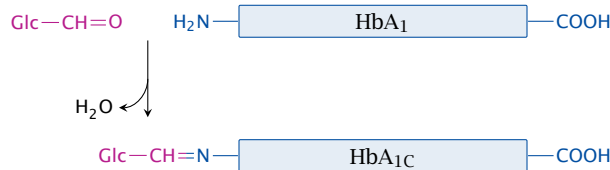

Notes: Glucose exists in an equilibrium between the ring-shaped hemiacetal form and the open chain aldehyde form (see slide 3.1.2). The aldehyde form can react with free amino groups of proteins. Among the latter, the N-terminal α -amino group has a lower pK_a and therefore is more reactive than the ϵ -groups of lysine side chains.

Protein glycosylation has been considered as a mechanism leading to the development of diabetic long-term complications, but the evidence is scarce. Whether or not it has a direct role in pathogenesis, it can be used as a diagnostic marker for assessing the metabolic adjustment in diabetic patients. Glycosylation is a slow reaction and occurs over weeks. Therefore, the extent of glycosylation of a long-lived protein such as hemoglobin will indicate how well-adjusted the glucose level has been, *on average*, for the last 4–6 weeks. This is useful to gauge the quality of metabolic control in patients during intervals between visits to the doctor.



14.8 What are common short term complications of diabetes? What are common long term complications? What are the underlying biochemical mechanisms?

14.5.9 Intensive insulin therapy

- rationale: prevent long term complications through tight control of blood glucose
- means: frequent glucose sampling and injections, or continuous insulin application with pump, such that the rate of insulin infusion is controlled by the current glucose level

- challenge: avoid hypoglycemia through insulin overdose—we need to minimize the delay between insulin application and effect

Notes: Intensive insulin therapy is increasingly accepted as the best form of treatment, particularly in young patients, who have the most to gain from the postponement of long term complications.

An obvious risk in this therapy is the accidental overdosing of insulin. To control this risk, we need to ensure that any amount of insulin that is applied is also promptly absorbed, so that it does not carry over beyond the time point of the next injection. Mutant insulins have been developed that have an increased rate of uptake. Note that this purpose is the exact opposite to that of preparations such as protamine insulin (see slide 14.5.4).

14.5.10 Nerdy intermission: delayed feedback causes signal oscillation

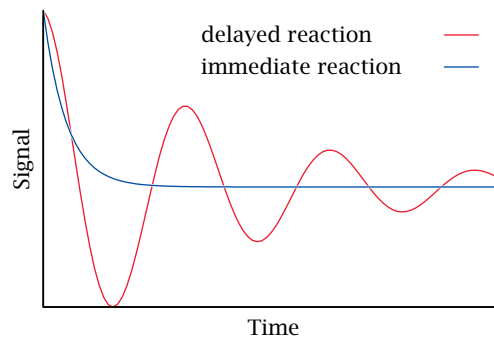

Notes: In regular physiology, the blood levels of glucose are connected by a negative feedback loop: As glucose rises, insulin rises and causes glucose to drop; conversely, a dropping glucose level will reduce the output of insulin, which then causes the glucose level to rise again.

Negative feedback loops operate in many places in metabolic regulation and ensure the homeostasis of metabolite levels. To be effective, the response of a negative feedback loop to changed input must be swift, since delayed feedback will cause overshooting corrections and induce oscillations.

In intensive insulin therapy, the ideal goal is to replace the function of the physiological glucose-insulin feedback loop. Apart from timely injections of insulin, this also requires that the injected insulin quickly reaches the bloodstream and becomes active. If the insulin effect takes hold too slowly after injection, this will cause delayed feedback and potentially dangerous oscillations of the glucose level.

14.5.11 Structural basis for proline B28 mutations

Notes: Several insulin mutants optimized for rapid uptake contain substitutions of the proline residue in the 28th position of the B chain. The effects of these mutations can be understood from the structure of insulin aggregates.

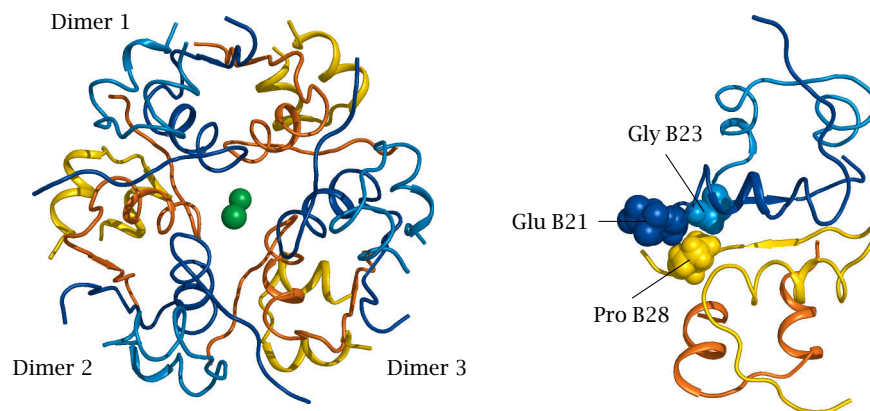

The structure on the left is that of an insulin hexamer, consisting of three dimers. In each dimer, one monomer is shown in yellow and the other in blue; the green balls in the center are zinc ions. On the right, it is shown how the hydrophobic proline residue in position B28 of one monomer interacts favorably with the adjacent side chains of the second monomer; this interaction stabilizes the dimer.

Substitution of proline with a charged residue breaks this favorable interaction. In insulin aspart, the proline is replaced with aspartate, which creates electrostatic repulsion with glutamate B21 on the other subunit. In insulin lispro, proline B28 and lysine B29 are swapped, which also reduces the mutual affinity of the adjoining monomers. Mutants like these are currently widely used in intensive insulin therapy.



14.9 What is the purpose of intensive insulin therapy? What are the tools?

14.5.12 Oral antidiabetic drugs

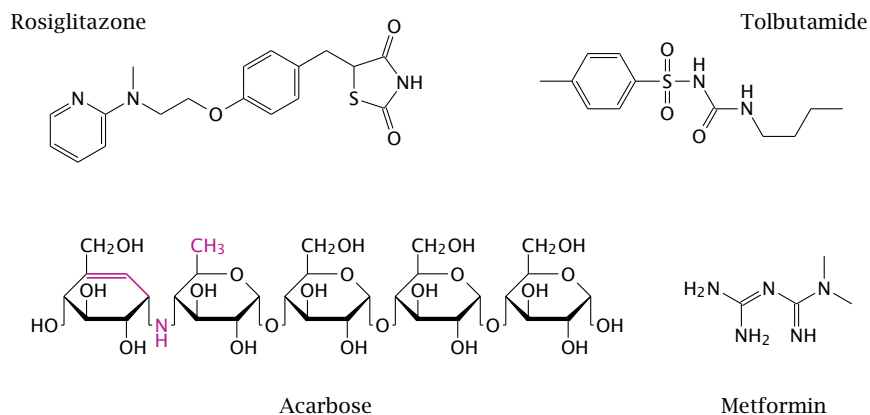

Notes: Oral antidiabetic drugs are used only in type 2 diabetes. These structures are just for illustration—no points for memorizing them.

14.5.13 Action modes of oral antidiabetics

Drug	Action mechanism
tolbutamide	sulfonylurea receptor agonist
rosiglitazone	peroxisome proliferator-activated receptor γ agonist
acarbose	inhibition of the brush border enzymes sucrase and maltase—reduced or delayed glucose uptake
tolrestat	aldose reductase inhibitor (withdrawn)
metformin	NADH dehydrogenase inhibition ?

Notes: The action mode of tolbutamide was covered earlier (slide 13.2.8). Since its role is to stimulate insulin secretion from pancreatic β -cells, it is clear that it is useless in type 1 diabetes, since most or all β -cells are destroyed in this case.

Rosiglitazone is an agonist of the PPAR γ , a nuclear hormone receptor that regulates the transcription of numerous enzymes and transporters involved in glucose and fat metabolism. It reduces insulin resistance in type 2 diabetes, but it has numerous side effects including the promotion of heart failure that have led to its withdrawal from the market in Europe. Efforts to find similar drugs with fewer side effects are ongoing.

Aldose reductase inhibitors have been considered briefly above (slide 14.5.7), and metformin will be considered below.

14.5.14 Hypothetical mode of action of metformin

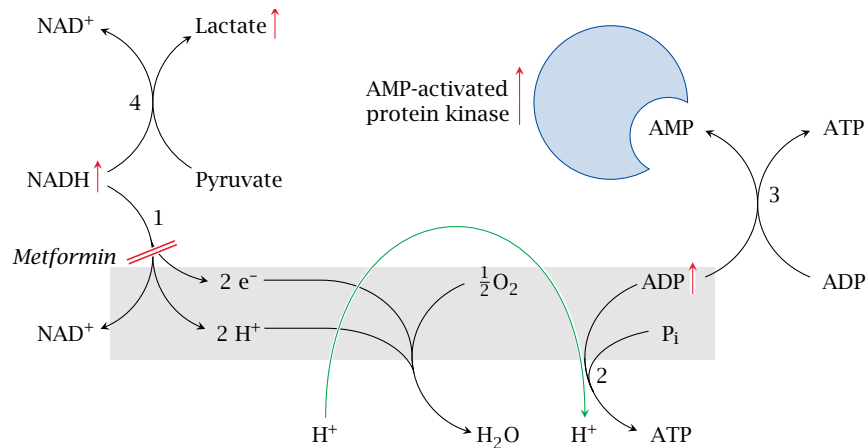

Notes: Metformin and related biguanide drugs are probably the most widely used oral antidiabetics. In vitro, metformin has been shown to inhibit NADH dehydrogenase (1), that is, complex I of the respiratory chain. As a consequence, the activity of ATP synthase (2) should drop, too. This would increase the level of ADP, and adenylate kinase (3) should cause AMP to rise as well.

The regulatory effects of AMP resemble some of those brought about by insulin (slides 7.5.3f). In addition, there is an AMP-activated protein kinase that participates in metabolic regulation. Among other effects, this regulatory enzyme activates insulin-independent glucose uptake by cells that normally do require insulin. Another potentially relevant effect of AMP is the inhibition of adenylate cyclase [84], which would counteract the effect of glucagon and epinephrine, and so help to restore the balance between insulin and its antagonists.

If this proposed mechanism is correct, metformin should also cause accumulation of NADH. This would drive lactate dehydrogenase (4) into reverse mode, producing lactate. Lactate acidosis is indeed a known complication of metformin therapy.

14.5.15 Inhibition of complex I of the respiratory chain by metformin

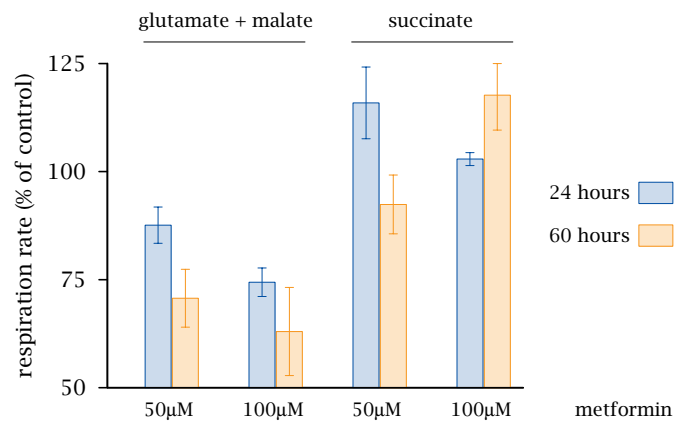

Notes: This slide (data from [85]) shows some experiments supporting the mechanism depicted in the preceding slide. Metformin inhibits the respiratory activity of mitochondria when fed with malate but not when fed with succinate. Malate dehydrogenase produces NADH, which delivers electrons to complex I. In contrast, succinate dehydrogenase produces FADH_2 , which feeds its electrons to complex II and so bypasses the blockade of complex I.

Various aspects of the action mode presented here have been called into question by several experimental studies. One such study attempted but failed to observe the expected concomitant change in the $[\text{ADP}]/[\text{ATP}]$ ratio [86]. Furthermore, genetic knockout of AMP-activated kinase does not abolish the glucose-lowering action of metformin [87]. Therefore, despite the long-standing clinical use of biguanide drugs, their mode of action is not yet fully understood.



14.10 What is the mode of action metformin?

14.6 Answers to practice questions

14.1: In diabetes, insulin is missing (type 1) or ineffective (type 2). Insulin-antagonistic hormones prevail and increase the level of cAMP, which results in decreased fructose-

2,6-bisphosphate due to phosphorylation of the bifunctional enzyme phosphofructokinase 2/fructose-2,6-bisphosphatase. This, in turn, increases the activity of fructose-1,6-bisphosphatase and decreases the activity of phosphofructokinase.

The lack of insulin also induces fat and muscle protein breakdown, which produces glycerol and free amino acids, respectively. Glycerol and most amino acids are substrate precursors for gluconeogenesis.

14.2: In response to the lack of glucose inside the muscle cell, protein degradation is activated. Amino acids are in part completely degraded within the muscle cell, and in part are passed to the liver via the blood stream. Nitrogen that results from amino acid degradation inside the muscle cells is exported from the cell as glutamine or as alanine. To the extent that alanine and other glucogenic amino acids feed into gluconeogenesis in the liver, the carbon cannot re-enter the muscle cell, which accelerates the net loss of carbon from the muscle.

14.3: Acidosis is the acidic deviation of blood pH (<7.35). Acidosis in untreated diabetics is caused by the accumulation of ketone bodies (acetoacetate and β -hydroxybutyrate) in the blood. Acidosis due to ketone bodies is also referred to as *ketoacidosis*.

14.4: Acetone is formed through decarboxylation from acetoacetate, and it might contribute to diabetic coma through its general anesthetic effect.

14.5: Coxsackievirus.

14.6: 1. Dehydration (=loss of water), 2. acidosis, 3. electrolyte imbalances, 4. lack of insulin.

14.7: Hexamers or larger aggregates of insulin are too large to diffuse across from the interstitial fluid into the capillaries. Therefore, the systemic uptake of insulin from aggregated forms is limited by the rate of their dissociation.

14.8: Short term complications: 1. Relapse of hyperglycemia due to inadequate insulin supply or activity, with glucose accumulation and excretion, dehydration and ketoacidosis
2. Hypoglycemia due to excessive application of insulin, which can result in coma

Long term complications: 1. Cataract, through accumulation of sorbitol in the lens
2. Accelerated atherosclerosis and diffuse tissue damage, possibly due in part to glycosylation of proteins.

14.9: Diabetic long term complications are more severe and develop more rapidly in patients whose glucose levels exceed the physiological range. The purpose of intensive insulin therapy is to prevent long term complications by keeping the glucose concentration strictly within the physiological range at all times.

The therapy is based on the frequent measurement of blood glucose, and on the use of highly soluble insulins that upon injection are rapidly taken up into the circulation. An alternative is the use of insulin pumps, which provide an automatic feedback between blood glucose and the insulin infusion rate.

14.10: Metformin is believed to inhibit complex I of the respiratory chain. This would increase the level of AMP in the cell and therefore promote glycolysis and inhibit gluconeogenesis. It would also increase NADH, which in turn would promote the accumulation of lactic acid, which is a known complication of metformin treatment.

Chapter 15

Biosynthetic pathways using tetrahydrofolate and vitamin B₁₂

15.1 Overview

The transfer of single carbon units, in various redox states, is important in several biosynthetic pathways. The two coenzymes tetrahydrofolate and methylcobalamin play central roles in these reactions. Both coenzymes are derived from vitamins, and deficiencies of these vitamins are not uncommonly encountered in clinical medicine, usually as a consequence of another underlying medical condition.

We will first look at the biochemical reaction cycles and then consider the pathological consequences that result from their disruption through vitamin deficiencies.

15.2 Tetrahydrofolate-mediated carbon transfer reactions

15.2.1 The role of tetrahydrofolate in biosynthetic reactions

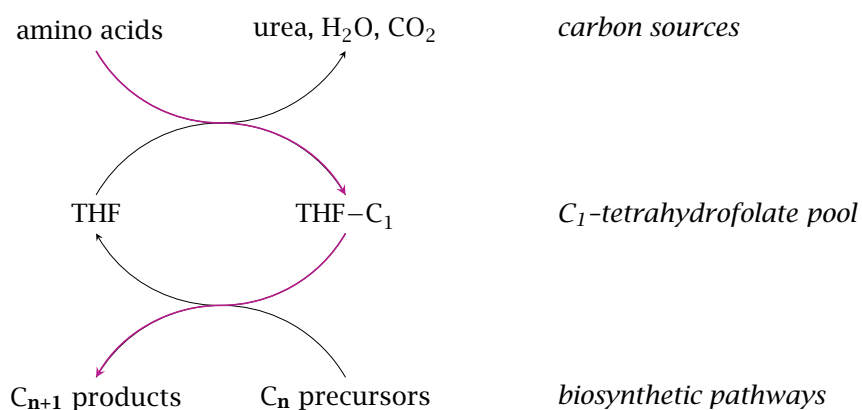

Notes: The degradation pathways for several amino acids produce single carbon units that are transferred to tetrahydrofolate (THF) as an intermediate carrier.

Tetrahydrofolate, in turn, donates the single carbons to various biosynthetic intermediates.

15.2.2 Folic acid is reduced by dihydrofolate reductase (DHFR)

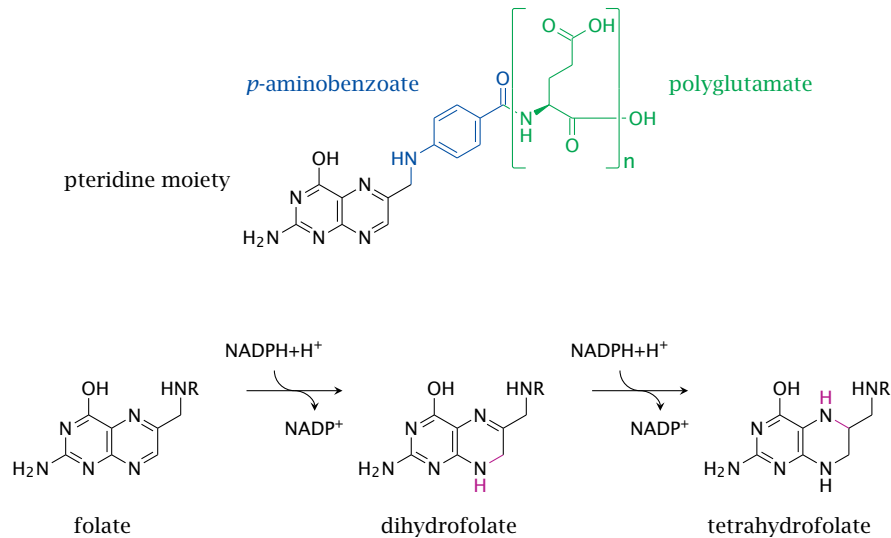

Notes: Folic acid is the vitamin as it is found in the diet. It consists of three distinct moieties: a pteridine moiety, a *p*-aminobenzoate moiety, and one or several glutamate residues.

The metabolically active form is tetrahydrofolate, which is formed from folate in two successive NADPH-dependent reductions, both catalyzed by the same enzyme, namely, dihydrofolate reductase.

The number of glutamate residues contained in folic acid or tetrahydrofolate (THF) changes at various stages of transport and utilization. Intestinal uptake and transport through the blood occur with only one glutamate attached. After uptake into liver cells, several more glutamate residues are added. The number of glutamate residues present is involved in the regulation of folate-dependent metabolism.

15.2.3 Sources and destinations of C₁ units transferred by tetrahydrofolic acid

Sources:

1. *serine, glycine*
2. *histidine, tryptophan*

Biosynthetic destinations:

1. *purine bases*
2. *thymine*
3. *S*-adenosylmethionine → *choline phospholipids, creatine, epinephrine, DNA methylation*

Notes: Degradation of the amino acids glycine, serine, histidine and tryptophan provides C₁ units to tetrahydrofolate. Serine and glycine are more abundant than the two others and therefore are the main sources.



15.1 Summarize the role of tetrahydrofolic acid in metabolism.

15.2.4 The serine hydroxymethyltransferase reaction: release of CH₂O

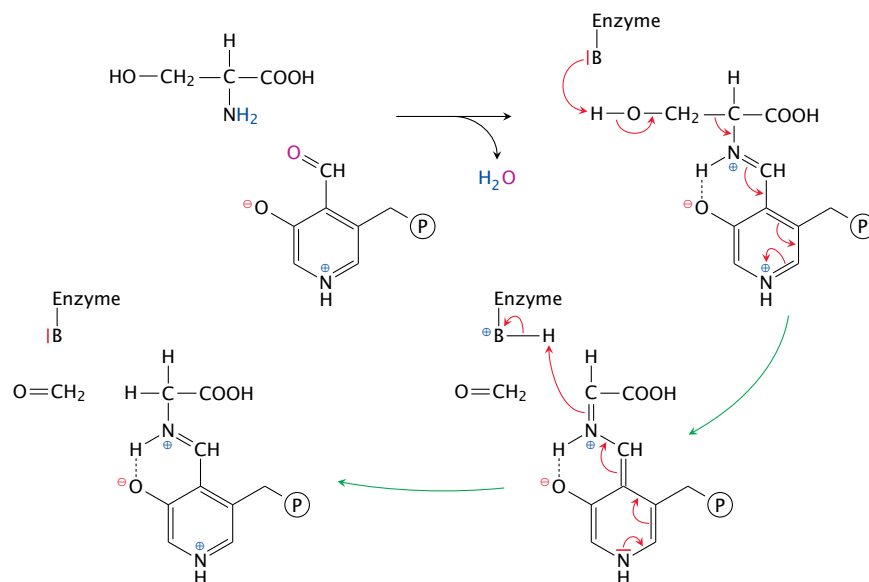

Notes: One of the major reactions that supply C₁ units to THF is the cleavage of serine by serine hydroxymethyltransferase. The active site of this enzyme contains the coenzyme pyridoxal phosphate (PLP) and a catalytic base (here represented by B). As in amino acid transamination (section 12.2), the α -amino group of the substrate serine forms a Schiff base with PLP. Through this bond, PLP can reversibly withdraw and donate electrons, which in cooperation with the catalytic base facilitates cleavage of the bond between the α - and the β -carbon. The β -carbon is released as formaldehyde, and the aldimine is subsequently hydrolysed to release glycine (not shown).

Note that the reaction is reversible and therefore can bring about the synthesis of serine from glycine and *N,N'*-methylene-THF.

15.2.5 The serine hydroxymethyltransferase reaction (2): capture of formaldehyde by THF yields *N,N'*-methylene-THF

Notes: The formaldehyde released by serine cleavage is captured immediately by THF while still within the active site. This yields *N,N'*-methylene-THF.

It should be noted that, while the mechanism presented here is found in the textbooks, an alternate mechanism has been proposed in which THF plays a more immediate role in the cleavage of serine, and free formaldehyde does not occur as an intermediate [88].

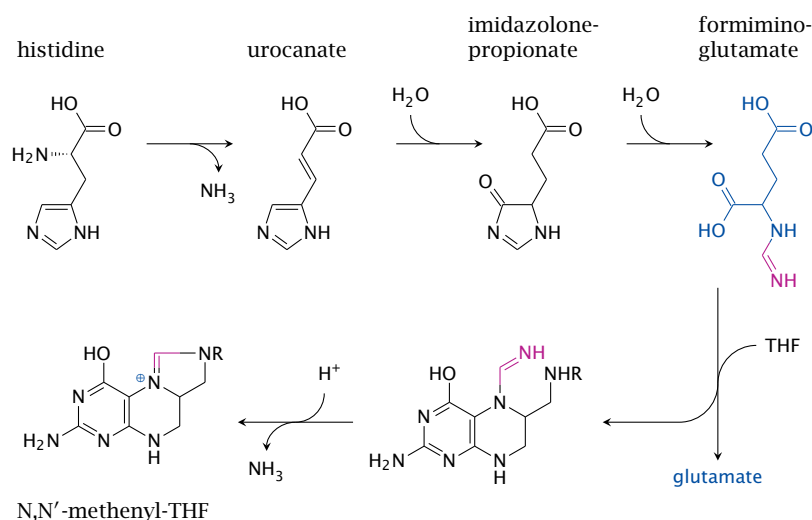
15.2.7 Histidine degradation produces *N,N'*-methenyl-THF

Notes: Degradation of histidine proceeds via the intermediates urocanate, imidazolone-propionate and formimino-glutamate. The formimine (or methenimine) group of the latter is transferred to tetrahydrofolate. Subsequent cleavage of ammonia yields *N,N'*-methenyl-THF, which can either be oxidized to formyl-THF or reduced to *N,N'*-methylene-tetrahydrofolate (see slide 15.2.8).

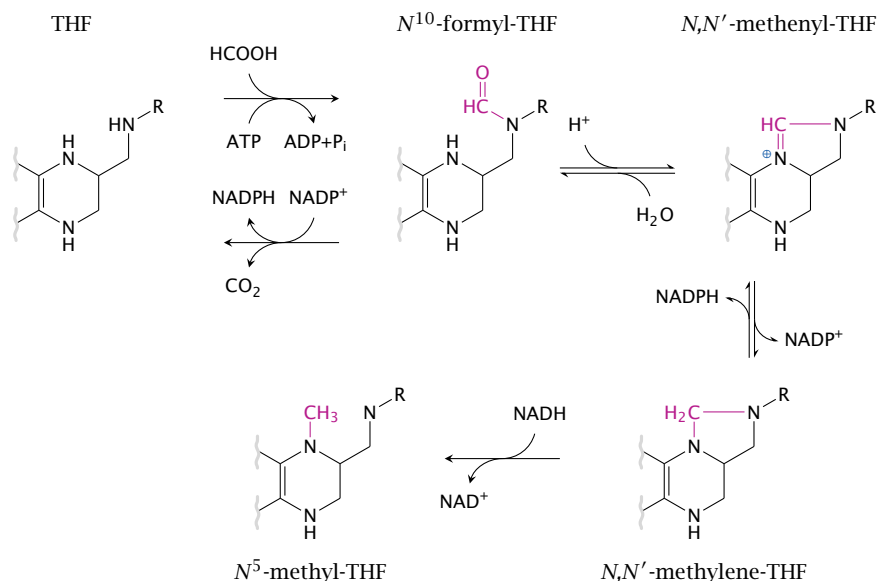
15.2.8 Redox transitions between various forms of C₁-THF

Notes: C₁ derivatives of THF exist in different redox states that can be converted into one another. The final reduction, which leads from *N,N'*-methylene-tetrahydrofolate to *N*⁵-methyl-THF, is apparently irreversible; this is relevant for the methyl trap hypothesis that accounts for the pathogenesis of anemia in vitamin B₁₂ deficiency (see slide 15.5.6).

*N*¹⁰-Formyl-THF can be formed from THF through capture of formic acid, which in turn arises from tryptophan degradation. It can also be converted back to THF by NADP⁺-dependent dehydrogenation of the formyl group to CO₂. The latter reaction is used to dispose of excess C₁-intermediates when supply exceeds demand.

15.2.9 Overview of flux through the C₁-THF pool

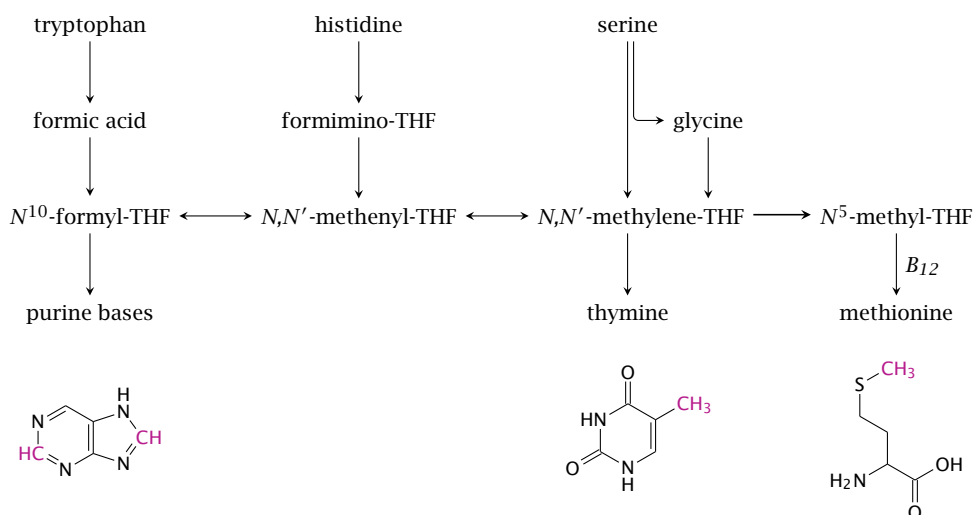

Notes: Formyl-THF and *N,N'*-methylene-THF donate carbons in nucleotide synthesis. Methyl-THF donates methyl groups to the synthesis of methionine. Methionine synthesis constitutes the link between folate-dependent and vitamin B₁₂-dependent C₁ metabolism. An activated form of methionine functions as a methyl donor in several important biosynthetic pathways (see slide 15.4.2).

In the depicted structures of adenine, thymine and methionine, the carbons that are acquired via THF are highlighted.



15.4 What are the possible redox states of C₁ carbon associated with tetrahydrofolate? Which ones supply the synthesis of purine bases, of thymine, and of methionine, respectively?

15.3 Folate antimetabolites as antimicrobials

Notes: Folic acid metabolism in microbes contains drug targets for antimicrobial therapy. An important example are the sulfonamides, which became available in the 1930s and were the first broad-spectrum antibacterial drugs. The first such drug, sulfamidochrysoidine (trade name Prontosil), was developed as a red dyestuff. Its antibacterial activity was discovered in a test program that systematically evaluated the effects of all the company's new compounds in animal experiments.

The compound as such, when tested *in vitro*, has no antibacterial activity. The active component is sulfanilamide, which is released in animals or humans

by reductive metabolism. Its antibacterial action is due to its competition with *p*-aminobenzoic acid, which is a precursor that becomes incorporated into folic acid in its bacterial biosynthesis (see slide 15.2.2). Since humans do not synthesize folate, they are not affected by sulfanilamide.

Sulfamidochrysoidine (Prontosil)

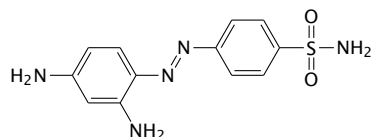

Pyrimethamine

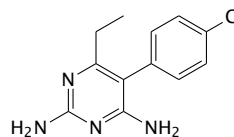

Sulfanilamide

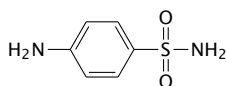

Trimethoprim

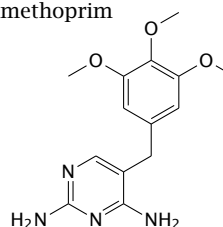
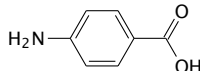
*p*-Aminobenzoic acid

The antibacterial effect of sulfonamides can be substantially increased by combination with inhibitors of dihydrofolate reductase such as trimethoprim. In this case, the selective toxicity of the inhibitor for bacteria is due not to the absence of the enzyme in humans—dihydrofolate reductase is needed in both bacterial and human metabolism—but instead to the molecular differences between the bacterial and the human enzyme.

Combinations of a sulfonamide and a dihydrofolate reductase inhibitor can also be used in the treatment of some *protozoal* infections. One such combination, sulfadoxine plus pyrimethamine, was widely used against malaria at one time, but the development of resistance among the malaria parasites has since made it obsolete in this application. It is still used in toxoplasmosis and *Pneumocystis carinii* infections.

Inhibitors of human dihydrofolate reductase, such as methotrexate, are used in the treatment of tumors and autoimmune diseases (see slide 16.9.5).



15.5 Explain the therapeutic applications of inhibitors of folic acid synthesis and of dihydrofolate reductase.

15.4 Cobalamin-dependent methylation reactions

15.4.1 Structure of methylcobalamin

Notes: Cobalamin is a coenzyme with a complex structure. Its corrin ring coordinates a single cobalt ion, which is central to the ability of cobalamin to facilitate the cleavage and formation of carbon bonds by way of radical intermediates.

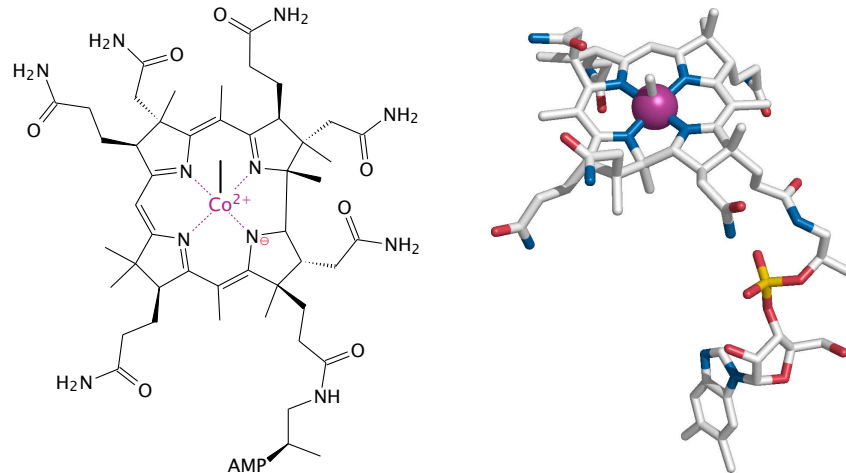

The two major forms of cobalamin are adenosylcobalamin and methylcobalamin. Shown here is methylcobalamin, which is formed as an intermediate in the synthesis of methionine from homocysteine (see below). The methyl group is obtained from *N*⁵-methyl-THF. In this chapter, we only deal with methylcobalamin-dependent reactions. Adenosylcobalamin is needed in the utilization of propionyl-CoA (see slide 10.3.6); it is not considered in detail in these notes.

15.4.2 The *S*-adenosylmethionine (SAM) cycle requires vitamin B₁₂

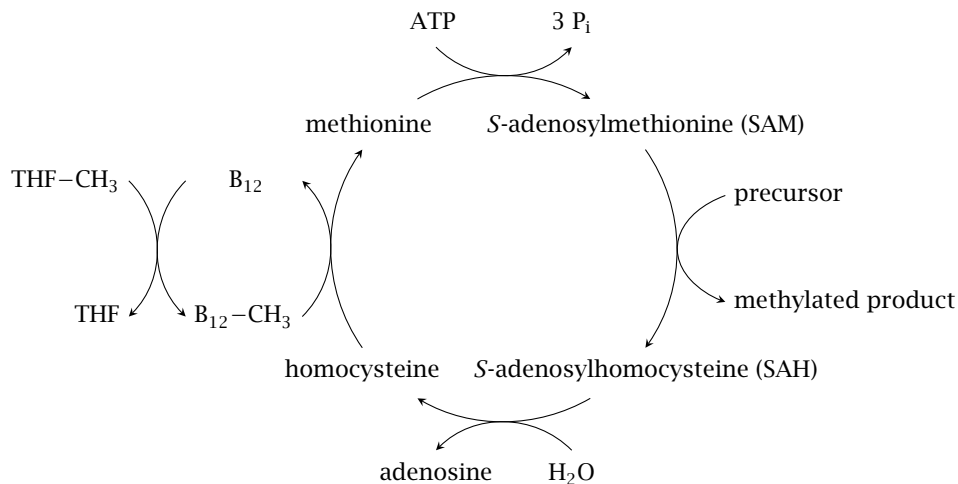

Notes: In the SAM cycle, methionine is first activated to *S*-adenosylmethionine (SAM), which then serves as a methyl group donor in various biosynthetic reactions. Methyl group donation leaves behind *S*-adenosylhomocysteine, which is then cleaved to adenosine and homocysteine. The regeneration of methionine from homocysteine requires vitamin B₁₂ in the form of methylcobalamin.

15.4.3 Structures of S-adenosylmethionine and S-adenosylhomocysteine

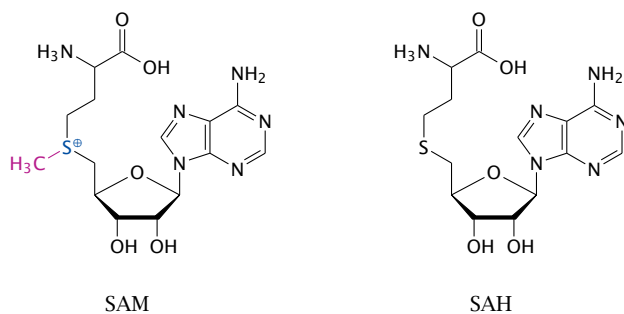

Notes: The key feature of SAM is the methyl group attached to a sulfonium ion (S^+). The inherent instability of the sulfonium group makes this compound a good methyl group donor.

S-adenosylhomocysteine (SAH) is not only the byproduct of SAM-dependent methylation reactions but also a competitive inhibitor. It must therefore be recycled promptly in order to avoid disruption of the SAM cycle. In vitamin B_{12} deficiency, the regeneration of SAM from SAH is impeded, and the accumulating SAH interferes with subsequent methylation reactions [89].

15.4.4 SAM-dependent methylation reactions

1. methylation of phosphatidylethanolamine (PE) to phosphatidylcholine (PC)
2. guanidinoacetate \rightarrow creatine
3. norepinephrine \rightarrow epinephrine
4. acetylserotonin \rightarrow melatonin
5. DNA methylation
6. methylation of drugs (e.g. mercaptopurine)

Notes: Among these pathways, the biosynthesis of PC and of creatine are quantitatively the most important ones.

 **15.6** What biosynthetic reactions require vitamin B_{12} ?

15.4.5 Phosphatidylethanolamine methylation

Notes: Phosphatidylcholine (PC) is a major constituent of mammalian cell membranes. It is formed in three successive SAM-dependent methylation steps from phosphatidylethanolamine (PE).

PC can also be synthesized using dietary choline, and conceivably this pathway might supply enough PC for myelin synthesis. However, in animal experiments, depletion of vitamin B_{12} has been shown to decrease PC and to increase PE in the brain [90], suggesting that PE methylation is important for sufficient PC synthesis.

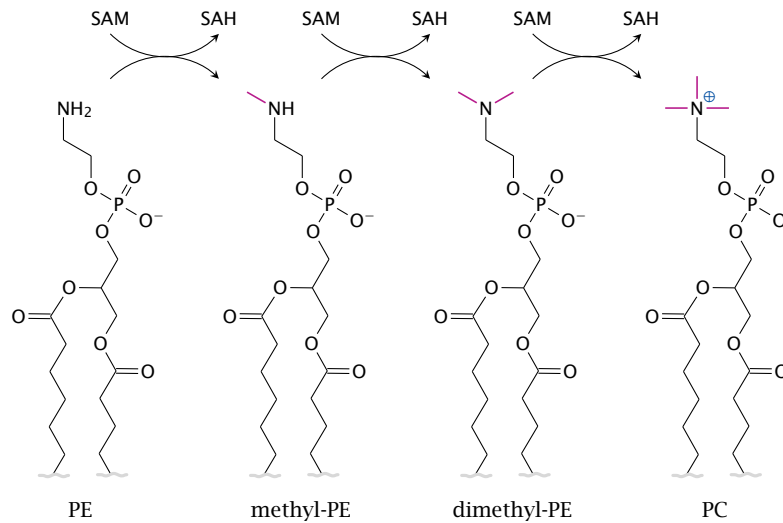

15.4.6 Sphingomyelin acquires its phosphocholine headgroup from PC

Notes: Sphingomyelin, another important membrane phospholipid, is synthesized from its precursor ceramide through phosphocholine transfer from PC; therefore, its synthesis indirectly also depends on the SAM cycle and vitamin B₁₂.

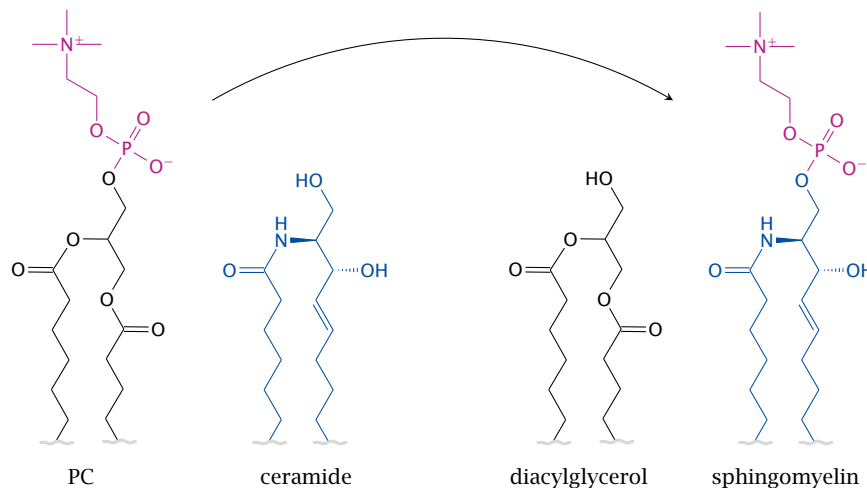

15.7 What is the SAM cycle? At what point in the cycle is vitamin B₁₂ required?

15.4.7 Major nerve fibers are myelinated

Notes: Myelin sheaths consist of multiple layers of cell membranes, which contain more phospholipids and less protein than most other cell membranes. These elaborate structures enable the *saltatory conduction* of action potentials, which is much faster than the pedestrian non-saltatory conduction that occurs along non-myelinated fibers. The picture shows a cross section through a single nerve

fiber; the thick, dark zone surrounding the axon is the myelin, which consists of multiple stacked membrane bilayers.¹

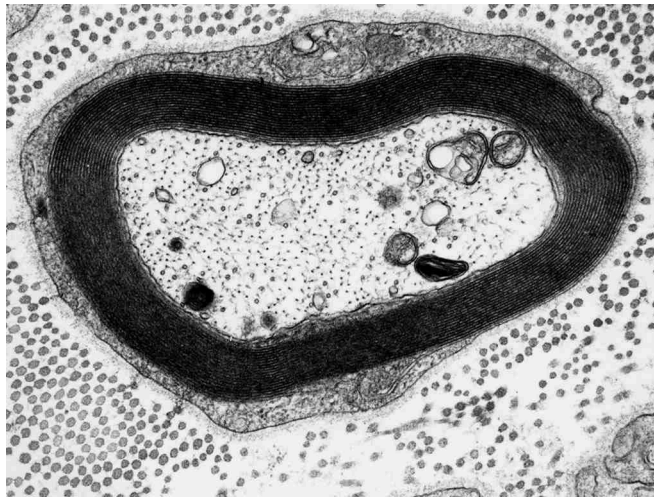

Cobalamin deficiency causes demyelination of nerve fibers in the central and peripheral nervous system. The neurological, and in advanced stages neuropsychiatric, consequences can be severe. In addition to the disruption of PC and sphingomyelin biosynthesis, deficient methylation of myelin-associated proteins has been considered as another pathogenic mechanism [89].

15.4.8 Creatine metabolism

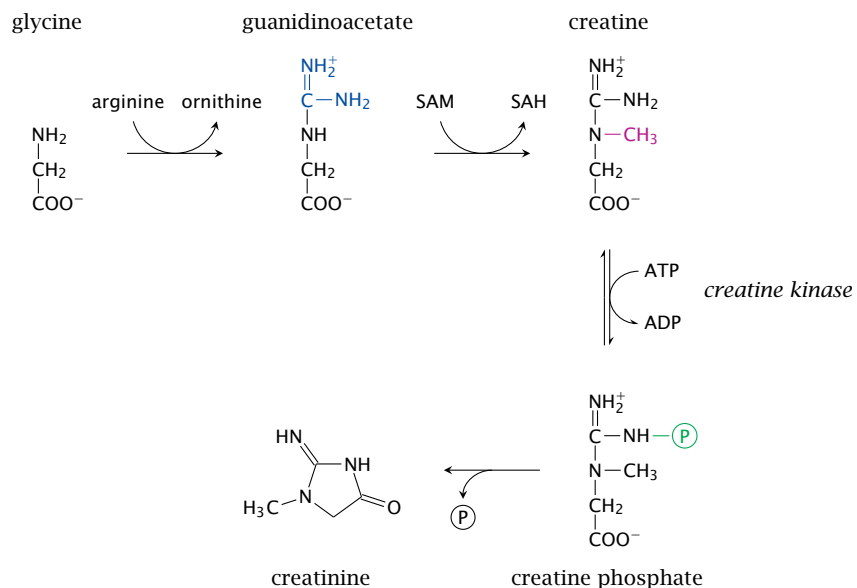

Notes: The first two steps in creatine synthesis occur in the kidney and the liver, respectively; the second step involves S-adenosylmethionine. Most of the creatine

¹The number of stacked bilayers surrounding the axon in this picture is approximately 20, but it can be substantially higher in the fastest-conducting axons.

is then accumulated in skeletal muscle. There, it is reversibly phosphorylated to creatine phosphate. This reaction is readily reversible, and the physiological function of creatine phosphate is to form a rapidly available reserve of energy-rich phosphate groups.

Heart and skeletal muscle contain different isoforms of creatine kinase (CK). As with other enzymes, an increased activity of CK in the plasma is a diagnostic indicator of organ damage. High levels of the cardiac isoform of CK are a typical sign of a recent myocardial infarction or of viral myocarditis.

As indicated in the slide, creatine phosphate can undergo spontaneous ring closure to creatine; this reaction affects approximately 1.5% of the total creatinine pool every day. Creatine is eliminated through the kidneys, predominantly through glomerular filtration. Its concentration in the plasma is used as a diagnostic indicator of kidney function—the lower the glomerular filtration rate, the higher the steady-state concentration of creatinine. In elderly patients, the creatinine level is often used to adjust the dosages of drugs that also undergo renal elimination.

15.5 Folate and vitamin B₁₂ deficiency syndromes

Since both folate and B₁₂ are vitamins, deficiency arises from disruptions of intestinal uptake. We therefore need to understand how this intestinal uptake occurs.

15.5.1 Uptake, transport and storage of folic acid

- contained in vegetables (Latin *folium* = leaf)
- synthesized by bacterial flora in the large intestine
- active transport mediates intestinal uptake and renal reuptake, as well as accumulation in the liver
- 50% of all folate is stored in the liver

Notes: The high folate content of the liver is consistent with its prominent role in amino acid metabolism.

Since nutrients and vitamins are typically taken up from the small intestine, one might wonder whether or not folate that is synthesized by bacteria in the colon can be taken up by the host. Experiments with instillation of isotopically labeled folate during colonoscopy indicate that uptake from the large intestine is indeed possible [91]. However, the depletion of folate observed in malnutrition or in diseases of the small intestine indicates that colon bacteria do not provide folate in sufficient amounts.

15.5.2 Causes of folate deficiency

- inflammatory bowel diseases
- surgical bowel resection (short intestine syndrome)

- cytochrome P450-inducing drugs
- excessive alcohol consumption—contentious

Notes: The first two causes in this list compromise the resorption of folic acid from the small intestine; they apply similarly to many other nutrient deficiency syndromes as well. Alcohol is often cited as a cause of folate deficiency, but no single biochemical mechanism has emerged as the major connection: “Ethanol-associated folate deficiency can develop because of dietary inadequacy, intestinal malabsorption, altered hepatobiliary metabolism, enhanced colonic [that is, bacterial] metabolism, and increased renal excretion” [92].

In studies on the effects of alcohol on folate metabolism with experimental animals, the poor—or lucky, some might say—fellers were usually exposed to excessive dosages, as for example in [93]. In several studies on humans, the correlation between alcohol intake and folate deficiency has been altogether questioned; see for example [94].

Several members of the cytochrome P450 family of enzymes are important in the degradation and inactivation of drugs, which, like folate-dependent metabolism, occurs to a large extent in the liver (see chapter 18). Due to their broad substrate specificities, they cause some modification and inactivation of innocent bystander metabolites also; one of these is folic acid. Various drugs, including ethanol, increase cytochrome P450 activity through transcriptional induction, and long-standing application of such drugs may cause depletion of folic acid through increased metabolism.

15.5.3 Folate deficiency causes macrocytic anemia

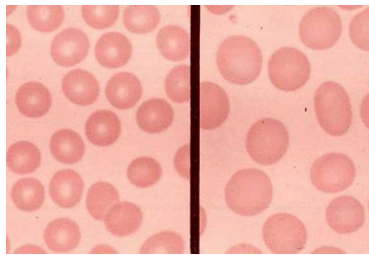

normal red cells macrocytic red cells

Notes: In macrocytic anemia, the number of blood cells is reduced, but the size of the individual cells is increased. With red blood cells, the content of hemoglobin per cell is also increased. On the whole, however, the hemoglobin content of the blood is decreased, which makes this condition a form of *anemia*.

C₁ units derived from THF are required at several points in nucleotide biosynthesis (see slide 15.2.9). The inhibition of nucleotide biosynthesis that results from the lack of THF will interfere with DNA synthesis and cell division more strongly than with protein synthesis. Protein synthesis “outruns” DNA synthesis, leading to the accumulation of more protein per cell between successive cell divisions. In the precursor cells of erythrocytes, this causes a greater than normal hemoglobin content per cell.

Macrocytosis—enlargement of red blood cells—is also often observed in alcoholism, but it may not always be caused by folate deficiency, and the overall content of hemoglobin in the blood may not be reduced.

15.5.4 The intestinal uptake of vitamin B₁₂ involves multiple carrier proteins

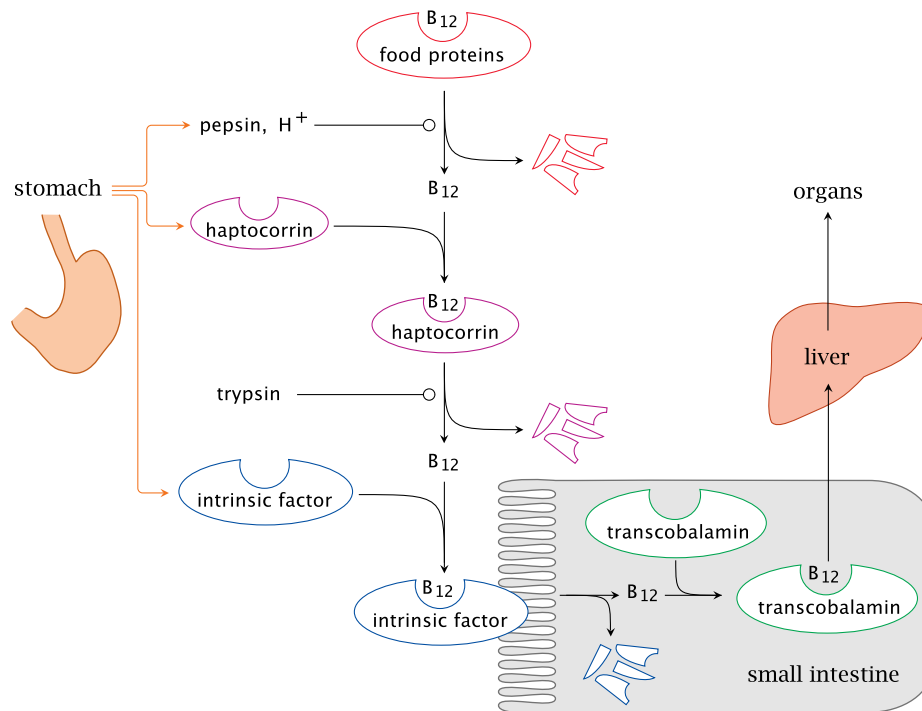

Notes: The intestinal uptake of vitamin B₁₂ is a rather intricate affair. The vitamin contained in the food is bound to enzymes or other proteins. In the stomach, these are denatured by gastric acid and cleaved by pepsin. The vitamin thus released is immediately bound by the carrier protein haptocorrin, which is secreted by the gastric mucous membrane.

When the stomach contents reach the small intestine, haptocorrin itself is degraded by trypsin or other pancreatic proteases, and vitamin B₁₂ is released again. The free vitamin is then recaptured by *intrinsic factor*, a second carrier protein that is also produced by the gastric mucosa (and which up to this point simply came along for the ride). The B₁₂-intrinsic factor complex then travels all the way down to the terminal ileum, the lowermost section of the small intestine, where it is taken up by receptor-mediated endocytosis. Inside the cells of the gut epithelium, vitamin B₁₂ changes carriers for a third time; bound to its final carrier, transcobalamin, the vitamin then reaches the liver and all other tissues beyond.

The daily uptake of vitamin B₁₂ is on the order of only 1-5 μg. The liver stores about 2-5 mg. When uptake is disrupted, this store will last a long while before vitamin deficiency becomes clinically manifest.

15.5.5 Various causes of B₁₂ deficiency

Disease	Pathogenetic mechanism
autoimmune gastritis	destruction of the gastric parietal cells that produce gastric acid, haptocorrin, and intrinsic factor
pancreatic insufficiency	failure to digest haptocorrin
inflammatory bowel disease	disrupted uptake of B ₁₂ bound to intrinsic factor
receptor deficiencies	disrupted binding and cellular uptake of intrinsic factor or transcobalamin

Notes: Uptake can be disrupted in various circumstances. Crohn's disease, a major form of inflammatory bowel disease, often most severely affects the terminal ileum, which is where cobalamin, bound to intrinsic factor, must be taken up. In many Crohn's patients, the terminal ileum is damaged to a point where it needs to be surgically removed.

The classical form of vitamin B₁₂ deficiency, known as *pernicious anemia*, is caused by an autoimmune disease that destroys the *parietal cells*, the specific cell type in the gastric mucosa that secretes both haptocorrin and intrinsic factor. The parietal cells also produce gastric acid, the lack of which will compromise the release of B₁₂ from food proteins.

The earliest clinical treatment of pernicious anemia due to vitamin B₁₂ deficiency consisted in the ingestion of copious amounts of homogenized raw liver. Apparently, this was not everybody's cup of tea, and some patients refused this treatment, in spite of the serious consequences. The situation improved when liver extracts enriched for the vitamin became available. Nowadays, the pure compound is applied orally or intravenously.

As stated above, the amount of cobalamin stored in the liver is many times larger than the daily requirement; the vitamin deficiency therefore tends to become clinically manifest with considerable delay after the disruption of vitamin uptake. This is something to watch out for in patients who have apparently recovered from some intestinal disease or surgery but who have been left with compromised digestive or absorptive function.

Cobalamin has a very high affinity for cyanide, and cyanocobalamin is a common synthetic derivative used as a supplement. Hydroxycobalamin can shed a hydroxide and bind a cyanide ion. In gram amounts, hydroxycobalamin can be used to scavenge free cyanide in acute cyanide poisonings; reportedly, this treatment is superior to the use of oxidative agents that induce the formation of methemoglobin as a cyanide scavenger [95].

15.5.6 Disruption of folate-dependent metabolism by vitamin B₁₂ deficiency: the methyl trap hypothesis

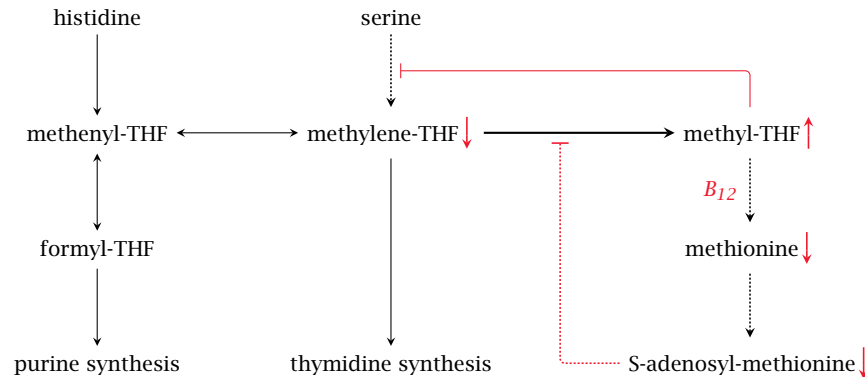

Notes: Like folic acid deficiency, a lack of vitamin B₁₂ causes macrocytic anemia, and the changes to the cells found in the peripheral blood and in the bone marrow are indistinguishable between the two conditions. In folate deficiency, the macrocytosis can be explained by the inhibition of nucleotide synthesis (see slide 15.5.3). However, unlike folic acid, cobalamin itself is not required for those synthetic pathways (see slide 15.2.9). How, then, can we account for the clinical resemblance? This is explained by the methyl trap hypothesis.²

When vitamin B₁₂ is deficient, S-adenosylmethionine (SAM) will be lacking (see slide 15.4.2). SAM imposes feedback inhibition on the reduction of *N,N'*-methylene tetrahydrofolate to methyl-THF; therefore, the lack of SAM permits excessive accumulation of methyl-THF. The high level of methyl-THF, in turn, inhibits serine hydroxymethyltransferase, which is one of the major reactions that supply C₁ units to the THF pool (see slide 15.2.4). The C₁-THF pool becomes depleted. In keeping with this explanation, folate substitution does transiently improve the blood count in patients with B₁₂ deficiency.

A lacking capacity for biosynthetic methylation also interferes with the synthesis of phospholipids, which in turn causes demyelination of nerve fibers (see section 15.4). The neurological consequences tend to be more grave in vitamin B₁₂ deficiency than in folate deficiency.



15.8 Explain why vitamin B₁₂ deficiency causes macrocytic anemia.

15.6 Answers to practice questions

15.1: Tetrahydrofolate is formed from the vitamin folic acid through reduction by the enzyme dihydrofolate reductase. THF acquires C₁ subunits from the degradation of amino acids, in particular serine and glycine, and donates them in biosynthetic reactions such as thymidylate synthase, purine synthesis, and the synthesis of S-adenosylmethionine.

15.2: Serine + tetrahydrofolate → glycine + *N,N'*-methylene tetrahydrofolate + H₂O

²Some theoretical principles seem to be forever stuck with the byword “hypothesis,” such as the current one or the “Mary Lyon hypothesis” (see slide 9.4). Both hypotheses are actually well supported by observation; see [96] for experimental evidence supporting the methyl trap hypothesis.

15.3: The glycine cleavage system is a multi-enzyme complex that consists of three different enzymes and a substrate carrier protein with a lipoamide moiety. It cleaves glycine according to the following equation:

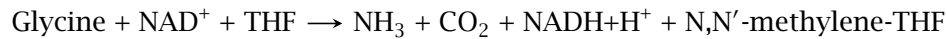

15.4: The C₁ carbon can be carried by THF as a formyl, methenyl, methylene, or methyl group. Purine synthesis uses formyl-THF, thymidylate synthase uses methylene-THF, and methionine synthesis uses methyl-THF.

15.5: Folic acid is synthesized by microbes but not by human cells. Therefore, inhibitors of folate synthesis are selectively toxic for microbes and can be used for antimicrobial therapy. Sulfonamides are the predominant class of folate synthesis inhibitors.

Dihydrofolate reductase occurs in both microbial and human cells. Inhibitors that selectively target the microbial enzymes are available and are used for antimicrobial therapy, preferably in conjunction with sulfonamides. Inhibitors of the human enzyme are used in cancer therapy and for immunosuppression.

15.6: See slide 15.4.4.

15.7: The *S*-adenosylmethionine or SAM cycle is a pathway that mediates the transfer of methyl groups from *N,N'*-methyl-THF to phosphatidylethanolamine (PE) and various other substrates. The first reaction, which is vitamin B₁₂-dependent, is the transfer of the methyl group from methyl-THF to homocysteine, which yields methionine. Using ATP, methionine is then activated to *S*-adenosylmethionine, which donates the methyl group to various acceptors, including PE, epinephrine, and (cytosine bases in) DNA. The cleavage of *S*-adenosylhomocysteine to adenosine and homocysteine completes the cycle.

15.8: In vitamin B₁₂ deficiency, macrocytic anemia arises through the formation of excessive amounts of methyl-tetrahydrofolate, at the expense of formyl- and methylene-THF, which are required in the synthesis of nucleotides.

Vitamin B₁₂ is required in the conversion of homocysteine to methionine, which is then converted to *S*-adenosylmethionine. The latter exerts feedback inhibition on the reduction of methylene-THF to methyl-THF. Lack of vitamin B₁₂ disrupts this negative feedback.

Chapter 16

Nucleotide metabolism

16.1 Introduction

16.1.1 Functions of nucleotides in biochemistry

- Building blocks of nucleic acids
- Cosubstrates and coenzymes
- Signaling

Notes: I'll be wildly optimistic and assume that you remember a thing or two about nucleic acids, so we will mostly skip this topic.

Nucleotides are very important as cosubstrates in metabolism. As you know, ATP occurs everywhere, but GTP, CTP, and UTP drive some biochemical reactions as well.

Adenosine and adenine nucleotides also function as signaling molecules; for example, ADP is important in thrombocyte activation. Caffeine is an antagonist at adenosine receptors, which tells us that adenosine is important in the regulation of vigilance. Cyclic AMP (slide 7.5.4) and cyclic GMP (slide 9.3.6) function as intracellular second messengers.

16.1.2 Structures of NAD, acetyl-CoA, and PAPS

Notes: Nucleotides also occur as parts of more complex cosubstrates and coenzymes, three of which are shown here. These three molecules have very different "business ends." In coenzyme A, the business end is the thiol group that becomes bound to the substrate, and in NAD⁺ it is the nicotinamide moiety that undergoes reversible reduction and oxidation. In 3'-phosphoadenosine-5'-phosphosulfate (PAPS), the key feature is the mixed phosphosulfate anhydride that activates the sulfate toward transfer, in much the same way as the terminal phosphate is

activated in ATP. In methylcobalamin, the chemically active center is the cobalt ion that facilitates carbon bond cleavage and formation (see section 15.4).

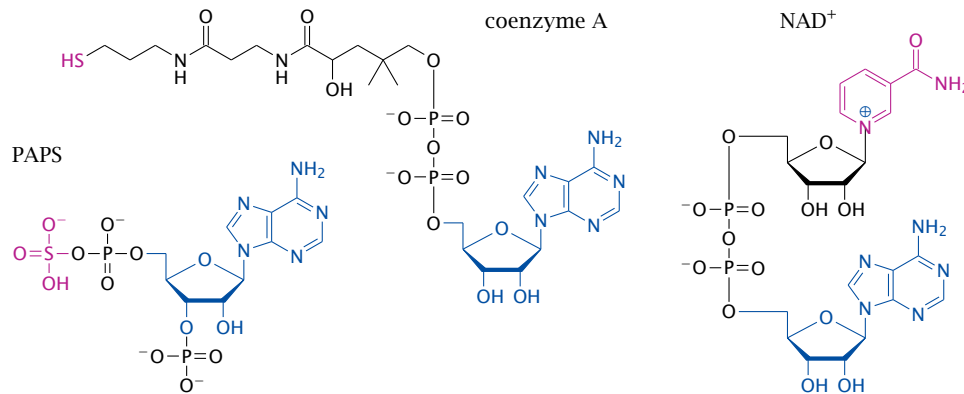

The adenosine moiety found in each of these molecules, shown in blue, does not directly participate in any of the catalytic functions; instead, it just serves as a tag to facilitate recognition of the cosubstrates by the corresponding enzymes. Why, then, do cosubstrates so often possess nucleotides as their binding tags, rather than for example amino acids or peptides? A plausible answer is provided by the RNA world hypothesis.

16.1.3 The RNA world hypothesis

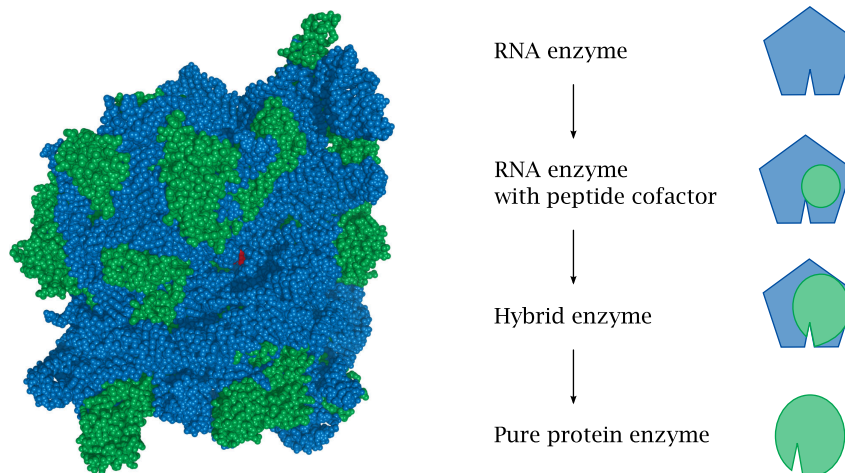

Notes: The RNA world is a hypothetical early stage of evolution. In this early world, RNA was the predominant macromolecule. RNA not only stored and propagated genetic information, a role that is almost universally filled by DNA in current life forms, but it also realized and expressed this information, which in current life forms is mostly accomplished by proteins.

The empirical basis of the RNA world hypothesis is that RNA can indeed assume the role of DNA, as it still does in RNA viruses and viroids, and that it can also have catalytic activity, as is the case in ribosomes and smaller ribozymes.

The structure of the ribosome also suggests an evolutionary path along which RNA enzymes may have been replaced by protein enzymes in evolution. The catalytic centers of a ribosome (left) consist entirely of RNA (blue). The tiny red dot in the center represents the antibiotic chloramphenicol, lodged in one of the active sites of a bacterial ribosome; we are peeping at it through the ribosome's peptide exit tunnel. Ribosomal proteins (green) serve in structural and auxiliary roles.

Like ribosomes, other RNA enzymes may at first have coopted peptides as structural components, and possibly as coenzymes. The peptides may then have grown into ever more important roles within the hybrid molecules, until they took over entirely and made the RNA component obsolete.

16.1.4 Why have cosubstrates become fossilized, whereas enzymes have not?

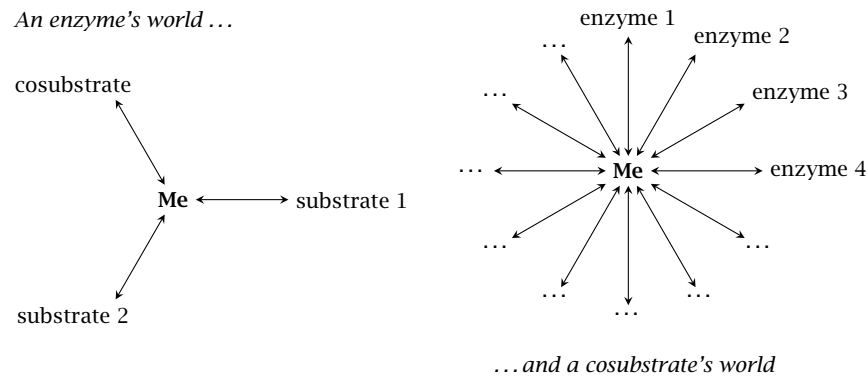

Notes: In a world dominated by RNA, one would expect cosubstrates and carrier molecules to contain some nucleotide moieties also. However, if the above scenario for the evolutionary replacement of RNA enzymes by protein enzymes is correct, why did a similar replacement not occur with cosubstrates?

Let us consider the world from the perspective of an enzyme and of a cosubstrate, respectively. An enzyme's world is simple, containing one or a few substrates and maybe a cosubstrate or coenzyme. If we make some random change to the structure of the enzyme, there is a reasonable chance that the interactions with all of these ligands will remain intact.

In contrast, a cosubstrate such as ATP or NADH inhabits a much more complex world, containing a very large number of interacting enzymes. Chances are that a change to its molecular structure would disrupt its interaction with some enzyme molecule or other that is essential to the survival of the cell. Structural changes to cosubstrates are therefore "forbidden," and they may well look now exactly as they did shortly after life first arose billions of years ago.¹

¹The acyl carrier protein (ACP) domain that is found in fatty acid synthase is basically coenzyme A with adenosine replaced by a peptide moiety (see slide 10.5.3). This is possible since ACP is private property of fatty acid synthase and does not need to function with other enzymes.

The constraining effect of a large number of interactions can also be seen with peptides like glutathione or proteins like calmodulin, which are also very strongly conserved throughout evolution.



16.1 Explain the RNA world hypothesis, and the concept that nucleotide-based coenzymes may be molecular fossils from the RNA world.

16.2 Overview of metabolic pathways for nucleotides

16.2.1 Metabolic routes and pathways of nucleotides

- *De novo* synthesis
- Intestinal uptake of nucleosides
- Endogenous turnover (partial degradation/salvage)
- Degradation and excretion

Notes: Synthesis of nucleotides from scratch occurs in all tissues, and its capacity is sufficient to fully cover the needs of the organism; we do not require any nucleotides or bases in the diet. Nevertheless, nucleic acids contained in the diet are broken down to nucleosides, which are taken up with high efficiency and degraded (see section 16.4).

The pathways for the degradation of endogenous nucleotides have some overlap with those for dietary ones. Intermediates of nucleotide degradation can also enter salvage pathways and then be reverted to complete nucleotides. We will now look at all these pathways in turn.

There are two major synthetic pathways, for purine and pyrimidine bases, respectively, both of which diverge towards their ends to produce the different variants. We will begin with the pathway for purine synthesis.

16.3 Purine synthesis

16.3.1 Overview of purine synthesis

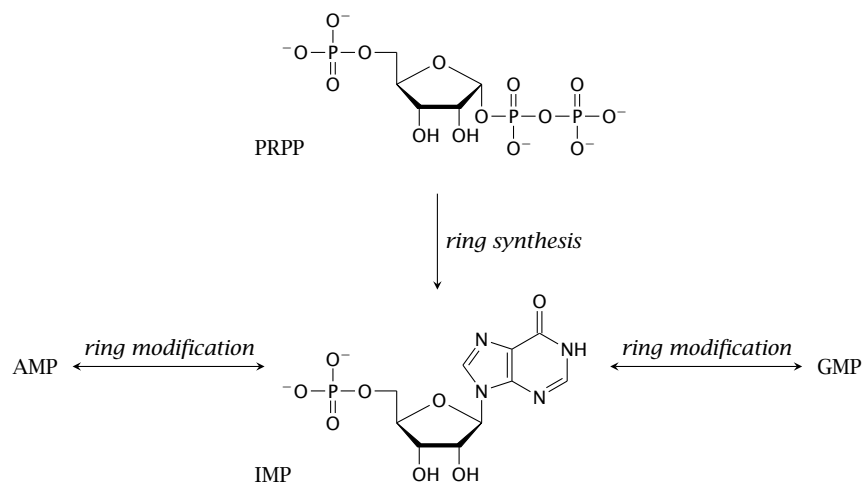

Notes: Adenine and guanine nucleotides are derived from a common precursor, inosine monophosphate (IMP), which consists of ribose phosphate and a purine

derivative known as hypoxanthine. IMP is synthesized from 5'-phosphoribosyl-1'-pyrophosphate (PRPP) in a sequence of no less than 10 steps. In two of these steps, single carbon units are acquired from N^{10} -formyltetrahydrofolate.

The conversions of IMP to AMP and to GMP, respectively, are reversible. Therefore, AMP and GMP can be converted into one another via IMP as required.

16.3.2 IMP synthesis (1)

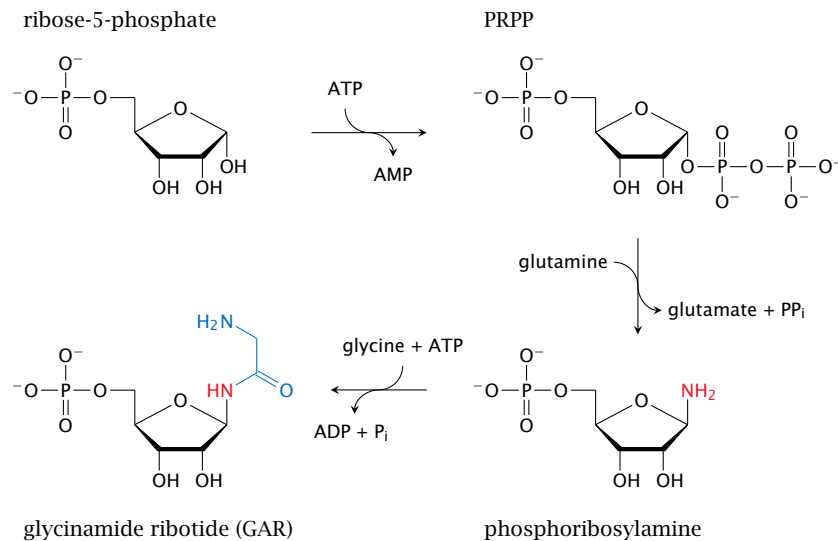

Notes: The substrate of the first reaction, ribose-5-phosphate, is supplied by the hexose monophosphate shunt. The enzymes for the reactions shown in this slide are, in order, ribose phosphate diphosphokinase, glutamine-PRPP-amidotransferase, and glycinamide ribotide synthetase.

16.3.3 IMP synthesis (2)

Notes: Construction of the hypoxanthine ring continues in a piecemeal fashion; atoms highlighted in different colors are derived from different precursors. Products (enzymes): FGAR, formylglycinamide ribotide (GAR transformylase); FGAM, formylglycinamide ribotide (FGAM synthetase); AIR, 5'-aminoimidazole ribotide (AIR synthetase); CAIR, 4'-carboxy-5'-aminoimidazole ribotide (AIR carboxylase); SAICAR, succinyl-aminoimidazole-carboxamido-ribose (SAICAR synthetase); AICAR, aminoimidazole-carboxamido-ribose (adenylosuccinate lyase).

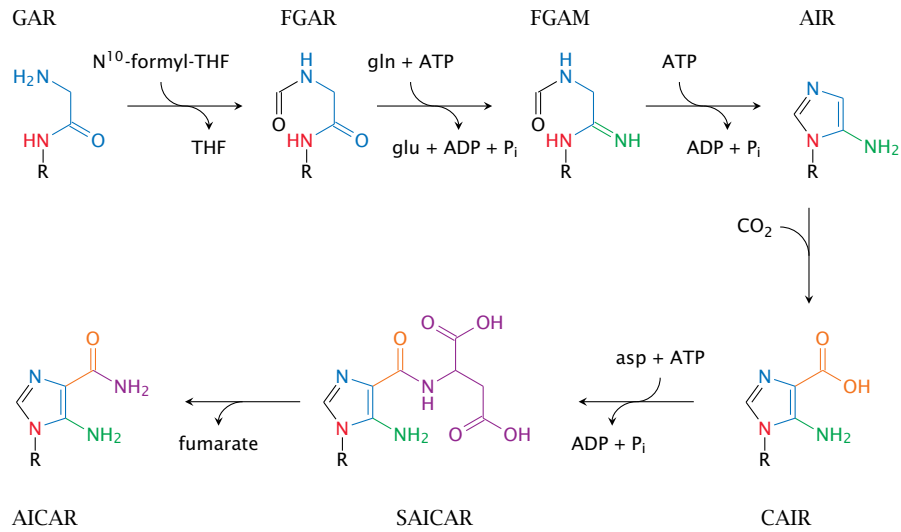

16.3.4 IMP synthesis (3)

Notes: AICAR transformylase and IMP cyclohydrolase conclude the synthesis of the ribose-attached hypoxanthine ring.

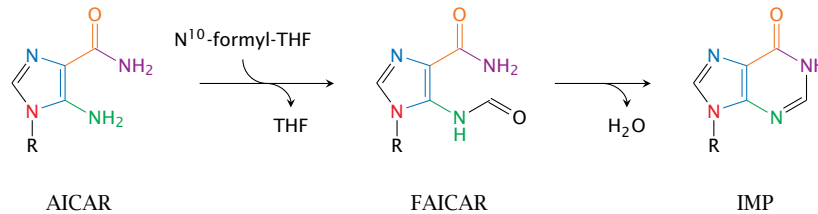

Most of the chemistry in this pathway seems quite straightforward. Where ATP or GTP come into play, they are used to phosphorylate hydroxyl groups, which are thus activated for substitution by ammonia (released from glutamine) or by the amino group of aspartate.

The most remarkable reaction appears to be the direct carboxylation of 5-aminoimidazole ribotide (AIR) by AIR carboxylase, which unlike e.g. pyruvate carboxylase requires neither ATP nor biotin. Indeed, AIR carboxylase uses CO₂ directly instead of ATP-activated bicarbonate, which is used by the biotin-dependent enzymes. This is made possible by its energetic coupling with the subsequent reaction (see next slide).

16.3.5 A bifunctional enzyme combines AIR carboxylase and SAICAR synthetase activities

Notes: AIR carboxylase is actually part of a bifunctional enzyme that also contains the next enzyme activity in the pathway (SAICAR synthetase), and the carboxylated product (CAIR) is directly channeled to the SAICAR synthetase active site. The

two active sites are located close to the entrance and the exit, respectively, of a connecting tunnel [97].

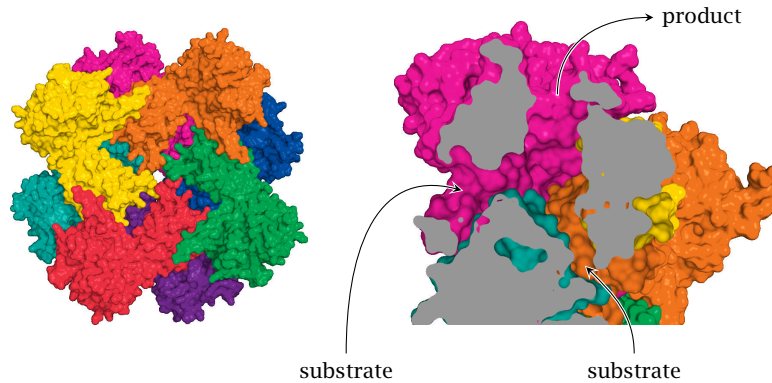

The equilibrium of the AIR carboxylase reaction probably does not favor the product (CAIR). In contrast, the SAICAR synthetase is driven forward by ATP hydrolysis. Thus, the tunnel that connects the two active sites would seem to function like a “vacuum cleaner” that removes all the product from the AIR carboxylate site and thereby pushes that reaction forward also. Structure rendered from [2h31.pdb](#).

16.3.6 Synthesis of AMP from IMP

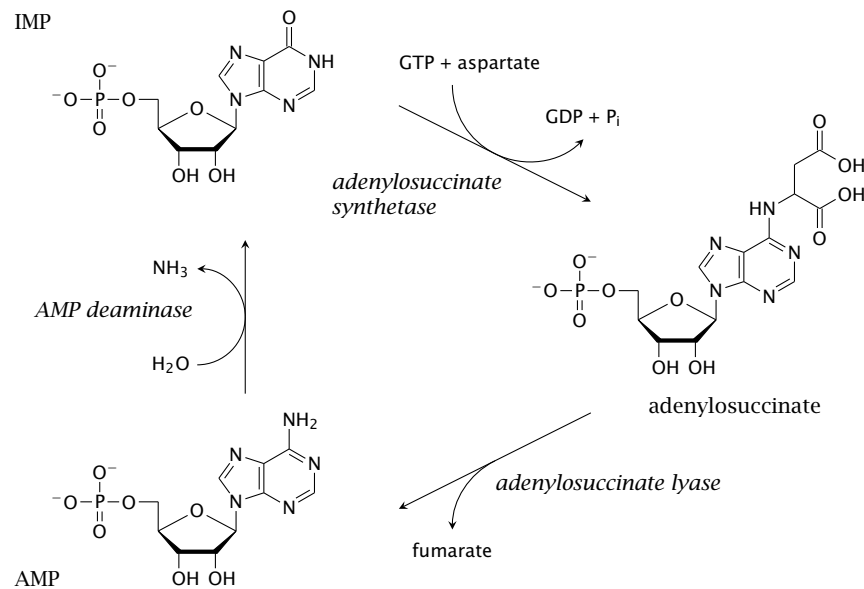

Notes: The synthesis of AMP from IMP occurs in two steps. In the first step, an aspartate is acquired to form adenylosuccinate. The subsequent elimination of fumarate—or, strictly speaking, the elimination of AMP *from* fumarate—is similar to the conversion of SAICAR to AICAR (slide 16.3.3). Indeed, both reactions are carried out by the same enzyme, which is named adenylosuccinate lyase after the reaction depicted here.

If the supply of AMP exceeds demand, it can be converted back to IMP by AMP deaminase, either for degradation or for conversion to GMP (see slide 16.3.7). Taken together, the three reactions in this slide create a cycle that does not accomplish any net turnover of AMP but simply splits aspartate to fumarate, with the hydrolysis of GTP. This so-called *purine nucleotide cycle* may indeed be activated in muscle tissue, where it serves to swiftly increase the pool of TCA cycle intermediates in times of increased energy demand. However, it seems that a genetic deficiency for adenine deaminase is quite common and usually asymptomatic [98], suggesting that the function of this cycle is not crucial for muscle function.

16.3.7 Synthesis of GMP from IMP

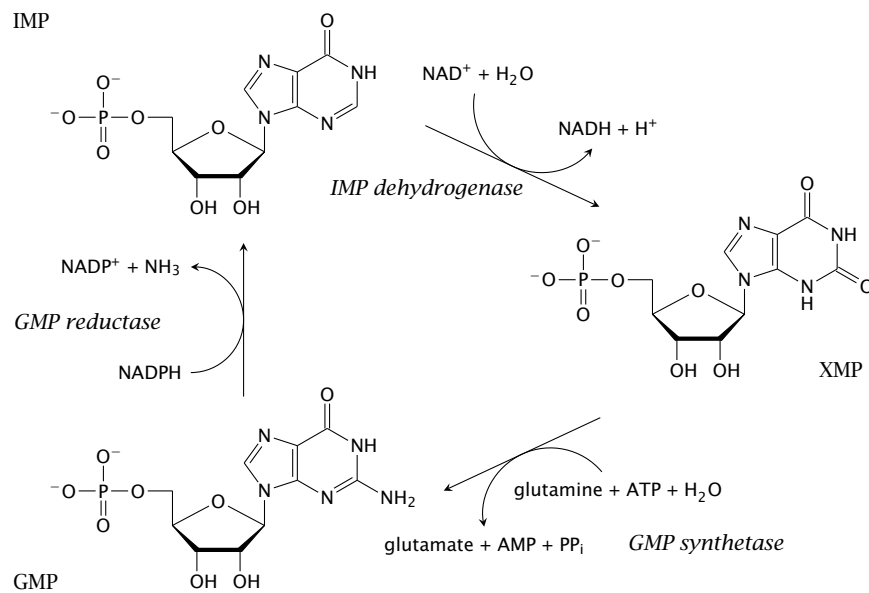

Notes: After the initial dehydrogenation of IMP to xanthosine monophosphate (XMP), glutamine serves once more as the nitrogen donor in the conversion of this intermediate to GMP. Excess GMP can be turned back into IMP for degradation or conversion to AMP.

Note the crosswise utilization of cosubstrates in the syntheses of AMP and GMP: AMP synthesis requires GTP, whereas GMP synthesis is driven by ATP. Therefore, an oversupply of either purine nucleotide will accelerate the synthesis of the other one. This arrangement helps to adjust the abundance of the two purine bases according to metabolic demands. Additional mechanisms that help to ensure this balance are discussed in the next slide.

16.3.8 Feedback regulation in purine synthesis

Notes: Purine synthesis is subject to feedback inhibition at several levels. All guanine and adenine nucleotides allosterically inhibit the synthesis of phosphoribosylamine (PRA) from PRPP. The common precursor IMP inhibits the formation

of PRPP itself, as do ADP and GDP (not shown). These effects adjust the flow through the common pathway up to IMP in keeping with the total need for purine nucleotide synthesis.

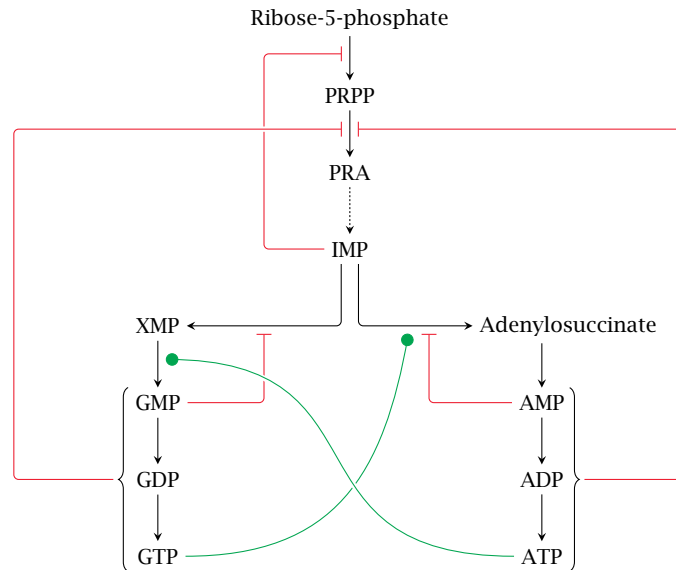

The balance between AMP and GMP synthesis is maintained by the crosswise cosubstrate requirement that was discussed above (green lines). In addition, GMP and AMP both inhibit the formation of their immediate precursors from IMP; this inhibition is competitive.



16.2 Give an overview of the biosynthesis of purine nucleotides and its regulation.

16.4 Utilization of dietary nucleic acids

16.4.1 Overview of digestion and utilization of nucleic acids

Notes: Nucleic acids are of nutritive value mainly because of the sugars they contain, namely, ribose and deoxyribose. In the small intestine, pancreatic nucleases (DNase and RNase) break down nucleic acids to nucleotides, which are dephosphorylated by alkaline phosphatase to nucleosides; the latter are taken up by sodium-coupled active transport. There are two intestinal transporters that prefer purine and pyrimidine nucleosides, respectively, but have fairly broad and overlapping specificity. This loose specificity permits piggyback uptake of nucleoside analogue drugs such as idoxuridine and 6-mercaptopurine riboside (see section 16.9).

After uptake, nucleosides mostly undergo degradation in the liver. Cleavage by purine and pyrimidine nucleoside phosphorylases gives free bases and ribose- or deoxyribose-1-phosphate. The sugar phosphates are converted to mainstream degradative intermediates via short adapter pathways (see next slide).

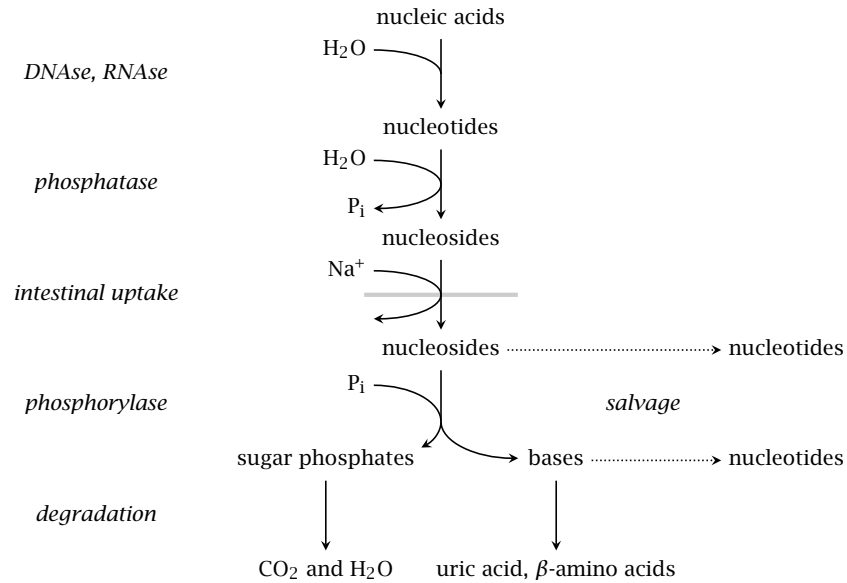

Both free bases and uncleaved nucleosides can in principle be reused toward the synthesis of nucleotides. However, the salvage pathways that accomplish this appear to mostly process endogenously synthesized bases, whereas those obtained from the diet mostly undergo degradation and excretion [99, 100].

16.4.2 Utilization of ribose and deoxyribose

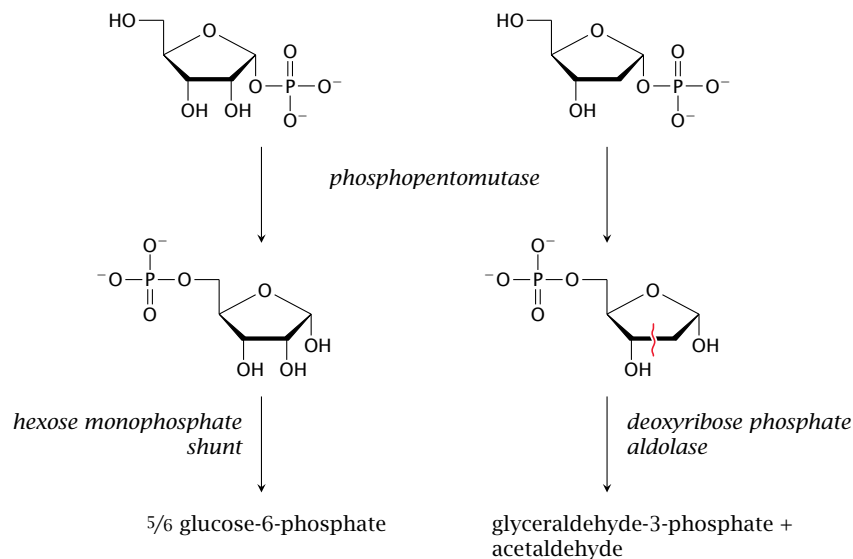

Notes: The ribose-1-phosphate and deoxyribose-1-phosphate that are released from dietary nucleosides are first converted to the respective 5-phosphates by phosphopentomutase. This reaction is analogous to the interconversion of glucose-6-phosphate and glucose-1-phosphate by phosphoglucomutase (see slide 8.3.1).

The subsequent utilization pathways diverge. Ribose-5-phosphate is an intermediate of the hexose monophosphate shunt and can be converted to glucose-6-

phosphate in this pathway (see slide 9.2.2). Deoxyribose-5-phosphate is cleaved—across the red squiggly line in the figure—by a specific aldolase, which produces glyceraldehyde-3-phosphate, an intermediate of glycolysis, and acetaldehyde. The latter is also an intermediate in ethanol degradation (see slide 7.4.2) and is utilized along this pathway.



16.3 Can ribose and deoxyribose be utilized for the synthesis of glucose? If so, do they both provide the same yield of glucose per mole of starting material?

16.5 Purine degradation and salvage pathways

The following pathways account for the degradation of endogenous purine nucleotides, as well as of the free bases that result from the phosphorolysis of dietary ones.

16.5.1 Degradation of endogenous purine nucleotides (overview)

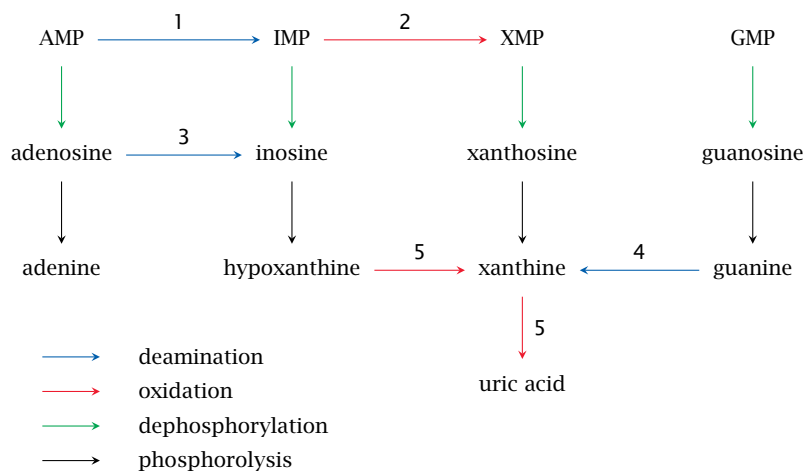

Notes: Enzymes: 1, AMP deaminase; 2, IMP dehydrogenase; 3, adenosine deaminase; 4, guanase; 5, xanthine dehydrogenase or oxidase.

The AMP deaminase reaction is shown in the next slide; the adenosine deaminase reaction is analogous. The guanase and xanthine dehydrogenase/oxidase reactions are depicted in slide 16.5.3. The dephosphorylation of the monophosphate nucleotides to the nucleosides and the subsequent phosphorolysis to free bases occurs in the same way as outlined above for dietary nucleotides and nucleosides (slide 16.4.1).

16.5.2 Adenine nucleotide degradation

Notes: As shown in slide 16.5.1, the degradation of AMP can follow several alternative routes that perform dephosphorylation, phosphorolysis, deamination, and oxidation reactions in different sequences. This figure depicts one of these alternative routes in detail. The depicted reactions are catalyzed by AMP deaminase

(1), IMP dehydrogenase (2), 5'-nucleotidase (3), purine nucleoside phosphorylase (4), and xanthine dehydrogenase/oxidase (5).

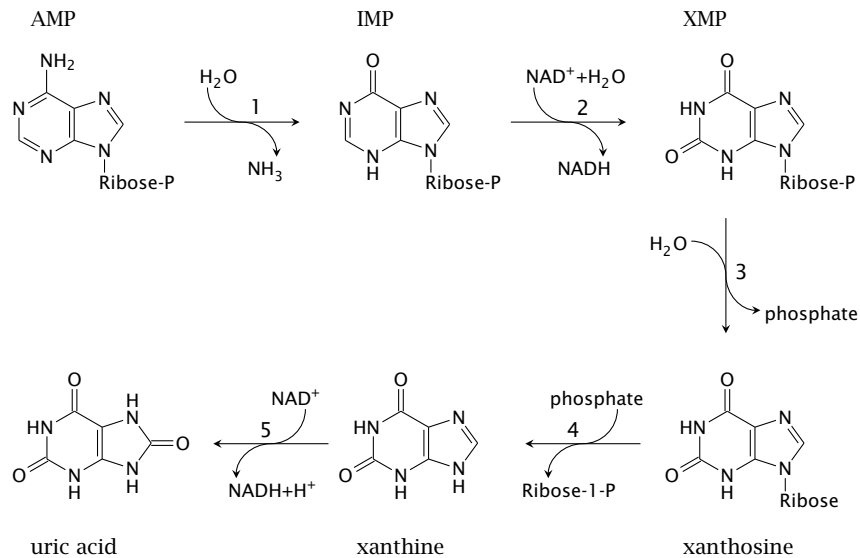

16.5.3 The guanase and xanthine dehydrogenase/oxidase reactions

Notes: Guanase deaminates guanine to xanthine, which is again converted to uric acid by xanthine dehydrogenase. The latter enzyme also occurs in a second variation, which arises through protein modification. Intracellularly, most enzyme molecules function as a dehydrogenase and reduce NAD⁺, as shown in the previous slide. Partial proteolysis, or the introduction of a strategic disulfide bond, prevent the interaction of the enzyme with NAD⁺, and the molecule then switches to O₂ reduction, as shown in this slide. The oxidase activity is found in extracellular enzyme molecules, which lack a supply of NAD⁺ anyway.

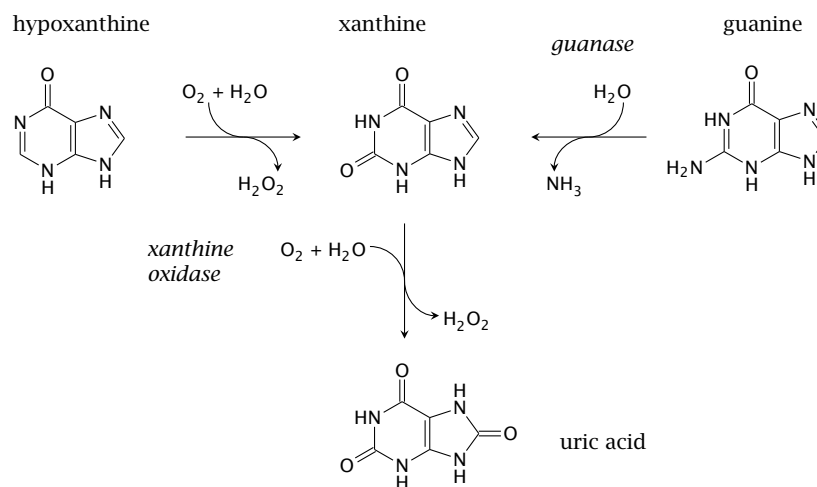

As we had seen before, adenosine degradation may produce free hypoxanthine. Xanthine dehydrogenase or oxidase both can convert hypoxanthine to xanthine and the latter to uric acid.



16.4 Explain the metabolic utilization of dietary nucleic acids.

16.5.4 Renal urate elimination: tubular reuptake and secretion

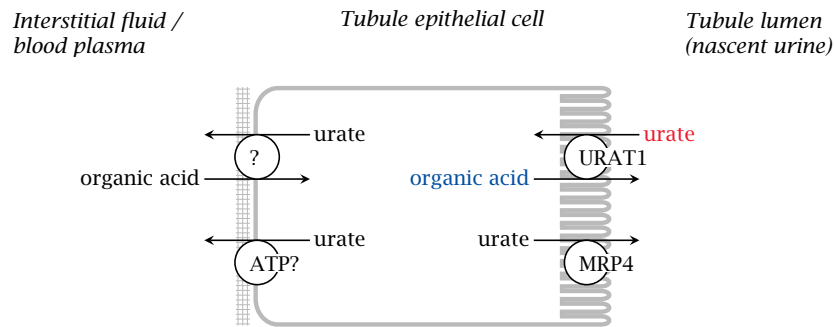

Notes: Most of the uric acid formed by purine degradation is eliminated via the kidneys. Urate is subject primarily to glomerular filtration and tubular reuptake (see slide 14.2.5), while tubular secretion (by an ABC transporter named MRP4) is less important.

Reuptake of urate from the primary filtrate is mediated by the URAT1 exchange transporter. Several drugs and metabolites that affect renal urate elimination interact with this transporter [101]. Typically, when present in the lumen of the tubule, such compounds will compete with urate for reuptake; this is the mode of action of *uricosuric* drugs like benzbromarone or probenecid. On the other hand, when present inside the epithelial cells, they may act as substrates for exchange and therefore increase the rate of reuptake, as is the case with pyrazinoic acid (see slide 16.6.5).

16.5.5 Non-primates break down uric acid to allantoin

Notes: While uric acid is the terminal product of purine degradation in humans and other apes, many other organisms, ranging from fungi to mammals, perform several subsequent reactions that degrade uric acid further to allantoin, which is then excreted. Allantoin is more water-soluble than uric acid and therefore avoids the problems that can arise from the low solubility of uric acid in humans (see slide 16.6.2).

The first step in urate degradation is carried out by urate oxidase (uricase). Interestingly, humans actually possess an inactive copy of the urate oxidase gene, which indicates that at some point during evolution this enzyme activity was lost. Since the genetic enzyme defect spread throughout the entire population, there likely was some selective advantage to it. Several hypotheses have been proposed as to the nature of this advantage, ranging from antioxidant effects of uric acid over protection from UV irradiation to a rise in blood pressure. While

the correlation between uric acid blood levels and hypertension is worth noting from a clinical point of view [102], the biological advantage of an increase in blood pressure is not obvious to me; and even if it existed, it would seem implausible for evolution to cripple a perfectly fine pathway when a plethora of other physiological mechanisms for adjusting the blood pressure was already available.

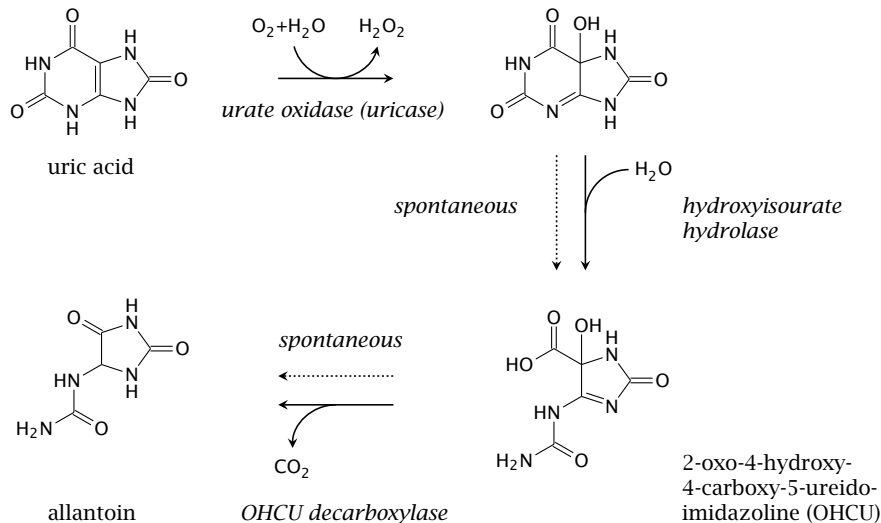

While the role of urate oxidase has been known for a long time, the subsequent two enzyme reactions shown in this slide have only recently been discovered [103]. The reason for their delayed discovery is that urate oxidase alone is sufficient for the conversion of urate to allantoin, since the subsequent reactions also occur spontaneously. The major difference is that the spontaneous decay produces allantoin as a racemic mixture, whereas enzymatic formation gives rise to one enantiomer only.

16.5.6 Overview of purine salvage reactions

Notes: Nucleosides and free bases that arise during the degradation of nucleic acids and nucleotides can be salvaged and reused. This scheme shows the reactions involved in purine salvage, which produce AMP, GMP and IMP. The conversion of the latter to AMP or GMP (blue arrows) involves the same reactions as in *de novo* synthesis (see slides 16.3.6 and 16.3.7).

Enzymes: 1, adenosine kinase; 2, inosine kinase; 3, guanosine kinase; 4, adenine phosphoribosyltransferase (APRT); 5, hypoxanthine-guanine phosphoribosyltransferase (HGPRT). The APRT and HGPRT reactions are analogous to the orotate phosphoribosyltransferase reaction (see slide 16.7.1).

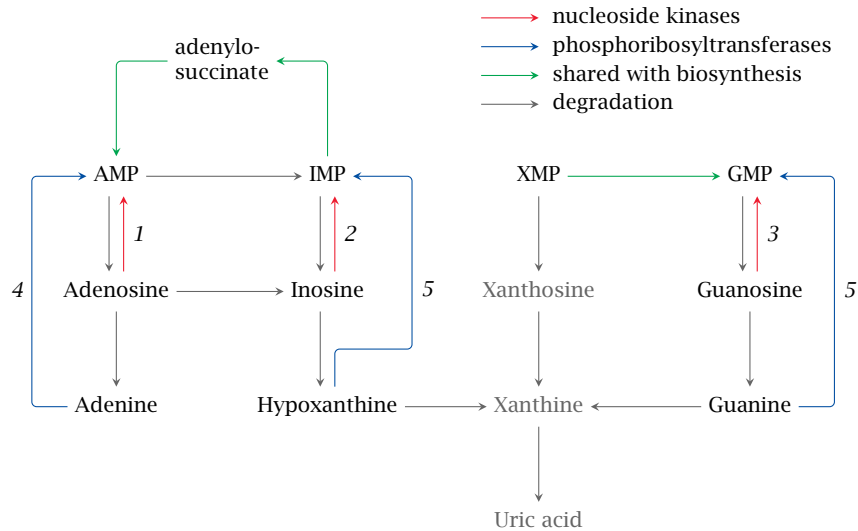

16.6 Diseases related to purine degradation

16.6.1 Enzyme defects in purine degradation and salvage

Notes: Adenosine deaminase deficiency induces apoptosis in T cells, which results in severe combined immunodeficiency (SCID; see section 19.2).

Enzyme	Biochemical effects	Clinical symptoms
adenosine deaminase	accumulation of dA and dATP	severe combined immunodeficiency (SCID)
HGPRT	defective purine salvage, increased <i>de novo</i> synthesis and degradation	gout; impeded cerebral development and self-mutilation (Lesch-Nyhan syndrome)

HGPRT is encoded on the X chromosome; therefore, the enzyme defect, which is known as Lesch-Nyhan syndrome, is observed mostly in boys. Excessive urate production and gout are expected, but the causation of the neurological symptoms is not well understood. Excessive activation of adenosine receptors in the brain during fetal development has been proposed. Disruption of dopamine activity in the brain has been repeatedly observed [104]; an interesting animal model of this effect has been described [105]. However, a clear picture of how HGPRT deficiency causes cerebral dopamine deficiency during development has not yet emerged.

16.6.2 Gout

- Genetic or dietary factors cause chronically increased urate production or retention
- Urate has limited solubility and may form crystalline deposits, preferentially in joints and soft tissue
- Urate crystals activate inflammation and lead to arthritis that is painful and, in the long run, destructive

Notes: The mechanism that links urate crystals to inflammation has been elucidated [62] and is similar to the one that applies to cholesterol crystals [61].

16.6.3 Diets and drugs that may promote gout

- too much food, too rich in purines
- excessive fructose or sucrose
- alcoholic beverages—but not all kinds: beer yes, wine no
- anorexia nervosa (!)
- drugs that interfere with uric acid secretion: pyrazinamide, salicylic acid
- drugs that contain purines: dideoxyadenosine

Notes: It seems that the uptake of purines and the subsequent production of uric acid are linearly related to purine ingestion [100]. Therefore, a purine-rich diet is a straightforward way to contract gout.

There are several plausible connections between alcohol and gout, of which no single one has unequivocally been shown to be the dominant one. Degradation of alcohol via alcohol dehydrogenase and then aldehyde dehydrogenase produces NADH, which shifts the equilibrium of the lactate dehydrogenase reaction from pyruvate to lactate (see slide 7.4.2). Lactate may increase the retention of uric acid in the kidneys by serving as an exchange substrate in tubular transport (see slide 16.5.4).

A statistical study found an association of beer, but not wine, consumption with gout [106]. The amounts of alcohol ingested by both groups were similar, suggesting that moderate consumption of alcohol as such does not promote gout. Beer is higher in calories and in purines than wine, which may account for the difference observed in this study.

Considering the association of a rich diet with gout, it seems surprising that *anorexia nervosa*, an eating disorder in which patients eat only the bare minimum required to ward off death, and sometimes less, may also lead to gout [107]. This has been ascribed to the formation of ketone bodies, which as organic acids may also serve as exchange substrates in the tubular reuptake of uric acid and thereby increase urate retention.

The drug 2,3-dideoxyadenosine inhibits retroviral reverse transcriptase and is used in the treatment of HIV infections (see slide 16.9.11). It undergoes degrada-

tion like other purine nucleotides and as such will contribute to uric acid production, which may occasionally trigger gout [108].

16.6.4 Gout: the fructose connection

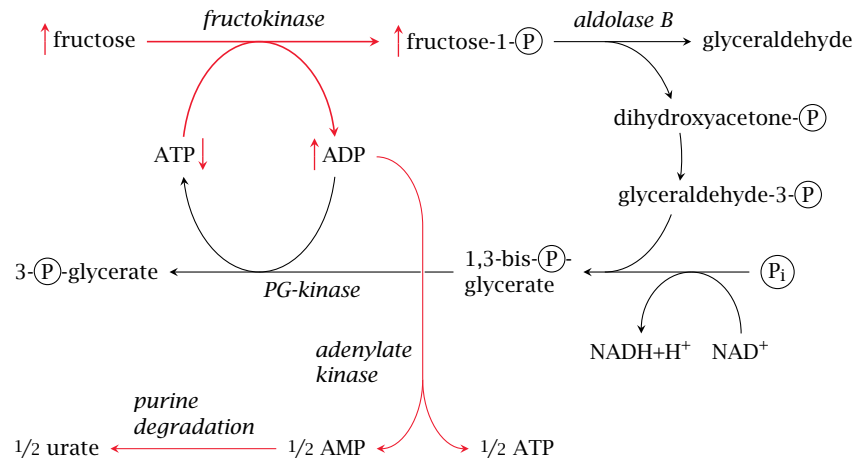

Notes: Fructose has been linked to increased uric acid production both experimentally [109] and statistically [110]. The mechanism is as follows: Fructokinase produces fructose-1-phosphate more rapidly than it can be turned over by aldolase B. This ties up phosphate, which is then no longer available for the regeneration of ATP. This raises the level of ADP, which is disproportionated by adenylate kinase to ATP and AMP, and the latter enters degradation via AMP deaminase (to IMP) or 5'-nucleotidase (to adenosine; see slide 16.5.1).

In keeping with the assumption that uric acid formation is promoted by limiting aldolase B activity, heterozygous carriers of a deficient gene for this enzyme experience a greater increase of urate synthesis in response to a fructose challenge than individuals with two intact gene copies [111]. As noted before, a homozygous defect of aldolase B causes hereditary fructose intolerance. In this condition, phosphate sequestration and ATP depletion reach a much greater extent, with much more immediate and disastrous consequences for the liver cells (see slide 4.2.2).

16.6.5 Drugs that affect purine degradation and elimination

Notes: Allopurinol is an inhibitor of xanthine dehydrogenase/oxidase. When it is used, hypoxanthine and xanthine will accumulate instead of uric acid. These intermediates are more soluble than uric acid and are readily excreted. Allopurinol is very effective and a mainstay in the treatment of gout.

Probenecid and benzbromarone are uricosuric drugs, that is, they increase the excretion of uric acid with the urine through inhibition of its tubular reuptake by the URAT1 transporter (see slide 16.5.4). The increased efficiency of urate excretion lowers the urate levels in blood and tissues, which in turn reduces the risk of precipitation in the joints. Uricosuric drugs also are widely used in gout therapy.

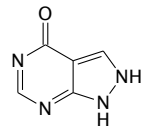

allopurinol

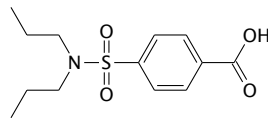

probenecid

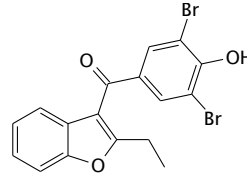

benzbromarone

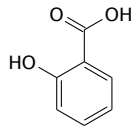

salicylic acid

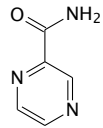

pyrazinamide

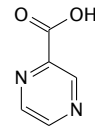

pyrazinoate

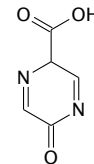

5-hydroxy-pyrazinoate

Some drugs or drug metabolites *promote* the tubular reuptake of uric acid, presumably by functioning as exchange substrates at the URAT1 transporter. This effect can occur with salicylic acid, and it is very pronounced with pyrazinoic acid and its 5-hydroxy derivative, the metabolites of the tuberculostatic drug pyrazinamide. Treatment with pyrazinamide, which is carried out over several months and at dosages of gram amounts per day, may therefore trigger gout.



16.5 Explain the mode of action of uricosuric drugs.

16.6.6 Acute urate nephropathy in tumor lysis syndrome

- Occurs during chemotherapy of malignancies, particularly with lymphomas and leukemias
- Chemotherapy causes acute decay of large numbers of tumor cells
- Degradation of nucleic acids from decaying cells produces large amounts of uric acid
- Uric acid in nascent urine exceeds solubility and precipitates, clogging up and damaging the kidney tubules
- Clinically manifest as acute kidney failure with high fatality rate

Notes: The underlying problem in acute urate nephropathy is again an excess of uric acid, but in this case it occurs very suddenly and on an altogether different scale than in simple gout. As a consequence, the capacity for reuptake in the proximal tubules is overwhelmed, and the excess uric acid appears in large quantities in the distal tubules. As water is reclaimed from the nascent urine, the uric acid becomes more concentrated. Moreover, the pH value in the distal tubule is often acidic, which will cause uric acid ($pK_a=5.75$) to become protonated and precipitate.

The condition is particularly common with lymphomas and leukemias. Unlike most other cancers, in which most tumor cells are contained in a single solid mass that is surgically removed prior to chemotherapy, leukemias and most lymphomas grow diffusely and are not amenable to surgical removal; therefore, chemotherapy

is used right from the start and impinges on a far greater number of malignant cells in the body. As a preventive measure, leukemia or lymphoma patients that undergo chemotherapy receive allopurinol concomitantly. This treatment has greatly reduced the incidence of acute urate nephropathy.

 **16.6** Explain the role of xanthine oxidase in purine degradation, and the therapeutic use of xanthine oxidase inhibitors in gout and in tumor lysis syndrome.

 **16.7** Would uricosuric drugs be useful in the treatment of tumor lysis syndrome? Why, or why not?

16.6.7 Rasburicase, a better preventive treatment for urate nephropathy

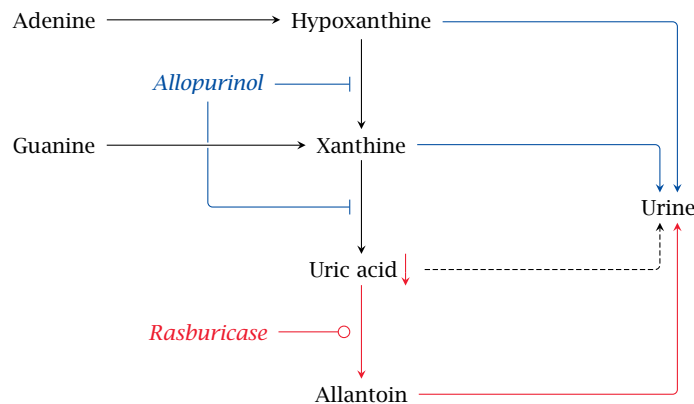

Notes: This slide shows the action modes of allopurinol and of *rasburicase*, which is an uricase enzyme from an *Aspergillus* mold that is recombinantly produced in baker's yeast (*Saccharomyces cerevisiae*). The enzyme will convert uric acid to allantoin (see slide 16.5.5). This mode of action complements the decreased formation of uric acid attained with allopurinol. Like the latter drug, rasburicase is used—by way of intravenous infusion—to prevent acute urate nephropathy in leukemia patients undergoing chemotherapy. Individually, rasburicase is superior to allopurinol, but it should also be possible to use both drugs in combination.

Since rasburicase is a non-self protein, it is immunogenic, and it thus may induce the formation of antibodies that inactivate it and additionally may cause allergic complications. This problem is mitigated by the immunosuppressive effect of chemotherapy and, in leukemia, of the disease itself. However, it will likely make rasburicase unsuitable for long-term use in gout patients [112].

16.7 Synthesis and degradation of pyrimidines

16.7.1 Synthesis of pyrimidines (1)

Notes: In contrast to the purine rings of AMP and GMP, which are assembled atop the phosphoribose moiety, the skeleton of the pyrimidine bases is synthesized before attachment to ribose phosphate.

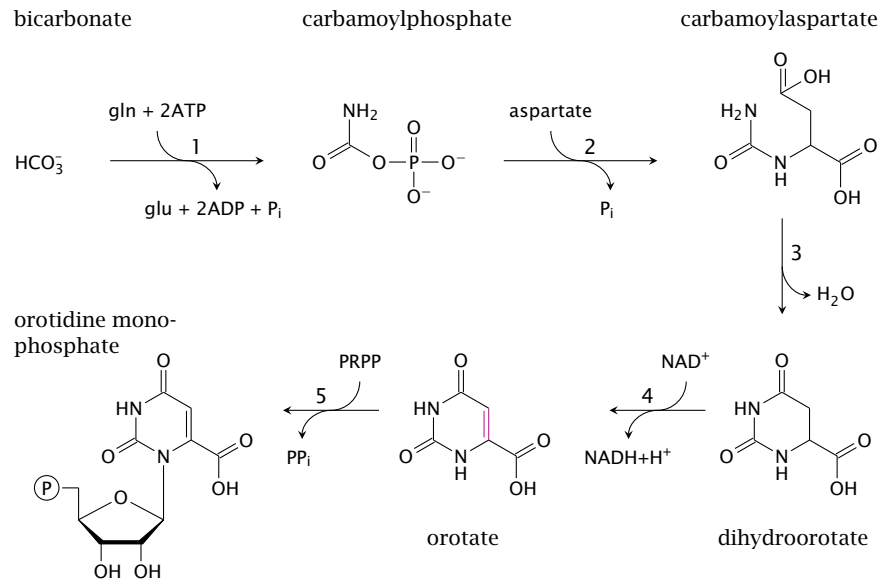

The first intermediate is carbamoylphosphate. The corresponding enzyme, carbamoylphosphate synthetase 2, uses glutamine as the nitrogen donor; in contrast, carbamoylphosphate synthetase 1, which occurs in the urea cycle, uses free ammonia directly (see slide 12.3.1).

In the second reaction, aspartate transcarbamylase transfers the carbamoyl group of carbamoylphosphate to the α -amino group of aspartate, which yields carbamoylaspartate. Ring closure through intramolecular Schiff base formation (3) yields dihydroorotate, and subsequent dehydrogenation (4) produces orotate. Orotate phosphoribosyltransferase (5) forms orotidine-5'-monophosphate (OMP), in a reaction that resembles purine salvage (compare slide 16.5.6). Indeed, this enzyme has relatively broad specificity and also functions in the salvage of uracil and in the activation of its analogue 5-fluorouracil (see slide 16.9.1).

16.7.2 Synthesis of pyrimidines (2)

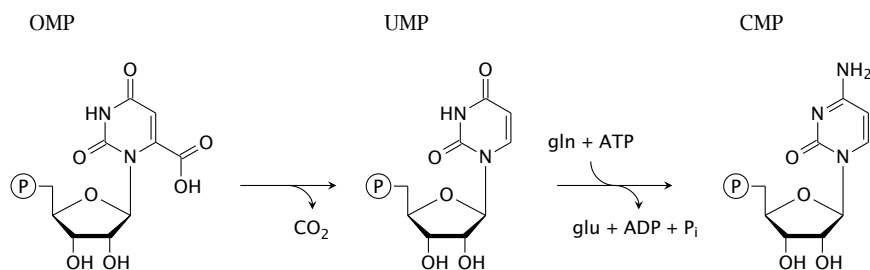

Notes: From OMP, it is only a short way to the final pyrimidine nucleotides. Decarboxylation of OMP yields UMP directly; glutamine donates another nitrogen in the synthesis of CMP from UMP.

16.7.3 Degradation of pyrimidines

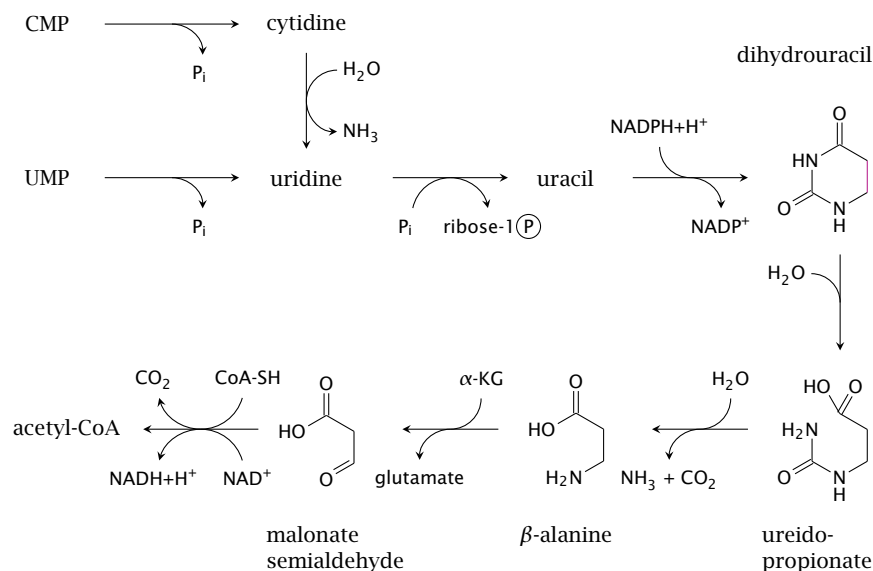

Notes: Like their synthesis, degradation of pyrimidine bases is also fairly straightforward. Cytidine is deaminated to uridine. Pyrimidine nucleoside phosphorylase cleaves uridine to free uracil and ribose-1-phosphate. One of the amide bonds in the uracil ring is opened through hydrolysis, and ammonia and CO_2 are cleaved off to produce β -alanine. This compound may be excreted with the urine, or it may be transaminated and converted to acetyl-CoA.²

Thymine is degraded in the same manner as uracil, producing methylated analogues each step along the way. In the final step, methylmalonyl-semialdehyde gives rise to propionyl-CoA, which is utilized as outlined in slide 10.3.6.



16.8 Explain the degradation of pyrimidine nucleosides.

16.7.4 β -Alanine may be used to synthesize carnosine

Notes: Carnosine is a dipeptide of β -alanine and histidine. It is found in high concentrations (~ 5 mM) in muscle; lower concentrations are found in nerve cells. One intriguing property is illustrated here, namely, its reaction with hydroxyl radicals, which results in the formation of a more stable carnosine radical [113]. Hydroxyl radicals are produced by ionizing radiation and mediate most of the cellular damage caused by radiation. The animal experiment depicted in the plot [114] suggests that carnosine may scavenge those radicals and reduce the inflicted damage. Note though that the number of mice used in this experiment was rather small.

While numerous biological activities have been proposed for carnosine, the most important one is likely to buffer the lactic acid that accumulates in skeletal muscle during anaerobic exercise. The pK_a value of carnosine is very close to the

²Unlike regular alanine, β -alanine carries the amino group on the second carbon from the carboxyl group. This position is also referred to as the β carbon, whereas the first one is the α carbon.

physiological intracellular pH, which maximizes buffer capacity. Carnosine and its methylated analogue ophidine are highly abundant (40–50 mM) in the muscle tissue of whales. Most likely, this large buffer capacity helps the whales to sustain extended periods of anaerobic muscle metabolism during their dives to the deep [115].

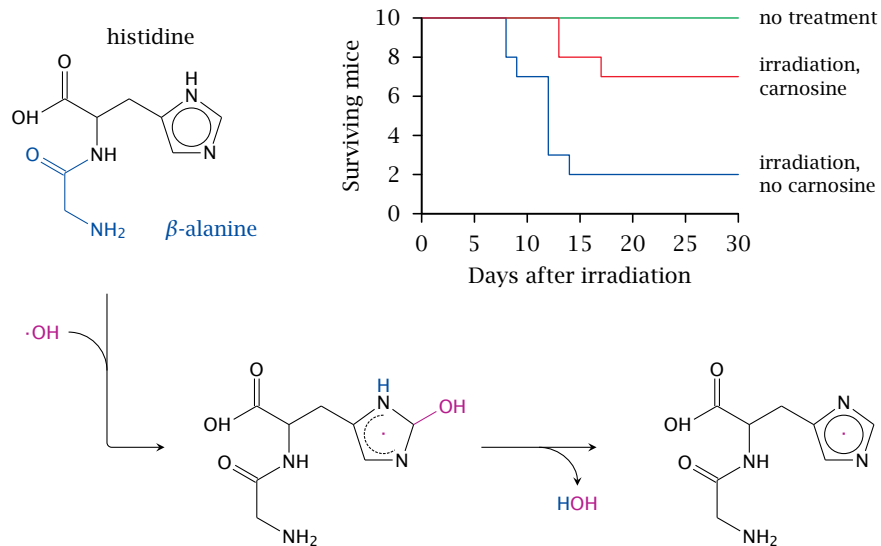

16.8 Synthesis of deoxyribonucleotides

Notes: The synthetic pathways covered so far all produce ribonucleotides. In addition, we also need deoxyribonucleotides as precursors for DNA synthesis. These are made from ribonucleotides.

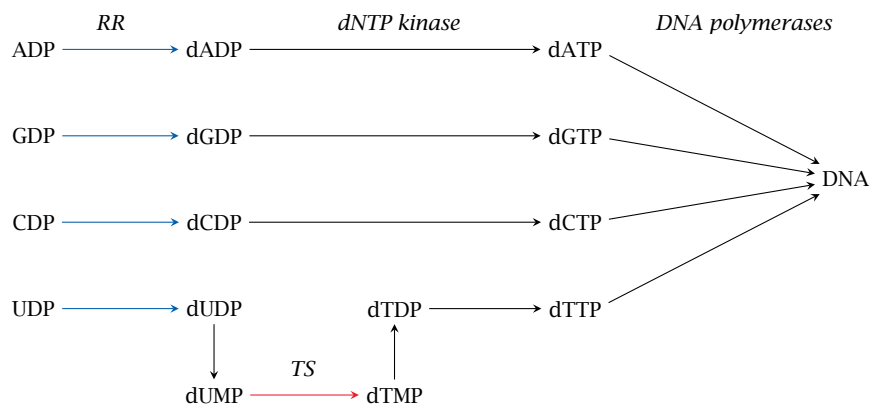

The conversion of ribonucleotides to deoxyribonucleotides occurs at the level of the nucleoside diphosphates. All four ribonucleotides—ADP, CDP, GDP and UDP—are reduced by the same enzyme, ribonucleotide reductase (RR). This reaction requires NADPH.

With dA, dC and dG, the deoxytriphosphates are then obtained simply through ATP-dependent phosphorylation by nucleoside diphosphate kinase. In contrast,

uracil still has to be converted to thymine for the purpose of DNA synthesis. In order to prevent incorporation of uracil into DNA, dUDP is first dephosphorylated to dUMP by a cognate phosphatase. dUMP then enters the thymidylate synthase reaction (TS); the product, dTMP, is phosphorylated twice to produce dTTP.



16.9 Explain the role and synthetic pathway of deoxyribonucleotides.

16.8.1 The thymidylate synthase reaction

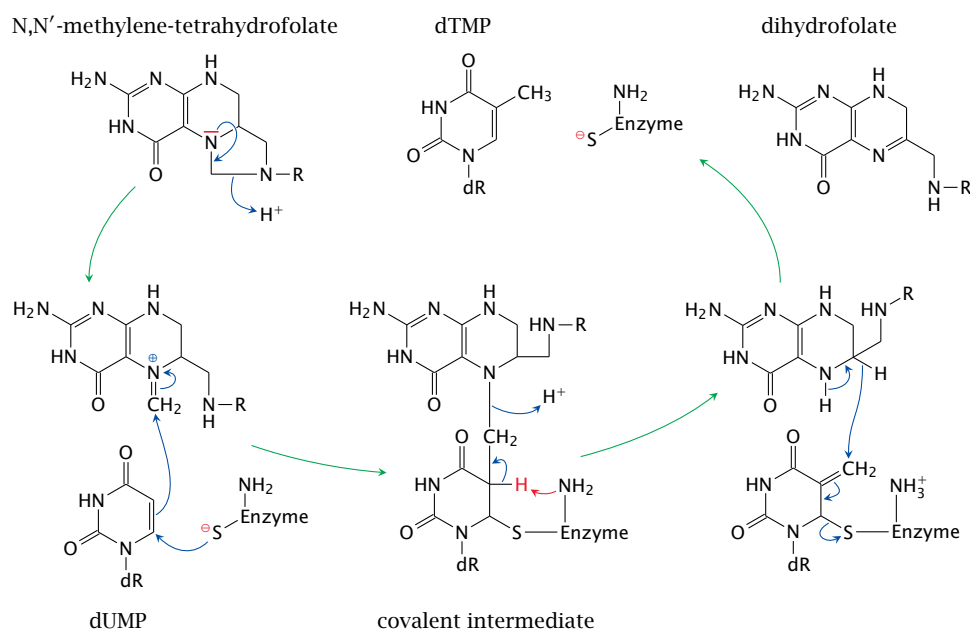

Notes: Thymidylate synthase acquires a single carbon from the cosubstrate *N,N'*-methylene-tetrahydrofolate (methylene-THF) and transfers it to dUMP. The reduction of the methylene carbon to the methyl group as found in the product (dTMP) occurs at the expense of THF, which is thereby converted to dihydrofolate and has to be reduced again to THF by dihydrofolate reductase (see slide 15.2.2).

Note that, halfway through the reaction, the enzyme, the substrate, and the co-substrate are all joined together in a covalent intermediate, which is then resolved through the abstraction of a proton from position 5 of the uracil by a catalytic base in the enzyme's active site (red arrow). This mechanism forms the basis of the inhibition of thymidylate synthase by the antitumor drug 5-fluorouracil (see slide 16.9.1).

16.9 Nucleotide antimetabolites as anticancer and antiviral drugs

Notes: Nucleotide analogues are of major importance in the chemotherapy of both cancers and virus infections. With antiviral drugs, selective toxicity for virus-infected cells is possible, because viral enzymes often differ from the analogous human ones with respect to their susceptibility to specific inhibitors. In contrast, the same kind of selectivity is not possible with cancer cells, which have the

same enzymes as noncancerous cells do; antimetabolites that kill cancer cells are invariably toxic to noncancerous cells also. However, cancer cells are often more susceptible to these cytotoxic drugs because they are more readily driven by them into *apoptosis*, that is, programmed cell death (see slide 18.5.1), which is triggered by a various forms of DNA damage.

Therapeutic principle	Examples
direct inhibition of DNA/RNA polymerization	dideoxyadenosine, cytosine arabinoside, acyclovir
inhibition of nucleotide synthesis	mercaptopurine, fluorouracil, methotrexate
Incorporation of mutagenic analogues into DNA	idoxuridine

As will become clear from the discussion of individual examples below, some drugs can cause interference by more than one mechanism.

16.9.1 Dual action mode of 5-fluorouracil

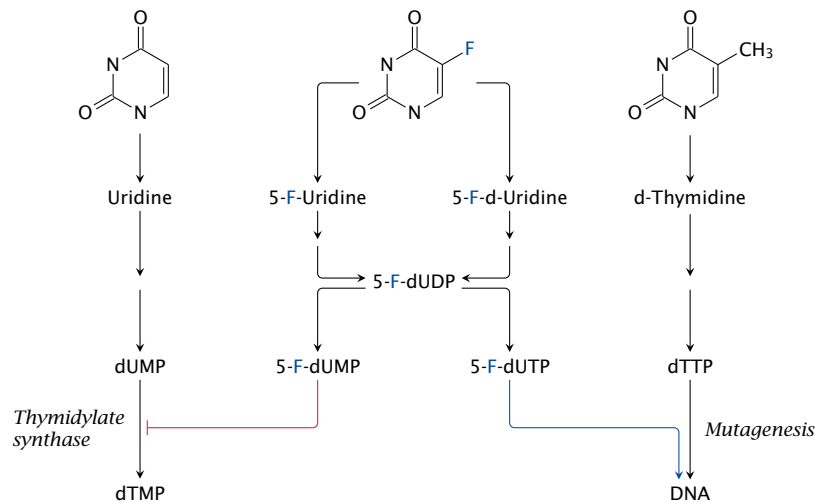

Notes: 5-fluorouracil (5-FU) is a base analogue that mimics both uracil and thymine. The dual resemblance endows it with a twofold mode of metabolic activation and of action. One of several initial activation products, 5'-fluorodeoxyuridine, is also used as a drug itself.

The metabolic activation of 5-FU occurs along the so-called salvage pathways that recycle bases and nucleosides released by nucleic acid degradation. 5-FU is activated by the same enzymes that salvage uracil. A key activation product is 5-FdUMP, which is a suicide substrate for thymidylate synthase (see next slide). This is its major mode of action and the one that makes it an antimetabolite.

5-FU is also activated by enzymes that salvage thymine and thus may wind up as 5'-fluoro-dUTP, which is incorporated into DNA; this will cause point mutations (see slide 16.9.3).

16.9.2 Inhibition of thymidylate synthase by 5-fluorouracil

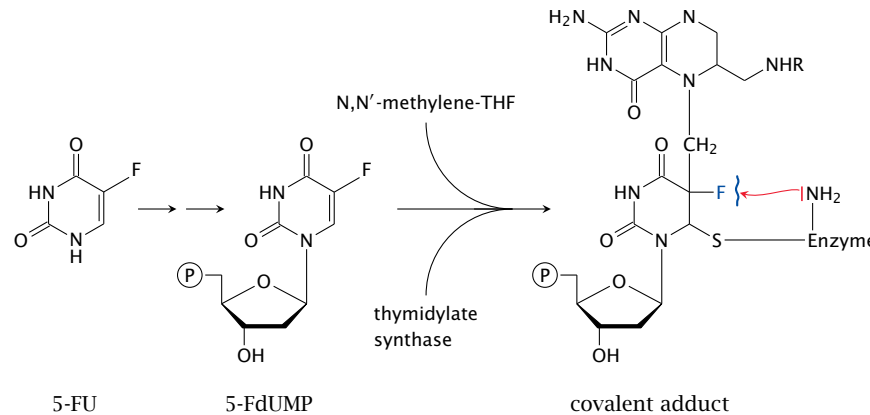

Notes: 5'-Fluorouridine monophosphate (5-FdUMP) is accepted by thymidylate synthase as a substrate and reacts with methylene-THF and the enzyme right up to the point where all three are joined in a covalent intermediate (slide 16.8.1). At this stage, however, the fluorine in position 5 of the uracil resists abstraction by the catalytic base of the enzyme. The covalent intermediate therefore cannot be resolved, and the enzyme molecule remains irreversibly locked up.

Inhibition of thymidylate synthase will starve the cell of thymine required for DNA synthesis. Fluorouracil has shown particularly good activity in colon cancer, but there seems to be no known biochemical reason to account for this empirical rule.

16.9.3 Mutagenesis through mispairing of the 5-FU iminol tautomer

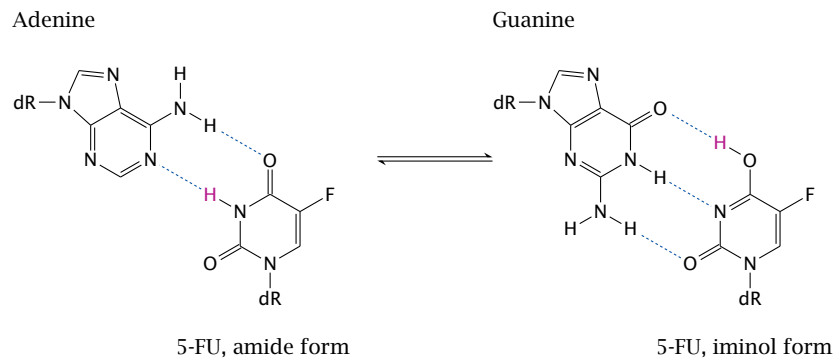

Notes: 5-F-dUTP can be incorporated into DNA and promote point mutations. This is due to the fluorine, which withdraws electrons from the ring; this, in turn, pulls electrons into the ring from other substituents and encourages the molecule to

assume the iminol configuration. In this configuration, the base no longer pairs with adenine but with guanine.

If the iminol configuration is present during DNA replication, guanine will be chosen for incorporation into the opposite strand. This mutagenic effect of 5-FU augments its anticancer effect.

16.9.4 Thymine and various halogen analogues

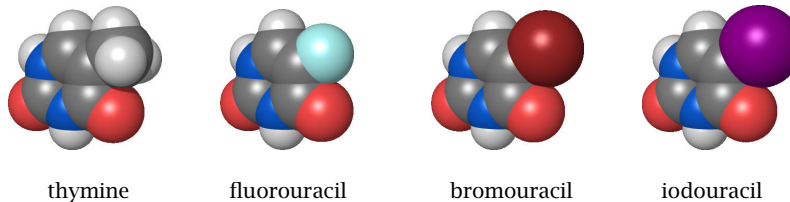

Notes: The bromo- and iodo-analogs of deoxythymidine, 5-bromouracil-deoxyriboside (5-BUdR) and 5-iodouracil-deoxyriboside (idoxuridine), are also incorporated into DNA. Bromine and iodine are larger than fluorine and similar to a methyl group in size. Therefore, the activated triphosphates more closely resemble dTTP and are more effectively incorporated than the fluoro-derivative.

Like fluorouracil, idoxuridine is used in tumor therapy. 5-BUdR is not used clinically but has in the past been widely used for shotgun mutagenesis experiments in genetic research.

16.9.5 Indirect inhibition of thymidine synthesis by methotrexate

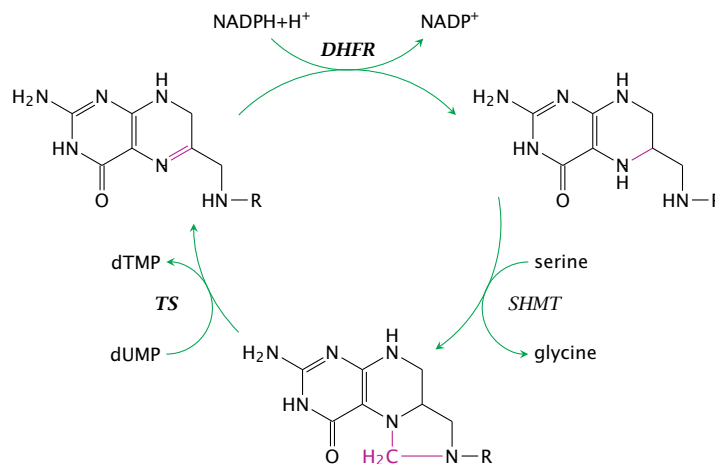

Notes: Methotrexate is an inhibitor of dihydrofolate reductase (see slide 15.2.2). This enzyme is required to reduce the dihydrofolate produced by the thymidylate synthase reaction to THF again, so that it can accept another carbon from serine hydroxymethyltransferase or another enzyme.

Methotrexate can be used in tumor therapy. Because it is not a nucleotide analogue and does not react with DNA, it is not mutagenic, which makes it more

suitable than most base analogues in antiproliferative therapy not related to tumors. In particular, methotrexate is used to suppress lymphocyte proliferation in severe autoimmune diseases such as rheumatoid arthritis or Crohn's disease.



16.10 Explain the synthetic pathway for deoxythymidine triphosphate (dTTP), starting with UDP. Explain how 5-fluorouracil and methotrexate interfere with this pathway.

16.9.6 Mercaptopurine inhibits purine synthesis

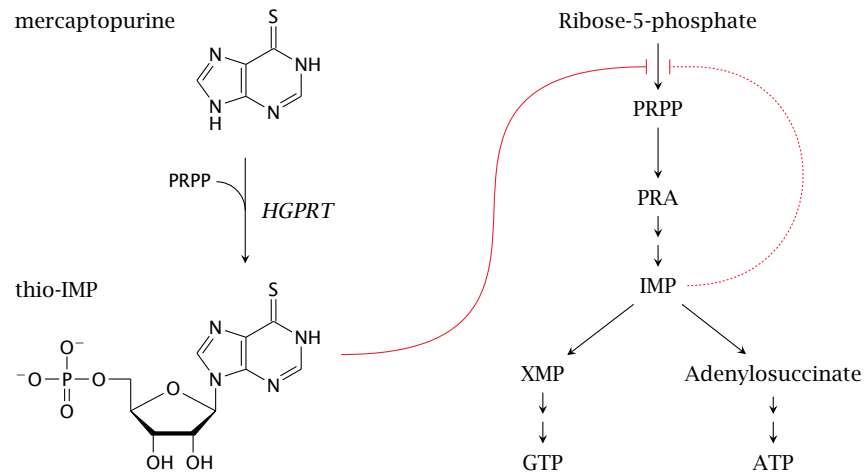

Notes: Mercaptopurine is activated to a nucleotide analogue by HGPRT, which also salvages the endogenous bases hypoxanthine and guanine (see slide 16.5.6). The analogue is not steered efficiently toward DNA incorporation. Instead, its main effect consists in the inhibition of *de novo* purine synthesis, by way of its similarity to inosine monophosphate, which inhibits the first enzyme in the pathway (ribose phosphate diphosphokinase). The related drug thioguanine acts in a similar manner. Lack of DNA incorporation means low mutagenicity; like methotrexate, the two drugs are used not only in cancer but also in immunosuppressive therapy.

Mercaptopurine and thioguanine are metabolized through methylation by thiopurine methyltransferase, which uses *S*-adenosylmethionine as a cosubstrate. A defect of that enzyme, as such, has no manifest symptoms, but when treated with either drug these individuals may suffer severe *myelosuppression*, that is, disrupted cell proliferation in the bone marrow. It is therefore advisable, and in some cases mandatory, to test patients' enzyme activities before using these drugs.

Mercaptopurine is also metabolized by xanthine dehydrogenase/oxidase. Combination of mercaptopurine with xanthine oxidase inhibitors such as allopurinol can again result in bone marrow toxicity, but is sometimes used deliberately to increase the immunosuppressive effect.

16.9.7 Structure of cytosine arabinoside (araC)

Notes: Cytosine arabinoside (cytarabine, araC) deviates from the normal cytosine nucleotides not in the base but in its sugar moiety, arabinose, which is epimeric to

16.9.9 Overexpression of 5'-nucleotidase in leukemic cells reduces survival rates

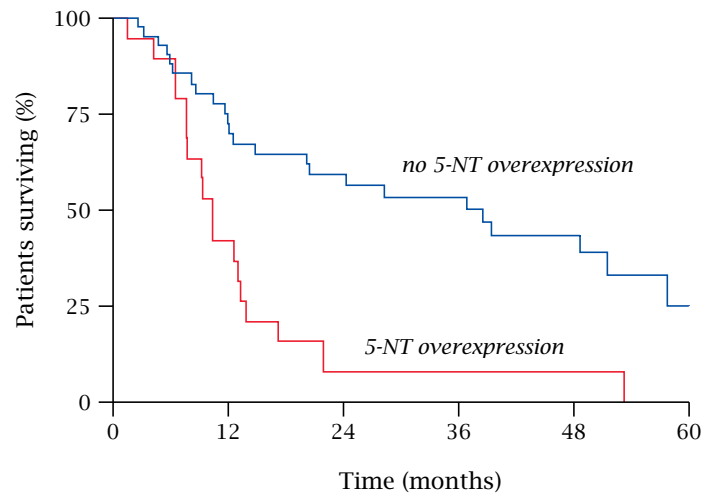

Notes: AraC is an important drug in the treatment of acute myeloid leukemia (AML). This plot shows that reduced susceptibility to araC due to increased expression of 5'-nucleotidase correlates with a significantly reduced duration of relapse-free survival in AML patients. Figure prepared from original data in [116].

16.9.10 Action mode of araCTP

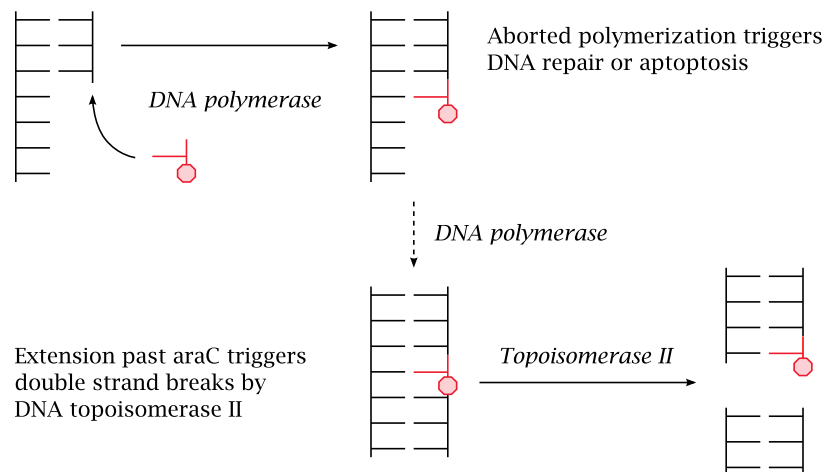

Notes: AraCTP is accepted as a substrate by DNA polymerase and becomes incorporated into a growing DNA strand. The polymerase may or may not manage to continue past an incorporated araC molecule. If it does not, DNA repair will be activated, and the base will be excised and replaced; this amounts to a delay of DNA synthesis and constitutes a proapoptotic signal.

If DNA polymerase does manage to continue past an incorporated araC molecule, the latter becomes part of a continuous DNA double strand. Such interposed araC residues then become preferred substrate sites for DNA topoisomerase II,

which cleaves the DNA double strand [117]. Resealing of the double strand may fail and lead to chromosome breaks.

16.9.11 Dideoxyadenosine inhibits retroviral DNA polymerase

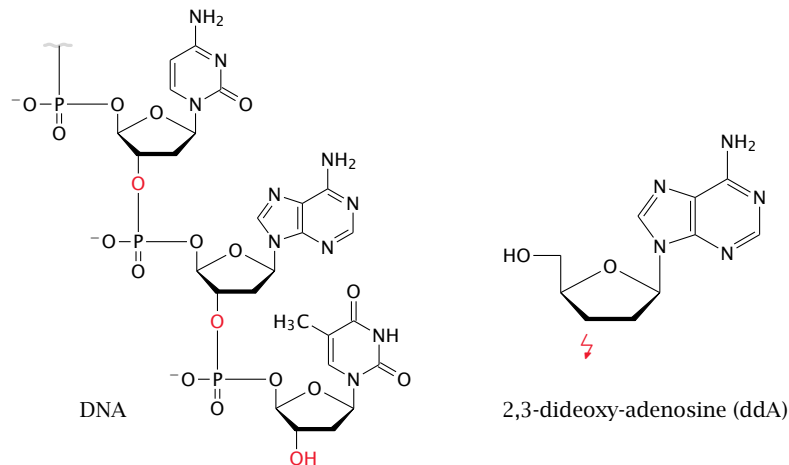

Notes: Base and nucleoside analogues are also useful in the treatment of viral diseases. An example is dideoxyadenosine (didanosine, ddA), which lacks the 3-OH group of the deoxyribose moiety. Since the 3- and the 5-OH groups form the bonds within the DNA strand, incorporation of ddA into a growing DNA strand causes termination of synthesis.³

The cellular DNA polymerases do not efficiently incorporate ddA, so it has limited cytotoxicity. However, the reverse transcriptase enzymes in retroviruses such as HIV use ddA efficiently, which leads to disruption of viral DNA synthesis. Inhibitors of reverse transcriptase such as ddA are a standard component of HIV therapy.

As stated above (slide 16.6.3), long-term application of didanosine may promote the manifestation of gout.

16.9.12 Aciclovir and ganciclovir

aciclovir

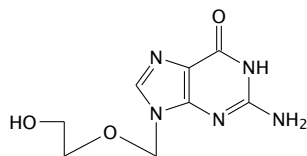

ganciclovir

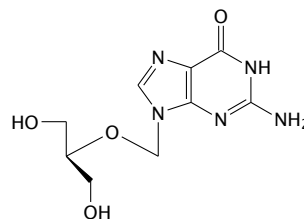

Notes: Aciclovir (or acyclovir) and ganciclovir are even more severely crippled than dideoxyadenosine, and it is quite remarkable that some enzymes even accept

³You may recall that base-specific chain termination by dideoxy-nucleotides is the basis of the Sanger method of DNA sequencing. If you don't, consider yourself reprimanded.

them as substrates. This is the case with enzymes of viruses from the Herpes group, which includes herpes simplex virus, cytomegalovirus, varicella zoster virus and a bunch of others. These are relatively large and complex viruses, which contain not only the bare minimum of enzymes such as nucleic acid polymerases but also their own nucleotide kinases.

16.9.13 Aciclovir: mode of action on herpes virus

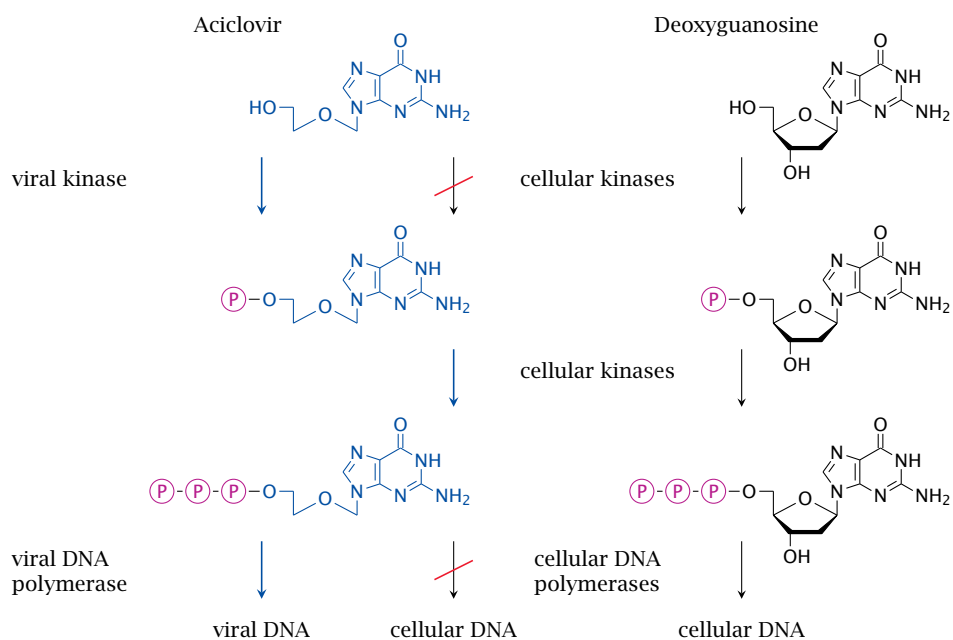

Notes: The selective toxicity of aciclovir for Herpes virus-infected cells, as opposed to normal cells, arises at two stages. Firstly, aciclovir is phosphorylated to the monophosphate only by viral nucleoside kinase, but not by the cellular enzyme. Secondly, the triphosphate, which is formed from the monophosphate by cellular kinases, is accepted as a substrate only by the viral DNA polymerase. This dual mechanism of selective toxicity causes aciclovir to be well tolerated yet effective.



16.11 Explain the modes of action of the antiviral drugs dideoxyadenosine and aciclovir.

16.9.14 Some more inhibitors of viral nucleic acid synthesis

Notes: Foscarnet is an unusual drug. It is an analogue of pyrophosphate, which is released in each successive addition of a nucleotide to a growing DNA or RNA strand, and subsequently cleaved to phosphate:

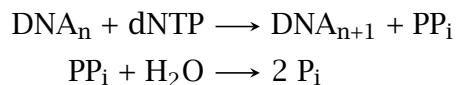

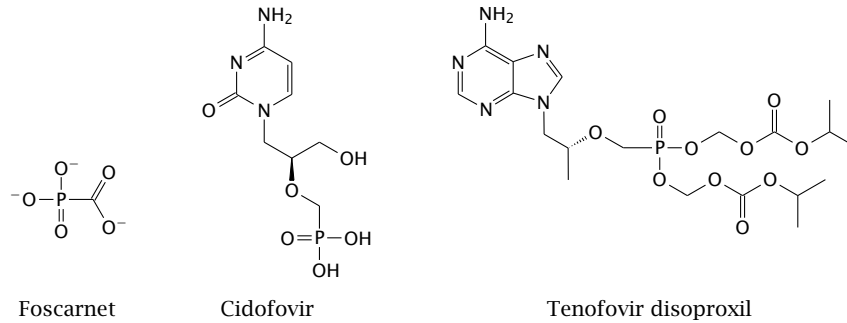

Nucleic acid polymerases contain binding sites for the pyrophosphate (PP_i) that is formed in the first step. Fosfocarnet lodges into the pyrophosphate binding sites on several viral polymerases. Unlike pyrophosphate, fosfocarnet is resistant to hydrolysis; it therefore remains bound to the polymerase enzymes and inhibits their activity.

Cidofovir is similar to aciclovir in having a mutilated ribose moiety. In addition, it also carries a phosphonate group; it therefore functionally resembles a nucleoside monophosphate and does not require the initial phosphorylation step, which gives it a broader spectrum than aciclovir. After addition of two more phosphates to this phosphonate group by cellular kinases, the drug inhibits several viral DNA polymerases.

Tenofovir disoproxil follows the same principle as cidofovir. However, it additionally carries two ester groups on the phosphonate. These groups make the drug more hydrophobic, which facilitates its diffusion across cell membranes. This improves the efficiency of intestinal uptake and distribution within the body. After cellular uptake, the ester groups are cleaved by esterases, which traps the molecule inside the cell and allows it to interact with nucleotide kinases and polymerases.

16.10 Answers to practice questions

16.1: The RNA world is a hypothetical stage in the molecular evolution of life that predates the current biochemical world. In the RNA world, RNA assumed the roles of DNA and of protein enzymes in addition to the ones it still owns today.

In the current biochemical world, enzymes almost completely consist of proteins. However, many coenzymes still contain nucleotides rather than peptides. A possible explanation is that coenzymes had become involved in interactions with many different enzymes early on, which restrained their evolutionary freedom.

16.2: The synthesis of the purine nucleotides AMP and GMP follows a common route from 5'-phosphoribosyl-1'-pyrophosphate (PRPP) to inosine monophosphate (IMP). In the initial and committed step, the pyrophosphate group of PRPP is replaced by an amino group derived from glutamine, which yields phosphoribosylamine (PRA). In nine successive steps, the purine ring is built atop this amino group, which becomes the N1 member atom of the ring. The carbons are supplied variously by glycine, CO_2 and formyl-THF, whereas the nitrogens are acquired from glycine, aspartate, and glutamine.

AMP and GMP are synthesized from IMP in two steps each. They can be converted back to IMP in a single step, and therefore balanced with one another according to current metabolic needs. AMP and GMP exert feedback inhibition on their own synthesis from IMP.

Adenine and guanine nucleotides also inhibit the committed step (PRA synthesis), and IMP inhibits the formation of PRPP from ribose phosphate.

16.3: Ribose can be converted to glucose in the HMS; therefore, 1 mole of ribose will be converted to $\frac{5}{6}$ moles of glucose. Deoxyribose, as its 5-phosphate, is cleaved by a cognate aldolase to glyceraldehyde-3-phosphate and acetaldehyde. The former can enter glycolysis or gluconeogenesis, whereas the latter is converted to acetyl-CoA, which in human metabolism cannot be converted to glucose.

Two molecules of glyceraldehyde-3-phosphate are required to make one molecule of glucose; therefore, the maximal yield of glucose would be 1 molecule of glucose for 2 molecules of deoxyribose. Therefore, ribose provides $\frac{5}{3}$ times more glucose than deoxyribose.

16.4: Dietary DNA and RNA are broken down by pancreatic DNase and RNase, respectively. After dephosphorylation, the nucleosides are taken up by specific transport and degraded in the liver. The sugars are cleaved by phosphorylases, which yields deoxyribose- and ribose-1-phosphates. Purines are broken down to uric acid and excreted; pyrimidines are broken down mostly to β -alanine and either excreted as such or completely degraded to acetyl-CoA. The sugar 1-phosphates are first converted to 5-phosphates by pentose phosphate mutase and utilized by the hexose monophosphate shunt (ribose-5-phosphate) or by cleavage to glyceraldehyde-3-phosphate and acetaldehyde (deoxyribose-5-phosphate).

16.5: Uricosuric drugs competitively inhibit the tubular reuptake of uric acid by the URAT1 transporter. This accelerates the renal excretion of uric acid.

16.6: In purine degradation, adenine and guanine are converted by deamination to hypoxanthine and xanthine, respectively. Xanthine oxidase converts hypoxanthine to xanthine, as well as xanthine to uric acid. Uric acid is the final product of purine degradation and is excreted.

Uric acid has limited solubility, and increased levels of uric acid lead to its precipitation or crystallization in joints (gout) or in the kidneys. The latter occurs most acutely and dramatically in tumor lysis syndrome during chemotherapy; this is most common in leukemia. In both conditions, inhibition of xanthine oxidase prevents the final oxidation steps, leading to the excretion of hypoxanthine and xanthine of uric acid. These are more soluble than uric acid and therefore less prone to precipitate prior to excretion.

16.7: In tumor lysis syndrome, uricosuric drugs would only further accelerate the buildup of uric acid inside the kidney tubules and would make matters worse.

16.8: Cytidine is deaminated to uridine by cytidine deaminase. Uridine is cleaved by a phosphorylase to uracil and ribose-1-phosphate. The uracil ring is then opened through hydrolysis, and cleavage of ammonia and CO_2 gives β -alanine. The latter can be further degraded by transamination and dehydrogenation to acetyl-CoA, or alternatively it can be used for the synthesis of carnosine.

The degradation of thymidine is analogous and produces methylated analogs, with propionyl-CoA as the final product.

16.9: Deoxyribonucleotides function exclusively as precursors of DNA. Deoxyribonucleoside diphosphates—dADP, dCDP, dGDP and dUDP—are formed from the corresponding ribonucleoside diphosphates by the same enzyme, ribonucleotide reductase. All except dUDP are then phosphorylated to the triphosphates.

In contrast, dUDP first undergoes dephosphorylation to dUMP and is then converted by thymidylate synthase to dTMP. The latter is then phosphorylated to dTDP and finally to dTTP.

16.10: UDP is converted to dUDP by ribonucleotide reductase and then dephosphorylated to dUMP. Thymidylate synthase transfers the C_1 from N,N' -methylene tetrahydrofolate to

position 5 of the uracil base in dUMP, producing dTMP. This reaction proceeds through an intermediate state in which methylene-THF, uracil and the enzyme are all covalently linked. Subsequently, dTMP is phosphorylated twice to dTDP and then dTTP.

5-Fluorouracil is activated to 5-dUMP via salvage reactions. It functions as a substrate analogue for thymidylate synthase. The reaction stalls at the stage of the covalent reaction intermediate; since the enzyme is unable to abstract fluorine from the uracil ring, it remains trapped in the covalent intermediate.

In the thymidylate synthase reaction, *N,N'*-methylenetetrahydrofolate is converted to dihydrofolate, which needs to be reduced by dihydrofolate reductase before it can acquire another C₁ subunit and supply it to thymidylate synthase. Methotrexate inhibits dihydrofolate reductase and therefore indirectly inhibits dTMP synthesis.

16.11: Dideoxyadenosine lacks the 3-OH group in the ribose moiety to which the next nucleotide would be attached in DNA synthesis. Therefore, its incorporation into a growing DNA strand will cause synthesis to terminate. It is not an efficient substrate for human DNA polymerase but is readily accepted by retroviral reverse transcriptase, and is accordingly used in the treatment of HIV infections.

Aciclovir is used to treat herpes virus infections. It has a rudimentary sugar moiety in which the carbons 2 and 3 of ribose are altogether lacking. It is not an efficient substrate of human nucleoside kinases, yet it is phosphorylated by herpes virus nucleoside kinase. Moreover, the triphosphate inhibits herpes virus DNA polymerase but not the human enzyme.

Chapter 17

Iron and heme metabolism

17.1 Structure and function of heme

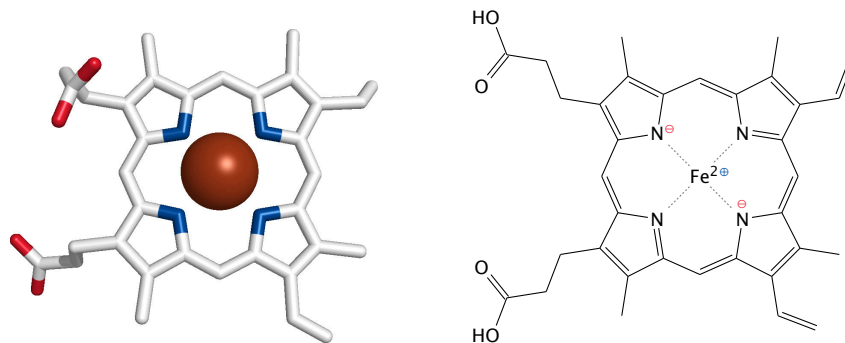

Notes: Heme consists of a *porphyrin* ring that holds a central iron ion. “Porphyr” is the name of purple-colored gemstone. Heme is colored, too, but its color varies with the protein it is bound to and with the oxidation state of the iron. In addition to hemoglobin, heme is also found in many *cytochromes*, a term that literally translates as “cell color” and comprises various classes of enzymes and electron carriers. The red-brown colors of tissues like liver, kidney, and brown fat are due to their abundance of heme-containing enzymes or of mitochondria, which contain many heme cofactors within the proteins of the electron transport chain.

In this chapter, we will focus on the biosynthesis and degradation of heme itself. The roles of heme in the respiratory chain and in cytochrome P450 enzymes are covered in chapters 6 and 18, respectively.

17.1.1 Functions of heme

Redox chemistry

- electron transport: cytochromes in the respiratory chain
- enzyme catalysis: cytochrome P450, cyclooxygenase, others

Reversible binding of gases

- O₂: hemoglobin and myoglobin (80–90% of all heme)
- NO: guanylate cyclase

Notes: In hemoglobin and myoglobin, the heme iron remains in the *ferrous* or Fe²⁺ state throughout the cycle of oxygen binding and release. In redox-active enzymes and in the respiratory chain, heme regularly goes back and forth between the ferrous and the *ferric* or Fe³⁺ states, and sometimes also the *ferryl* or Fe⁴⁺ state.

In cytochrome P450 enzymes, the function of heme is to facilitate the formation of reactive oxygen (see slide 18.2). Similarly, formation of reactive oxygen species (ROS) may also occur as a side reaction wherever heme functions in transport of oxygen or of electrons, and protective mechanisms are required to contain damage by ROS. In hemoglobin, molecular oxygen (O₂) may abscond with an extra electron and thereby turn itself into superoxide (O₂⁻), while the heme iron is left one electron short. Hemoglobin that has lost one electron is called *methemoglobin*; it is unable to carry oxygen. Its iron is reduced to the ferrous form again by an NADH-dependent enzyme, methemoglobin reductase.¹

Protective mechanisms that scavenge reactive oxygen species include the enzymes superoxide dismutase and catalase, as well as antioxidants such as tocoopherol (vitamin E; see slide 11.6.11) and ascorbic acid (vitamin C). Organisms that lack such protective mechanisms are *anaerobic*, that is, they survive only in the absence of oxygen. Anaerobic organisms occur among both prokaryotes and eukaryotes.



17.1 Summarize the biochemical and physiological functions of heme.

17.2 Heme biosynthesis

17.2.1 Overview

Notes: Heme contained in the food is taken up from the intestines, but this is only relevant because of the iron it contains. The organic porphyrin ring is mostly synthesized from scratch. The synthetic pathway is split across two compartments;

¹Methemoglobin reductase also participates in reductive metabolism of drugs and xenobiotics (see section 18.4). In that context, it is often referred to as *diaphorase*.

Interestingly, methemoglobin binds cyanide ions more avidly than reduced hemoglobin does. This is used in the treatment cyanide poisoning: Controlled application of oxidizing agents—such as dimethylaminophenol or sodium nitrite, [118]—turns some hemoglobin into methemoglobin, which then captures cyanide and prevents its binding to hemes in the respiratory chain. It seems, however, that treatment with hydroxycobalamin is superior (see slide 15.5.5)

the initial and final steps occur in the mitochondria, while the intervening ones occur in the cytosol. Heme exerts feedback inhibition on the first step in the pathway.

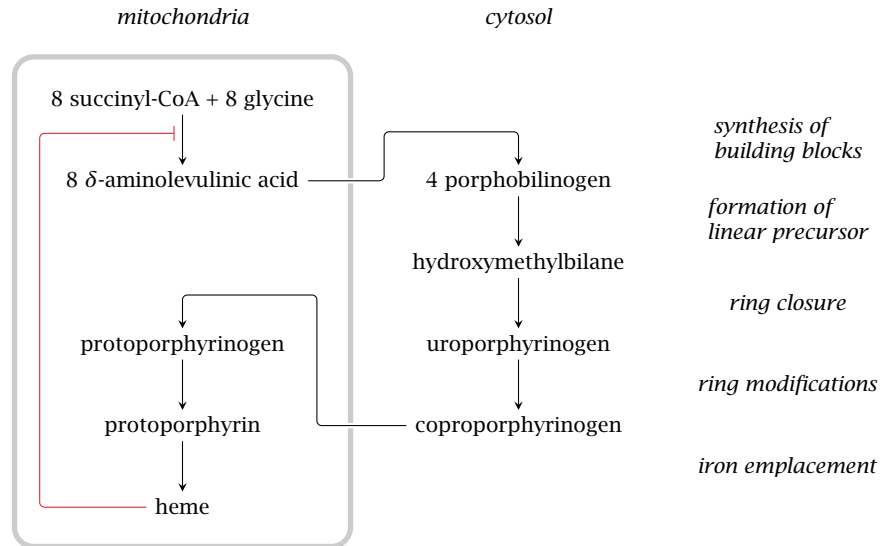

17.2.2 The δ -aminolevulinate synthase reaction

Notes: The first reaction in the porphyrin synthesis pathway occurs in the mitochondria. Glycine forms a Schiff base with pyridoxal phosphate (PLP) in the aminolevulinate synthase enzyme. Pyridoxal phosphate acts as a transient “electron sink”, as it usually does and as is illustrated for serine hydroxymethyltransferase in slide 15.2.4. Decarboxylation of the enzyme-bound glycine produces a carbanion intermediate, which reacts with the carbonyl carbon in succinyl-CoA.

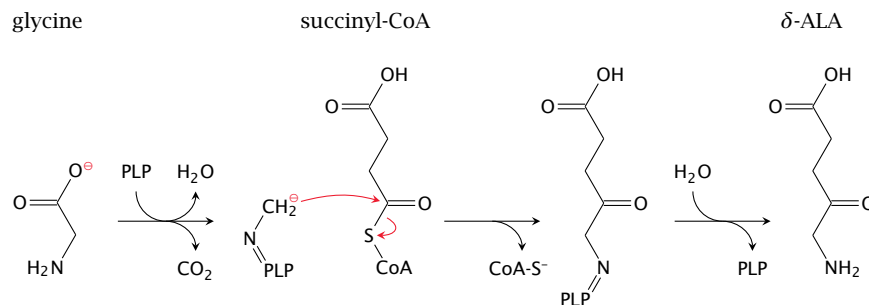

The aminolevulinate synthase reaction is the committed step of heme synthesis and is subject to feedback inhibition by heme, the final product of the pathway. The reaction product, δ -aminolevulinic acid (δ -ALA), is transported to the cytosol, where the next four reactions occur.



17.2 What is the committed step of heme biosynthesis, and how is it regulated?

17.2.3 The porphobilinogen synthase reaction

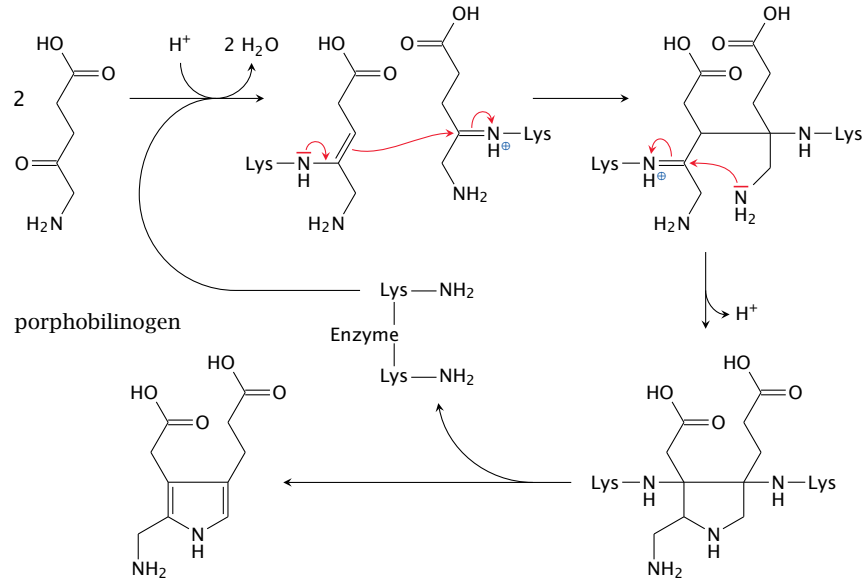

Notes: In the second reaction of heme synthesis, porphobilinogen synthase condenses two molecules of δ -ALA into one molecule of porphobilinogen, with the elimination of two molecules of water. At the outset, both substrate molecules form Schiff bases with two separate lysine residues in the active site. The water is already lost at this stage; however, the more interesting reaction steps that lead to the formation of the pyrrole ring still lie ahead. It should be noted that the reaction mechanism depicted here is still somewhat tentative [119].

17.2.4 A substrate analogue inside the active site of porphobilinogen synthase

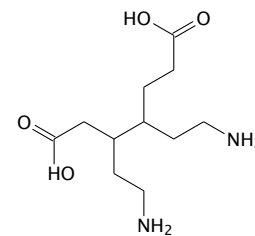
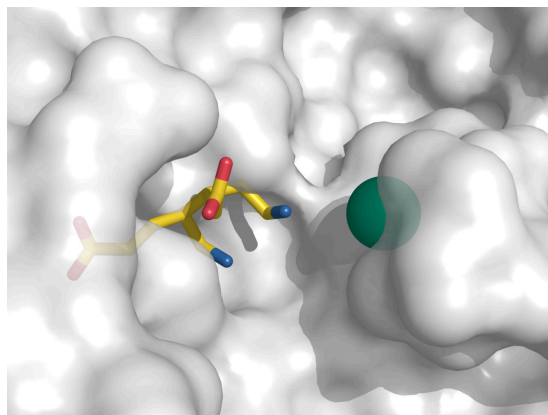

Notes: This pretty picture (rendered from [1pv8.pdb](#)) shows a model compound (structure on the right) inside the active site of porphobilinogen synthase, next to a zinc ion. It sheds little light on the reaction mechanism, or on the specific role of zinc. The only point I want to make here is that zinc is important for this enzyme. In lead intoxication, the zinc in porphobilinogen synthase is dislodged

by lead, which inhibits the enzyme and therefore the biosynthesis of heme and hemoglobin.



17.3 What is the effect of lead intoxication on heme biosynthesis, and what laboratory findings would you expect in patients suffering from it?

17.2.5 Porphobilinogen deaminase synthesizes hydroxymethylbilane

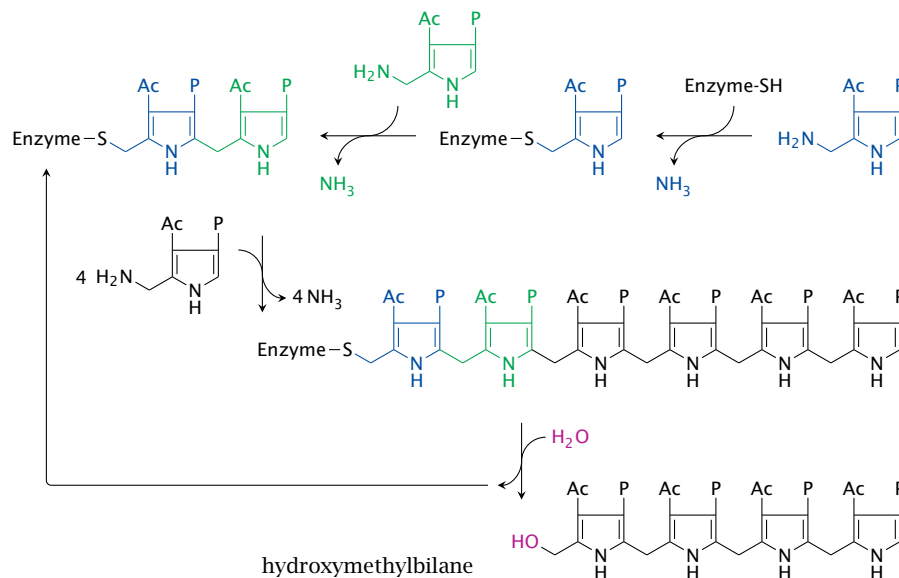

Notes: Porphobilinogen deaminase (or hydroxymethylbilane synthase) turns four molecules of porphobilinogen into one linear tetramer. The process involves the priming of the enzyme with two porphobilinogen subunits (shown in blue and green) which remain with the enzyme molecule throughout and serve as a prosthetic group. Another unusual feature of this enzyme is that it uses ammonia as a leaving group. (In this scheme, Ac and P denote the acetate and propionate groups that are part of the porphobilinogen molecule; compare slide 17.2.3.)

17.2.6 Synthesis of uro- and coporphyrinogen III

Notes: Hydroxymethylbilane, when left alone, cyclizes spontaneously, giving rise to a ring with fourfold rotational symmetry, with acetyl groups and propionyl groups alternating regularly around the perimeter of the molecule. The product of this spontaneous reaction is named uroporphyrinogen I.

Nature, however, prefers another isomer, namely, uroporphyrinogen III. To forestall its spontaneous cyclization into uroporphyrinogen I, hydroxymethylbilane is captured and processed directly by uroporphyrinogen III cosynthase, which forms a complex with porphyrinogen deaminase. The cosynthase creates the improbable-looking spiro intermediate shown here within brackets, which leads to the inverted orientation of the acetate and propionate side chains on the fourth ring in uroporphyrinogen III.

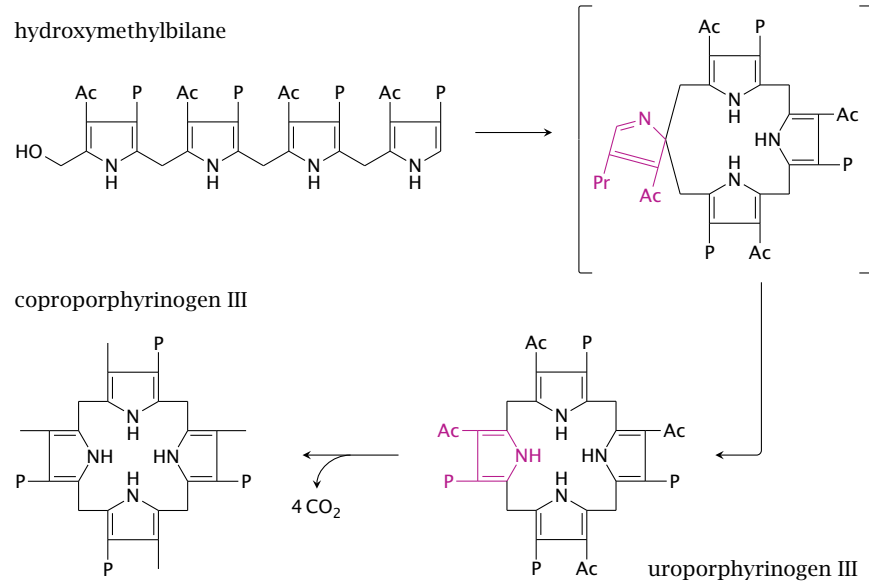

The next enzyme, uroporphyrinogen III decarboxylase, decarboxylates all four acetate groups to methyl groups. This gives coproporphyrinogen III, which again enters the mitochondria.

17.2.7 Final steps in heme synthesis

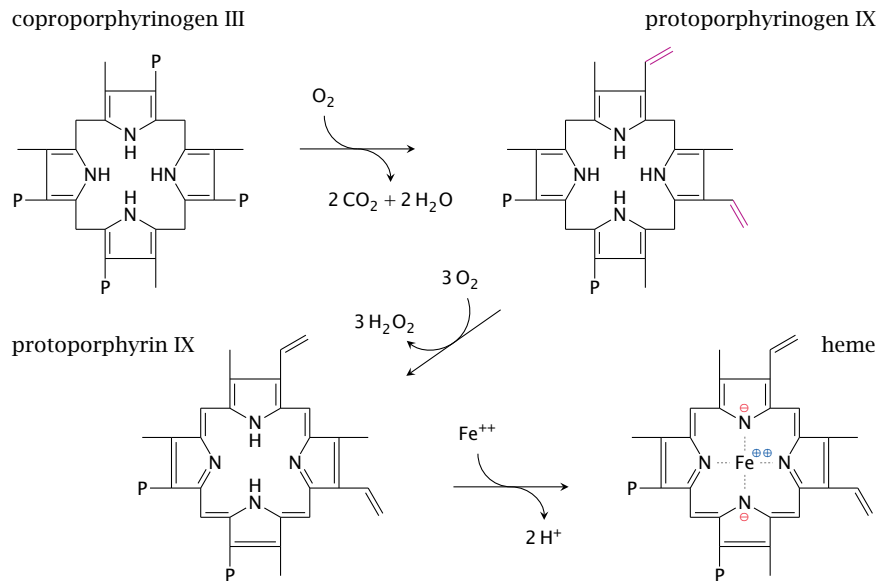

Notes: Oxidative decarboxylation converts two of the four propionate residues to vinyl groups, which produces protoporphyrinogen IX. Dehydrogenation to protoporphyrin IX is the final ring modification. Ferrochelatase then inserts the iron, which completes heme synthesis.

While the ferrochelatase reaction looks rather trivial and indeed can proceed with appreciable rate spontaneously, the enzyme is important: when it is absent,

protoporphyrin IX accumulates, which gives rise to a clinically manifest form of porphyria [120].

Heme retains the vinyl groups that were introduced at the stage of protoporphyrinogen IX. Addition of the sulfhydryl groups of cysteine side chains across these vinyl groups can produce covalent bonds between heme and some of its apoproteins. Such covalent attachment occurs for example in cytochrome C oxidase, but it does not happen in hemoglobin.



17.4 Explain the function of ferrochelatase.

17.3 Disruptions of heme synthesis

- hereditary enzyme defects (porphyrias)
- iron depletion
- vitamin B₆ deficiency—inhibition of aminolevulinate synthase
- lead poisoning—inhibition of porphobilinogen synthase

Notes: Hereditary deficiencies are known for each of the enzymes in the synthetic pathway. Clinical symptoms are due to both lack of heme and to the accumulation of biosynthetic intermediates. Heme exercises feedback inhibition on the first enzyme in the synthetic pathway, that is, δ -ALA synthase. A lack of heme therefore disinhibits this enzyme and amplifies the accumulation of intermediates upstream of the enzyme defect in question. Backed-up synthetic intermediates often undergo spontaneous conversion to aberrant products.

Inhibition of heme synthesis can also result from causes other than enzyme defects. The most common cause is iron depletion; another one is deficiency of vitamin B₆, which can result from malnutrition or, in inflammatory intestinal diseases, from malabsorption. Vitamin B₆ (pyridoxin) is the precursor of pyridoxal phosphate, the coenzyme in aminolevulinate synthase. Lead intoxication causes inhibition of porphobilinogen synthase (see slide 17.2.3); it is now less common than it used to be.

17.3.1 Disruption of heme synthesis microcytic, hypochromic anemia

Notes: Regardless of the underlying cause, the inhibition of heme synthesis will result in red blood cells that are smaller and contain less hemoglobin than normal ones. This condition is named *microcytic, hypochromic* anemia. The term “microcytic” refers to the reduced cell size, whereas “hypochromic” denotes the reduced intracellular hemoglobin concentration.



17.5 Explain the connection between vitamin B₆ deficiency and microcytic anemia.

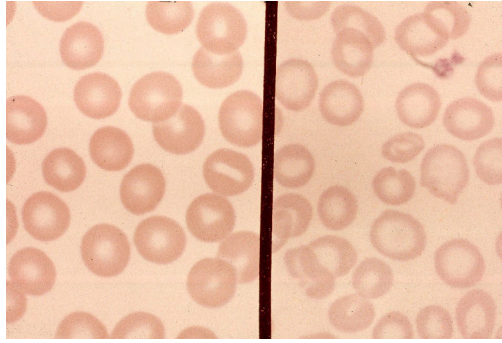

Normal red blood cells Microcytic anemia

17.3.2 Porphyria cutanea tarda (PCT) is caused by uroporphyrinogen decarboxylase deficiency

Notes: The accumulation of porphyrin precursors in various enzyme defects in porphyrin synthesis can cause photosensitization of the skin. The clinical picture can vary a bit, depending on the specific intermediate. As an example, we will consider the disease *porphyria cutanea tarda* (translated: chronic porphyria of the skin), which is the most common form of porphyria. Here, the deficient enzyme is uroporphyrinogen III decarboxylase (see slide 17.2.6).

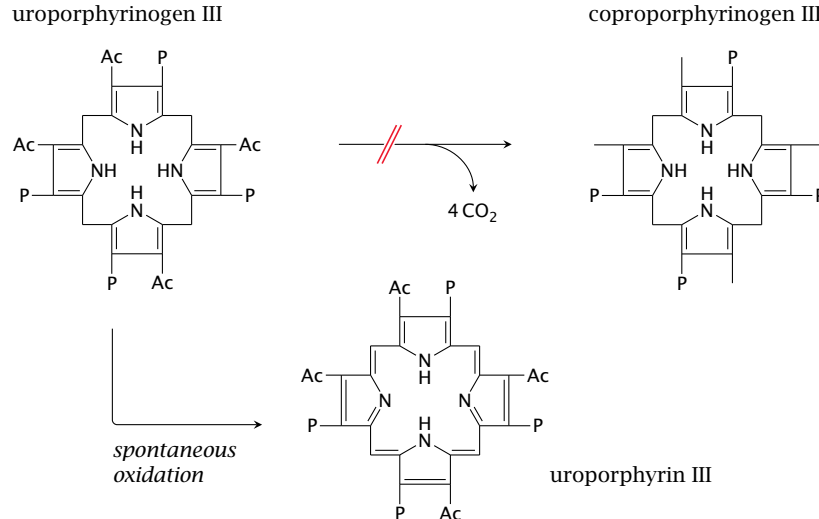

17.3.3 Laboratory and clinical findings in PCT

Notes: The accumulating uroporphyrinogen distributes throughout the body and becomes oxidized non-enzymatically to the non-physiological product uroporphyrin III. In the skin, uroporphyrin III can absorb photons and then react with molecular oxygen to produce reactive oxygen species; the latter inflict the skin

tissue damage that is illustrated in the slide. An important aspect of treatment is the protection of skin from direct sunlight.

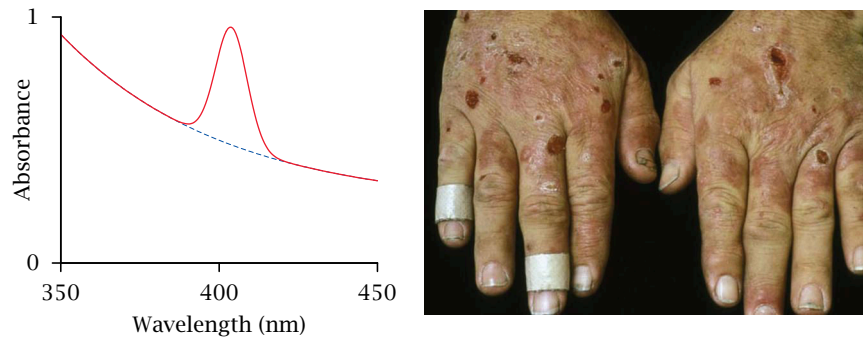

The absorbed wavelength range (or absorption spectrum) differs between the various porphyrins. Uroporphyrin III has an absorption peak at 405 nm, which is at the blue end of the visible spectrum; this peak is readily detectable in blood serum samples (left). The sun light is more intense in the visible range than in the UV range. Sun screen lotion, which is designed to absorb UV light but not visible light, will *not* prevent photosensitization by uroporphyrin III.

17.3.4 Causation of porphyria cutanea tarda

- hereditary—rare, autosomal dominant; enzyme defect is manifest in all tissues
- sporadic—exogenous, or related to genetic defect in iron uptake regulation
 - caused by alcohol, halogenated hydrocarbons, other toxic substances
 - enzyme activity lacking in the liver but not erythrocytes and other tissues—enzyme is functional but inhibited by interfering metabolites
- iron overload seems important in both hereditary and sporadic forms

Notes: Sporadic PCT is often associated with disturbances of iron homeostasis. Approximately two thirds of sporadic PCT patients carry a deficient allele for the iron regulator HFE. In homozygous form, this gene defect causes *hemochromatosis*, a disease that is characterized by severe iron overload. HFE knockout mice show increased intestinal expression and activity of iron uptake transporters.

Iron overload of the liver can also occur in chronic infections and in other chronic inflammatory diseases (see section 17.5). Blood letting—which depletes iron—is reportedly beneficial in PCT, regardless of the cause of the iron overload.



17.6 Explain the pathogenesis of the hereditary form of porphyria cutanea tarda.

17.3.5 Acute intermittent porphyria (AIP)

- deficiency of porphobilinogen deaminase, autosomal dominant
- excessive synthesis of δ -ALA in liver

- surplus porphobilinogen in urine—urine is colored red
- δ -ALA induces psychiatric symptoms—too often misdiagnosed and mistreated
- abdominal pain (neuropathic)
- episodes can be induced by drugs

Notes: The genetic defect in acute intermittent porphyria concerns the enzyme porphobilinogen deaminase. Both porphobilinogen and δ -ALA accumulate. Porphobilinogen is excreted with the urine and, through spontaneous oxidation, forms a characteristic red pigment. The more severe clinical symptoms, however, are due to accumulation of δ -aminolevulinate. This metabolite competitively inhibits the binding of γ -aminobutyrate (GABA), an inhibitory neurotransmitter, to its receptors [121], which likely causes both the psychiatric symptoms (agitation, confusion) and the neurological ones (nausea, abdominal pain) in AIP.

The dysregulation mainly affects heme synthesis in the liver. As the name of the disease suggests, it is not always manifest but only intermittently. Heme is the prosthetic group of cytochrome P450 enzymes, which are important in drug metabolism and are induced in the liver by various drugs (see slide 18.2.2). It appears that ALA synthase is induced along with the cytochrome P450 enzymes, and AIP attacks are often triggered or aggravated by the application of such drugs.

Specific drugs that induce cytochrome P450 and ALA synthase include barbituric acid derivatives and carbamazepine, which were, and occasionally still are, used in the treatment of psychiatric symptoms. Fatal outcomes have occurred when AIP patients were misdiagnosed and treated with barbituric acid derivatives.² One element of the correct therapy consists in the application of heme, which inhibits ALA synthase.



17.7 Explain the disease *acute intermittent porphyria* (AIP).

17.4 Heme degradation

Notes: Red blood cells have a regular lifespan of 120 days (although it can be considerably shorter in some diseases). At the end of this lifespan, they are captured and ingested by phagocytes in the spleen and the liver. When the globin protein is proteolytically degraded, heme is released. Heme itself undergoes degradation mostly in the liver. Ring cleavage by heme oxygenase produces biliverdin, which is in turn reduced to bilirubin. Some bilirubin is excreted into the bile as such; however, the greater share is first conjugated with glucuronic acid by UDP-glucuronosyltransferase, form 1A1, and excreted thereafter. The major transport protein responsible for excretion of the diglucuronide is an ABC transporter (ABCC2), the same one that also secretes bile acids (see slide 11.5.3).

In the large intestine, part of the conjugated bilirubin undergoes deconjugation by bacterial β -glucuronidases. In the anaerobic environment that prevails

²Generally speaking, any kind of psychiatric disturbance can potentially be due to organic causes, and therefore a thorough medical history and examination is necessary in each psychiatric patient. If you decide to become a psychiatrist, make it a point not to forget about your neurology and internal medicine.

inside the colon, the released bilirubin subsequently undergoes reduction, again by bacterial enzymes, to variously colored pigments that produce the stool color. Another reduction product, urobilinogen, is taken up and excreted with the urine, causing the yellow color of the latter.

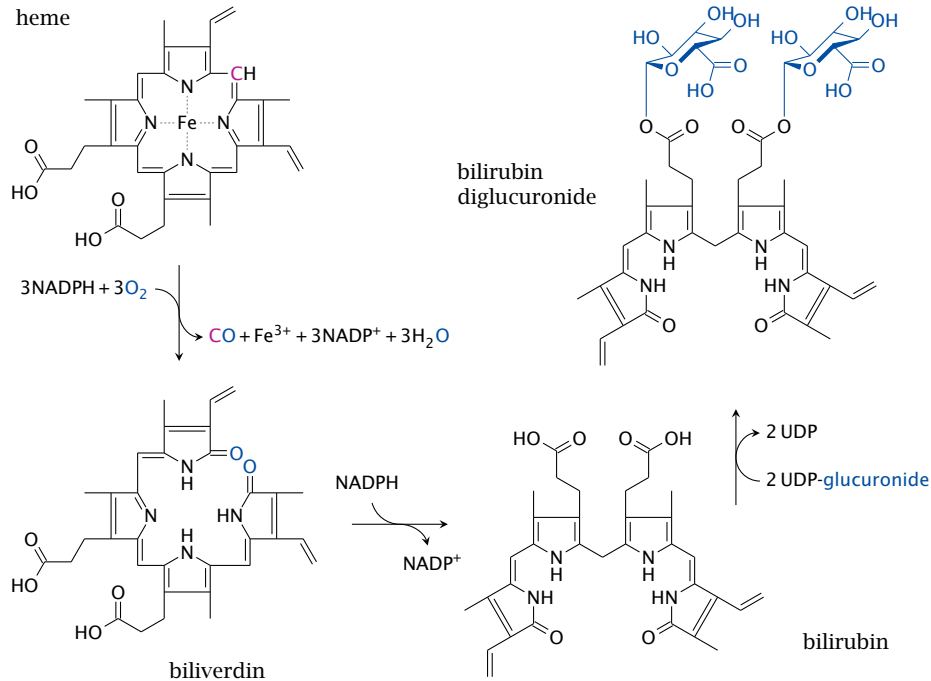

 **17.8** Explain how heme is degraded, and how the degradation product is disposed of.

17.4.1 Jaundice

Accumulation of bilirubin in the body. Causes:

- mechanically blocked excretion: bile duct blocked by bile stone or tumor
- increased production: hemolytic anemia (premature decay of red blood cells)
- decreased conjugation: enzyme defect, liver disease
- decreased excretion of conjugated heme: deficiency of ABCC2 transporter (Dubin-Johnson syndrome)

Notes: Some fairly simple clues can narrow down the cause of jaundice in a given patient. If excretion of bilirubin is blocked, the pigments derived from it will be absent, and the stool will have a grayish color.

Hemolysis consists in the accelerated decay of red blood cells; it may result from biochemical causes such as glucose-6-phosphate dehydrogenase deficiency (see section 9.4), or from immunological ones such as Rhesus incompatibility. In hemolysis, the serum level of unconjugated bilirubin will be more strongly increased than that of the diglucuronide. On the other hand, when the flow of the bile is backed up, the conjugated bilirubin will spill back into the serum and will be increased.

Liver diseases can affect synthesis, conjugation and biliary secretion of bilirubin in various degrees, and either form of bilirubin can be more strongly increased than the other.

17.4.2 Enzyme defects in bilirubin conjugation by UDP-glucuronosyltransferase

- transient, usually mild: neonatal jaundice
- genetic, mild: Gilbert syndrome—asymptomatic jaundice
- genetic, severe, rare: Crigler-Najjar syndrome

Notes: Neonatal jaundice is a normal event that is caused by a transiently low level of UDP-glucuronosyltransferase 1A1.³ In most cases, it does not cause any problems and simply goes away within two weeks after birth, as the level of enzyme activity increases. If the serum level of bilirubin gets too high, however, it may accumulate in the brain and cause neurological problems (see next slide). To prevent this, newborns can be treated with *phototherapy* (see slide 17.4.4).

Crigler-Najjar syndrome is due to the genetic deficiency of UDP-glucuronosyltransferase 1A1. It initially becomes manifest as neonatal jaundice; however, since the gene defect is permanent, the situation doesn't improve with time. As in many other gene defects, there are variants with total or partial disruption of enzyme activity. Milder cases are classified as Gilbert's syndrome; the boundary between Gilbert's and Crigler-Najjar syndrome will be somewhat arbitrary. When residual enzyme activity is present, it is possible to increase it with drugs such as phenobarbital that transcriptionally induce it.

As in neonatal jaundice, phototherapy is also used in Crigler-Najjar syndrome, but its efficiency decreases with time, since the growth of the body reduces its surface to volume ratio, and therefore a diminishing fraction of the bilirubin in the body can be reached by illumination. The disease is best treated with liver transplants, as the transplanted liver will not be affected by the underlying gene defect and be able to conjugate and excrete bilirubin.

17.4.3 Bilirubin encephalopathy (“kernicterus”)

Notes: This slide shows a brain section from a patient with severe bilirubin encephalopathy. The yellow color in the deeper structures of the forebrain—the so-called basal ganglia—is due to bilirubin accumulation. Through an unknown biochemical mechanism, bilirubin causes damage to the basal ganglia, which results in motor dysfunction and other neurological symptoms.

³Prior to birth, the bilirubin formed by the fetus is eliminated via the placenta and therefore does not accumulate. The same applies to the toxic metabolites that accumulate in phenylketonuria (see slide 12.5.1) and several other hereditary metabolic diseases, which therefore become manifest only after birth.

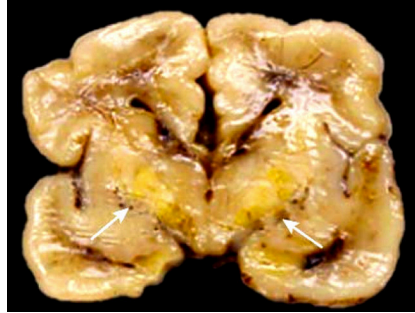

17.4.4 Photoisomerization products of bilirubin

Notes: In phototherapy, bilirubin absorbs photons and subsequently undergoes *cis-trans* isomerization across the two remaining double bonds between the pyrrole rings of the bilirubin molecule, as well as ring formation [122]. This slide shows some of the photochemical reaction products. The 4Z,15Z isomer of bilirubin (top left) is the one that is produced directly by biliverdin reductase, and which is eliminated very slowly in the unconjugated form. The other isomers are eliminated more rapidly; the fastest rate of elimination is observed with lumirubin (cyclobilirubin).

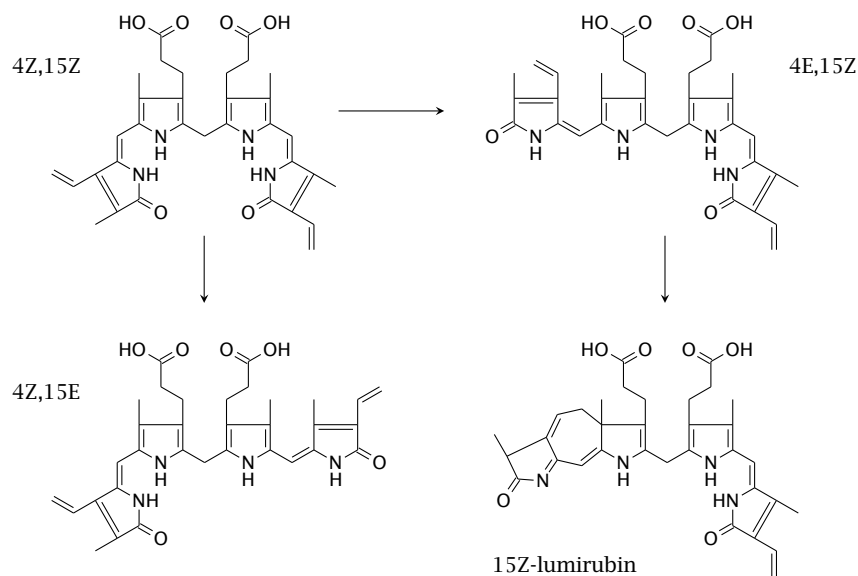

While the absorption maximum of bilirubin is in the blue wavelength band, green light reportedly produces lumirubin more efficiently, and it also induces less cytotoxic byproducts in cell culture models [123]. It seems, however, that blue lamps are still more widely used in practice, and the literature does not make mention of significant side effects of blue light, even in the long-term treatment of Crigler-Najjar patients [124].



17.9 Explain the rationale and application of phototherapy in newborns.

17.4.5 Sn-mesoporphyrin, an inhibitor of heme oxygenase

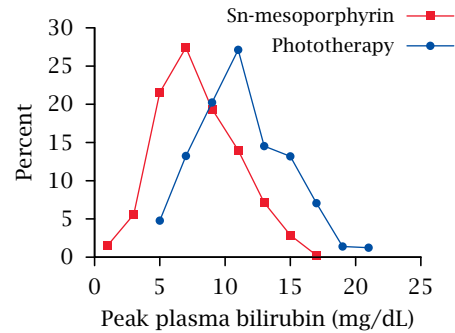
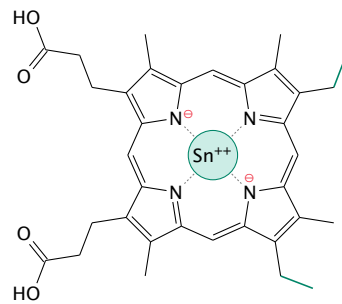

Notes: The inhibition of heme oxygenase with Sn-mesoporphyrin has been used successfully in clinical studies to treat neonatal jaundice. The study summarized in this slide examined the effectiveness of Sn-mesoporphyrin in the treatment of newborns with glucose-6-phosphate dehydrogenase deficiency (see slide 9.4). In this condition, the lifespan of red blood cells is diminished, which increases the rate of heme degradation; newborns therefore are at an increased risk of severe jaundice.

Remarkably, a single injection of the drug was sufficient to reduce the peak levels of bilirubin to a greater extent than the reference treatment (phototherapy). It should be noted that both forms of treatment sufficed to keep the peak bilirubin levels below 25 mg/dL, which is considered sufficient to avoid damage to the brain. Phototherapy currently remains the standard treatment in clinical practice. Figure prepared from original data in [125].

17.4.6 Is CO a signaling molecule, like NO?

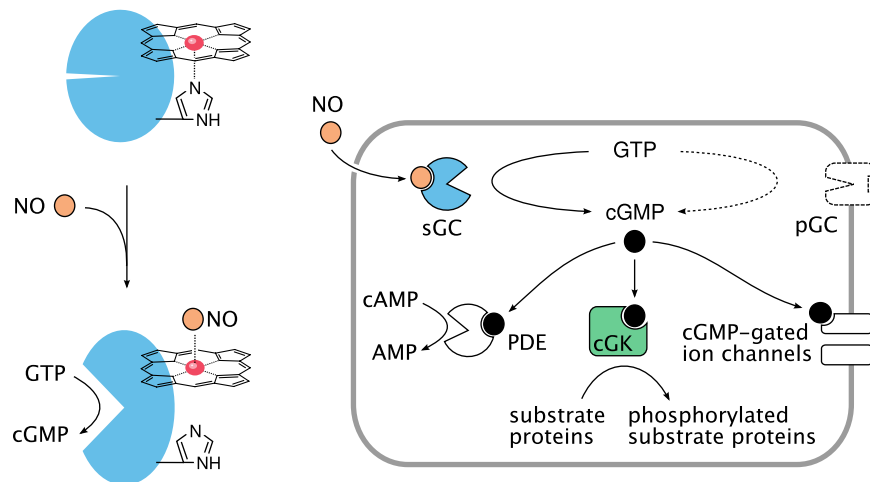

Notes: Nitric oxide is an important signaling molecule. As a small molecule, it can easily diffuse out of one cell and into another. Inside the target cell, it binds to soluble guanylate cyclase (sGC). Interestingly, the NO-binding site on sGC is a

heme molecule. Binding of NO to one face of the heme releases a histidine side chain on the other, which causes a conformational change and activation of the sGC molecule.

In vitro experiments show that CO can also bind and activate sGC. It has therefore been proposed that heme oxygenase, which produces CO, has a regulatory role in addition to its metabolic one. However, while this idea has been around for awhile, I have not come across solid evidence that supports a significant signaling role of CO in vivo.

17.5 Iron uptake, transport and storage

- uptake in the small intestine: Fe^{2+} —free or bound to heme
- transient storage as ferritin inside the intestinal epithelia
- transport in the blood: Fe^{3+} —bound to transferrin with very high affinity
- cellular uptake: endocytosis of transferrin, release of iron in acidic endosome
- storage: intracellular ferritin particles
- depletion: scaled-off cells, blood loss, breast milk

Notes: Only ferrous iron (Fe^{2+}) can be taken up from the small intestine, so that is what we give to patients. Still, during passage through the intestine, much of the ferrous iron is oxidized to the ferric form (Fe^{3+}), which means that intestinal uptake is not very efficient.

The very high affinity of transferrin to iron means that there is practically no free iron in the blood serum. Bacteria, like human cells, require iron for growth; therefore, keeping free iron very low is an important non-specific immune mechanism. Many pathogenic bacteria produce their own high-affinity iron-binding molecules (siderophores) to acquire iron within this iron-depleted environment.

In chronic infections, free iron in the serum is reduced even below the normal low value, presumably in an attempt by the immune system to starve microbial pathogens of iron. The same also happens in tumor patients and non-infectious inflammatory diseases such as rheumatism, since the immune system is not smart enough to tell the difference between these and infections. As a result, an anemia develops in which the blood cells look just like the ones in true iron depletion. However, in contrast to the latter, the level of cellular storage iron will be *increased* in this case—iron is not lacking, it is just being kept out of circulation. If iron sequestration is observed in a patient, one must search for the underlying disease that causes it.

Loss of iron occurs with cells being scaled off from the skin and intestinal epithelia, with blood loss (menstruation, blood donations), with diaplacental transfer to a growing fetus, and with breast milk. Mothers who have many children within a relatively short period of time have a good chance to incur iron depletion, so this is something to watch out for as a physician.

17.5.1 Structure of ferritin

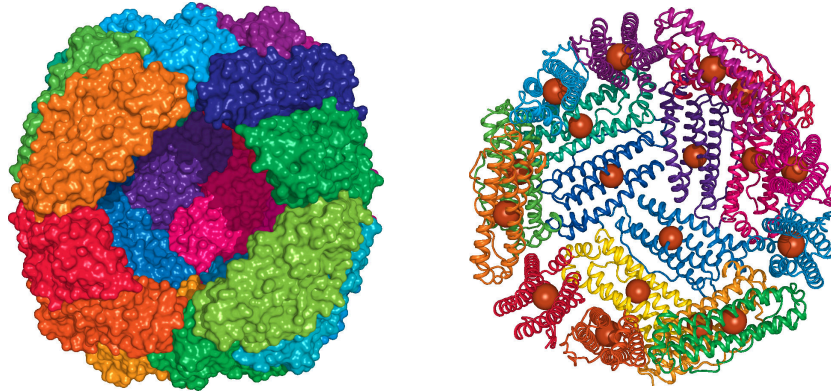

Notes: Ferritin is hollow protein particle that consists of 24 identical subunits. Up to ~4,500 iron ions can be stored inside the particle, in the form of FeOOH.

On the left, two neighboring subunits have been removed from the front of the sphere, and we are peeking into the interior of the shell, which in vivo would be packed with iron. On the right, some more subunits have been removed, and the iron ions actually contained in the crystal structure—just one per subunit—are shown as spheres. Can you figure out why the crystallographers did not try to obtain a structure of the fully loaded particle? Rendered from [1fha.pdb](#).

17.5.2 Ferritin in the small intestine regulates iron uptake

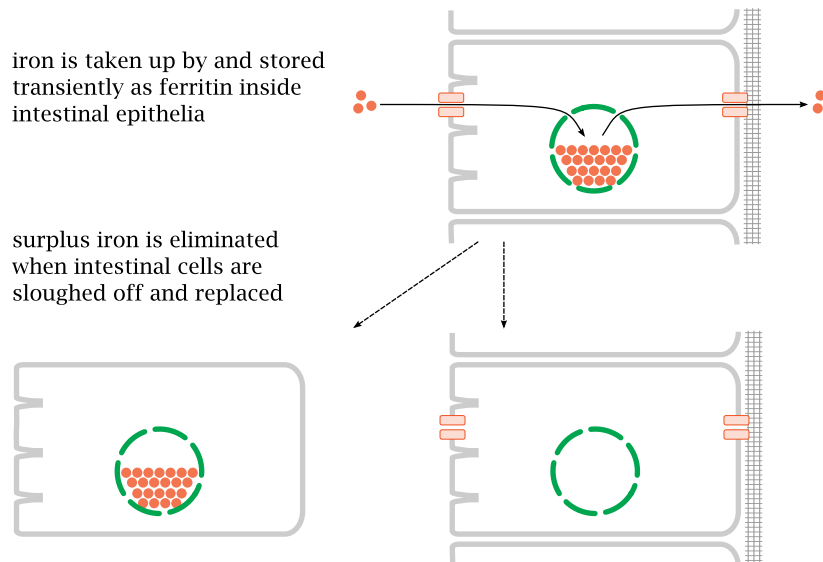

17.5.3 Hemosiderin in liver tissue

Notes: In diseases that cause iron overload, the storage capacity of ferritin will be exceeded. Excess iron will then precipitate around the ferritin particles and cause them to aggregate. These iron-rich aggregates are called *hemosiderin*.

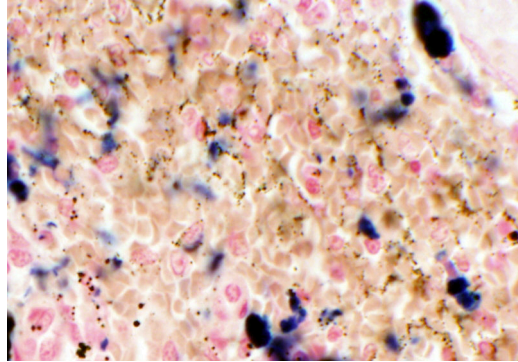

Iron overload can occur as a result of multiple blood transfusions, or of genetic defects that interfere with iron transport. An example is a defect of *ceruloplasmin*, a copper-containing serum protein that oxidizes Fe^{2+} to Fe^{3+} .

In the figure, the brown stipples represent the hemosiderin. The dark blue blotches are out of focus and are just precipitated dye particles, that is, artifacts; this tends to happen if dye solutions stand around on the shelf for too long.



17.10 Describe the structure and function of ferritin.

17.6 Answers to practice questions

17.1: 1. Transport (hemoglobin) and intermediate storage (myoglobin) of oxygen, 2. Enzyme catalysis (cytochrome P450 enzymes, cyclooxygenases), 3. Electron transport (respiratory chain), 4. Allosteric regulation (binding of NO to guanylate cyclase).

17.2: The synthesis of δ -aminolevulinate from succinyl-CoA and glycine by δ -aminolevulinate synthase. It is inhibited by heme.

17.3: Lead inhibits porphobilinogen synthase and therefore heme biosynthesis. This results in hypochromic anemia, that is, less hemoglobin per erythrocyte, and increased blood levels of δ -aminolevulinate, the substrate of porphobilinogen synthase.

17.4: Ferrochelatase catalyzes the last step in heme synthesis. It inserts an iron ion into the protoporphyrin IX ring.

17.5: Microcytic anemia results from the inhibition of heme synthesis. Vitamin B₆ is the precursor of pyridoxal phosphate, which is the coenzyme of ALA synthase. A reduced activity of ALA synthase will reduce the rate of heme synthesis.

17.6: The enzyme defect concerns uroporphyrinogen III decarboxylase. Uroporphyrinogen III accumulates and is non-enzymatically converted to uroporphyrin III, which distributes throughout the body. In the skin, it mediates the photochemical formation of reactive oxygen species, which cause skin damage.

17.7: AIP is due to the excessive production of δ -aminolevulinic acid (ALA) and the following metabolite, porphobilinogen. The disease is due to mutations in porphobilinogen

deaminase. Its episodes can be triggered by drugs that induce ALA synthase. Excretion of porphobilinogen causes the urine to turn red. Accumulation of ALA itself causes neurological and psychiatric symptoms due to competitive inhibition of GABA receptors in the central nervous system.

17.8: Heme oxygenase breaks the porphyrin ring and releases CO. The product, biliverdin, is then reduced to bilirubin. The two carboxylic acid moieties of bilirubin are conjugated with glucuronic acid by UDP-glucuronosyltransferase, and bilirubin-diglucuronide is secreted with the bile.

17.9: In newborns, the enzyme activity of UDP-glucuronosyltransferase 1A1 is low, so that unconjugated bilirubin accumulates. This poses a risk of neurological damage.

The unconjugated bilirubin distributes throughout the body, including the skin, and in the latter location is accessible to light. Absorption of blue or green light promotes the formation of bilirubin isomers that are more readily excreted even without conjugation. Phototherapy therefore lowers the level of bilirubin.

17.10: Ferritin is the major intracellular storage medium for iron. Each ferritin particle is a large protein complex with 24 identical subunits. It forms a hollow shell that can store up to 4,500 iron ions.

Chapter 18

Metabolism of drugs and xenobiotics

18.1 Functional significance

- inactivation and facilitated elimination of drugs and xenobiotics
- activation of *prodrugs*
- formation of *active metabolites* with similar or novel activity
- detoxification of toxic xenobiotics
- *toxification* of non-toxic xenobiotics

Notes: Drugs can be considered a subset of *xenobiotics*, that is, natural compounds of exogenous origin that may find their way into the human body. Other important classes of xenobiotics are potentially toxic plant alkaloids or fungal toxins. The metabolic pathways that have evolved to deal with these natural xenobiotics are active on many synthetic drugs also.

In most cases, metabolic transformation of a drug results in its inactivation and accelerated elimination from the body. However, other outcomes are possible, as will be discussed below.

18.1.1 Enzyme specificity in drug metabolism

- key problem: a limited number of enzymes must cope with an unlimited number of substrates
- many drug-metabolizing enzymes have fairly broad specificities
- enzyme specificities overlap—many drugs give rise to multiple metabolites

Notes: The human body contains several dozen enzymes that are primarily dedicated to the metabolism of xenobiotics. Many of these enzymes can modify a large number of structurally diverse drugs and xenobiotics.

18.1.2 Example: metabolism of phenobarbital

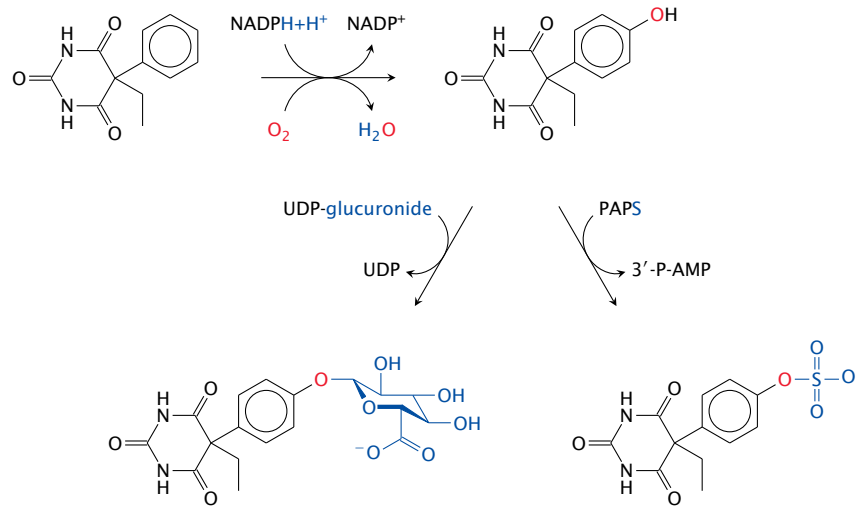

Notes: Phenobarbital, a barbituric acid derivative with both sleep-inducing and anti-epileptic activity, illustrates both the significance and the workings of drug metabolism. The drug molecule itself is quite hydrophobic. This causes the drug to distribute into fat tissue. The amount that remains in the plasma is partially bound to plasma proteins. Therefore, only a small fraction of the drug is, at any time, found freely dissolved in the blood plasma and thus amenable to filtration and excretion in the kidneys, or to biliary secretion in the liver. Elimination of the unmodified drug is thus very slow, and the lion's share of the drug is excreted after enzymatic conjugation.

Phenobarbital as such is not amenable to conjugation reactions. This problem is overcome by a cytochrome P450 enzyme, which introduces a hydroxyl group into the molecule. This hydroxyl group is then conjugated with either glucuronic acid or sulfate. Both of these metabolites are sufficiently polar and are effectively excreted through the kidneys.

18.1.3 Drug metabolism facilitates drug elimination

Notes: Drug metabolism works hand in hand with excretion. The key organs in drug metabolism and excretion are the small intestine, the liver, and the kidneys.

Drug-modifying enzymes are highly expressed in the small intestine and the liver. The reactions catalyzed by these enzymes are classified into phase I and phase II reactions. Broadly speaking, a phase I reaction introduces a functional group into a substrate that enables its subsequent conjugation in a phase II reaction. Conjugation, in most cases, increases the polarity of the substrate, rendering it more amenable to secretion into the bile or to excretion in the urine. The two stages of phenobarbital metabolism depicted in the preceding slide exemplify phase I and phase II transformations, respectively.

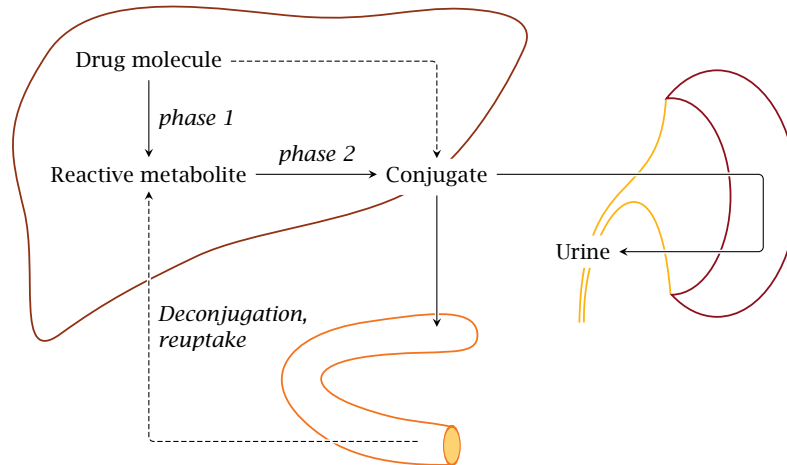

Biliary secretion of drugs or drug conjugates requires active transport, as does tubular secretion into the nascent urine. Some of the transport proteins involved recognize the groups that were conjugated to the drug molecules, for example, glucuronic acid or glutathione. Excretion by active transport is sometimes referred to as phase III of elimination.

Note also that drugs that are taken orally will encounter drug-metabolizing enzymes in the small intestine and the liver before they even enter the systemic circulation. In many cases, a large fraction of the drug molecules is already modified and inactivated at this early stage; this fraction is referred to as the drug's *first pass effect*.



18.1 Explain the physiological significance of drug metabolism, and the distinction between phase I and phase II metabolism.

18.2 Cytochrome P450 enzymes

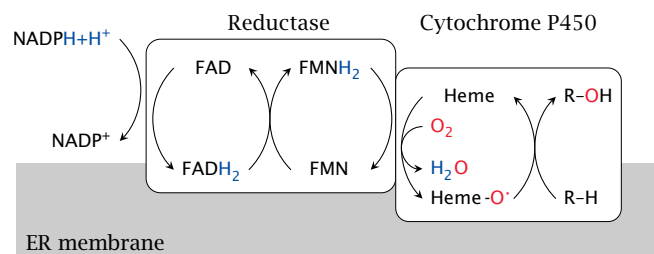

Notes: Cytochrome P450 is a large family of enzymes that are found in both prokaryotic and eukaryotic organisms. In mammalian cells, they are found in both the ER and the mitochondria, and they function in various biosynthetic pathways, such as cholesterol and steroid hormone synthesis. Several dozen CYP450 (CYP) isoforms are involved in drug metabolism; they are the most important group of enzymes in phase I metabolism. These isoforms are found mostly in the ER.

The reactions catalyzed by CYP enzymes start with the abstraction of hydrogen from NADPH by cytochrome P450 reductase, an auxiliary enzyme. The hydrogen is used by CYP to reduce one of the two atoms of molecular oxygen to water. The

other oxygen atom is retained in a highly reactive form, which is then used to force one or the other kind of reaction on a substrate.

18.2.1 Reactions catalyzed by cytochrome P450

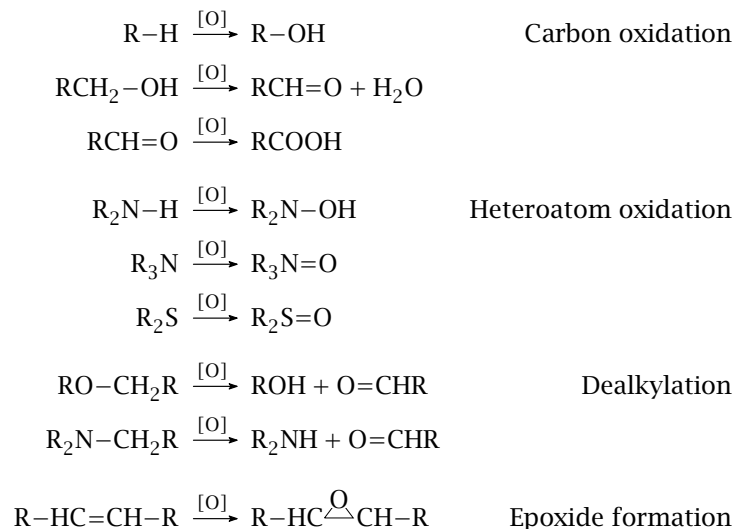

Notes: Apart from aromatic or aliphatic hydroxylation, CYP enzymes can also bring about several other types of reactions. Oxidation can occur once or repeatedly; for example, hydroxyl groups can be further oxidized to aldehydes and carboxylic acids. Oxidation is not confined to carbons but can also affect heteroatoms. Dealkylation is a powerful way to break up and inactivate drug molecules.

Amine oxidation, aldehyde formation, and epoxide formation yield reactive groups that may subsequently cause toxic effects. Therefore, while drug metabolism often abolishes toxicity, sometimes it can actually create it.



18.2 Explain the mode of action of cytochrome P450 enzymes, and name some typical reactions that they perform on drug molecules.

18.2.2 Transcriptional induction of CYP450 3A4

Notes: Considering that there are several dozen different CYP enzymes in human cells, it is remarkable that a single isoform, CYP3A4, is involved in the metabolism of some 50% of all clinically prescribed drugs. Like several other isoforms, CYP3A4 is *inducible*, that is, its rate of gene transcription is increased by certain drugs.

With CYP3A4, the nuclear hormone receptor that mediates induction is the pregnane X receptor (PXR). When a suitable drug binds to this receptor, it translocates from the cytosol to the nucleus and binds to its cognate regulatory DNA sequences, referred to as xenobiotic response elements (XRE); this results in increased transcription of genes in the vicinity. The PXR responds to a particularly wide variety of drugs, which in part accounts for the prominent role of CYP3A4 in drug metabolism.

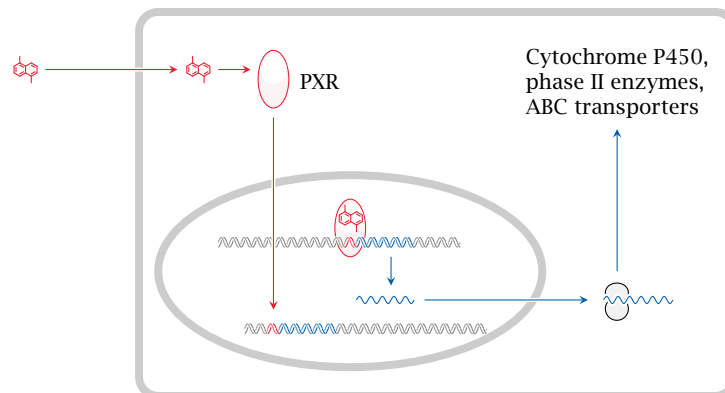

Enzyme induction often leads to accelerated metabolism of multiple drugs, not just the inducing drug itself. Examples are rifampicin, an antibiotic used in tuberculosis, as well as phenytoin and phenobarbital, which are used as anti-epileptic agents. These drugs all induce accelerated inactivation of each other. Furthermore, they also accelerate the metabolism of contraceptives and render these drugs ineffective.

Together with cytochrome P450 enzymes, conjugating enzymes and active transporters that function in drug excretion are also induced. CYP enzymes contain heme; the first and rate-limiting step of heme synthesis is catalyzed by δ -aminolevulinic acid synthase (see slide 17.2.2). This enzyme is also induced, and through this mechanism certain drugs, including the examples listed above, can exacerbate acute intermittent porphyria (see slide 17.3.5).

 **18.3** Explain the role of enzyme induction in drug metabolism.

18.2.3 Structure of erythromycin bound to cytochrome P450 3A4

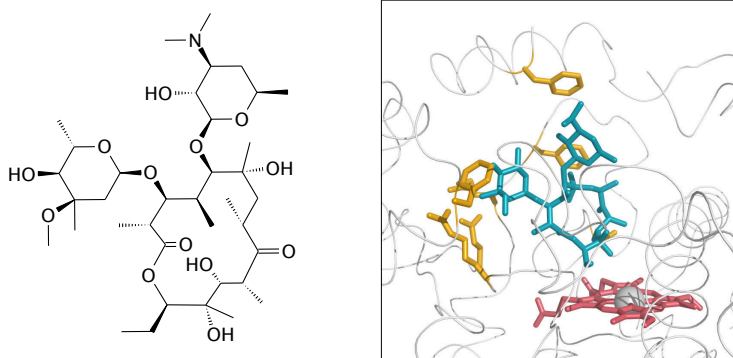

Notes: Another reason of CYP3A4's prominent role in drug metabolism is its own ability to accommodate a wide variety of substrates within its active site. This slide and the next one illustrate two examples. The drugs, erythromycin in this slide and ketoconazole in the next one, are shown in blue or green. The heme of CYP3A4 is shown in red, and several amino acid side chains that interact with the drug molecules are shown in yellow. Note the differences in protein conformation and the interacting residues between both slides.

ibility of the enzyme molecule that allows it to accommodate, and therefore to metabolize, a large number different substrates.¹



18.4 Some cytochrome P450 enzymes, for example CYP3A4, act upon an unusually wide range of different substrates. How can this be explained?

18.2.6 Formation of active metabolites by CYP450 enzymes

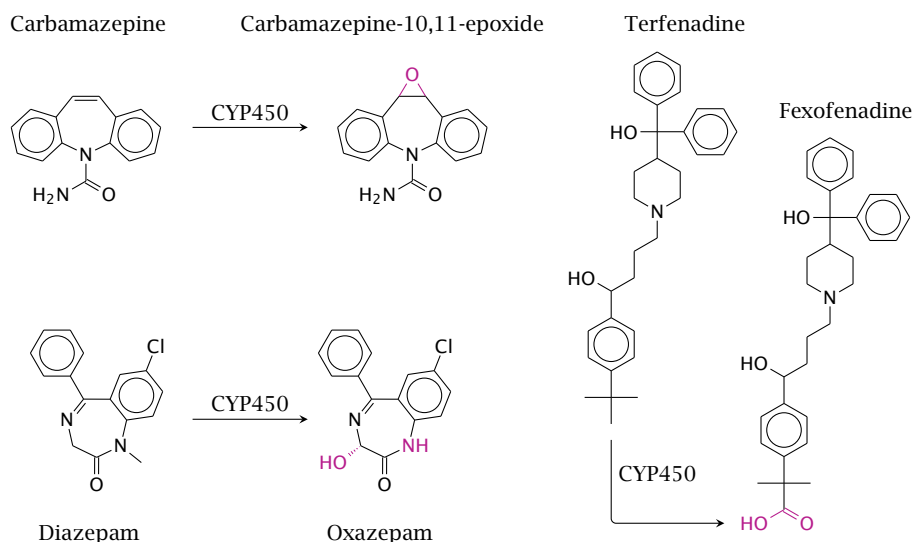

Notes: While drug metabolism often results in inactivation, metabolites may retain pharmacological activity, or sometimes even acquire novel ones. For example, two CYP-mediated reactions convert diazepam to oxazepam, which retains the pharmacological activity of the parent compound.

Some active metabolites, including oxazepam and fexofenadine, have become drugs in their own right. Since these molecules are already prepared for conjugation, they are usually more rapidly eliminated than the parent compounds. In the case of oxazepam, this is an advantage when the intention is to induce sleep, since most of the drug will have been excreted the next day. In contrast, diazepam works better in the treatment of epilepsy, where a more stable and steady level of drug activity is desired.

With all examples shown in this slide, both the parent molecules and the metabolites have pharmacological activity. For various applications, drugs have been designed that actually require metabolic conversion to become active; such molecules are referred to as *prodrugs*. Some organic nitrates, for example nitroglycerin, are metabolized by cytochrome P450 enzymes to release nitric oxide as the active principle. Other examples of prodrugs are sulfonamides (see slide 15.3) as well as tenofovir and cidofovir (slide 16.9.14).



18.5 Explain the concept of active drug metabolites.

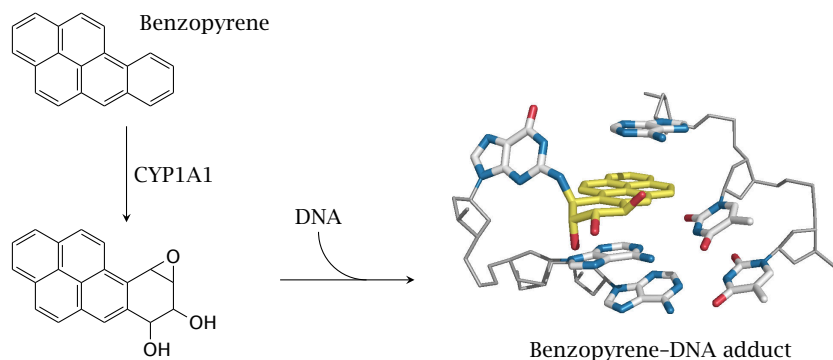

¹In the molecular structures, there also are some discontinuities. These represent conformationally flexible segments of the polypeptide chain that did not give rise to distinct diffraction signals.

18.2.7 Benzopyrene as an example of harmful metabolism of xenobiotics



Notes: Benzopyrene and related compounds activate the *aromatic hydrocarbon receptor* (AHR), a nuclear hormone receptor that is functionally similar to PXR but instead of CYP3A4 induces CYP1A1. The reaction of this enzyme with aromatic hydrocarbons tends to produce epoxides, which react easily with nucleophiles. Epoxides of polycyclic aromatic molecules are particularly harmful, since they can intercalate into DNA. The epoxide can then react covalently with the DNA and cause mutagenic damage.

Polycyclic aromatic hydrocarbons such as benzopyrene arise from incomplete combustion of organic matter, such as in car exhaust fumes or cigarette smoke. Their metabolic conversion to epoxides and subsequent reaction with DNA is the major mechanism of carcinogenesis in smokers.

-  **18.6** Explain the role of metabolism in the carcinogenic effect of polycyclic aromatic hydrocarbons such as benzopyrene.
-  **18.7** If a molecule of benzopyrene has been metabolically activated to an epoxide, what will be the mechanism of reaction with nucleic acids?

18.3 Phase II reactions

18.3.1 Summary of phase II reactions

Notes: This list is sorted roughly according to decreasing importance. Glucuronidation is the most common reaction, followed by sulfation; both were illustrated in slide 18.1.2. Some more reactions will be illustrated below.

None of the cosubstrates and reaction mechanisms employed in conjugation are used exclusively in drug metabolism. UDP-glucuronide and PAPS are also used in the synthesis of proteoglycans, glutathione occurs in many redox reactions and in the synthesis of leukotriene mediators, and amino acid conjugation is used with bile acids. Some enzymes may act upon both endogenous metabolites and xenobiotics; examples are catechol-*O*-methyltransferase, which apart from drugs also conjugates epinephrine and norepinephrine, and glycine-*N*-acyltransferase, which attaches glycine to both drugs and to cholic acid.

Enzymes	Cosubstrates	Functional groups
UDP-glucuronosyl-transferases	UDP-glucuronide	-OH, -NH ₂
sulfotransferases	PAPS	-OH, -NH ₂
glutathione-S-transferases	glutathione	epoxy groups, double bonds
acetyltransferases	acetyl-CoA	-OH, -NH ₂
methyltransferases	SAM	-OH, -NH ₂ , -SH
epoxide hydrolase	H ₂ O	epoxide groups
aminoacyltransferases	amino acids	-COOH

18.3.2 Detoxification of benzopyrene epoxide derivatives by epoxide hydrolase or glutathione-S-transferase

Notes: Fortunately for smokers, not all aromatic epoxide molecules will end up reacting with DNA. One major detoxification pathway is the reaction with glutathione, which is facilitated by glutathione-S-transferase (left). Epoxide hydrolase (right) also contributes to the detoxification.

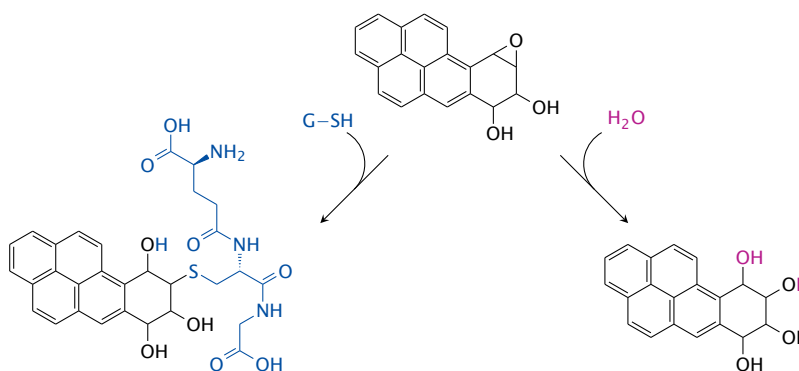

The epoxide hydrolase reaction occurs after a phase I reaction, so therefore could be considered part of phase II. On the other hand, it does not result in conjugation, and it thus might be considered not to be part of phase II. So, which phase does it belong to?

This question is purely one of definition and therefore irrelevant. It is only mentioned to illustrate that the distinction between phase I and II reactions, while useful, has its limitations.

18.3.3 Metabolism of acetaminophen

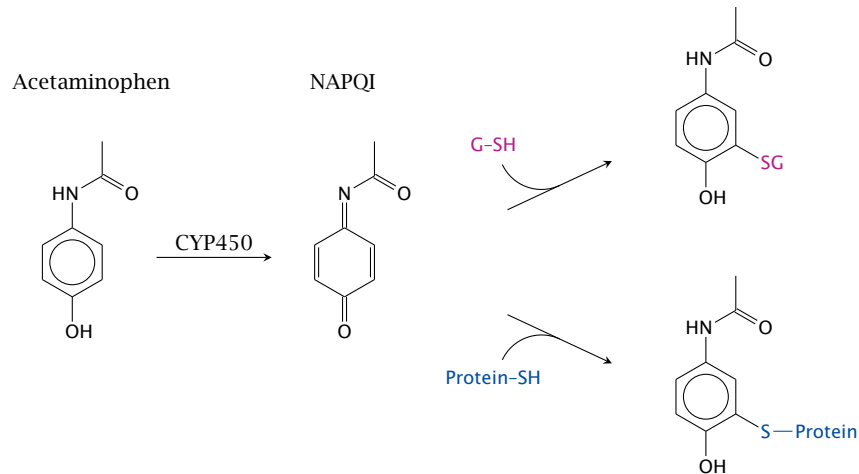

Notes: Acetaminophen also undergoes successive phase I and phase II reactions. The initial CYP-catalyzed reaction yields N-acetyl-*p*-benzoquinone imine (NAPQI). This molecule is also quite reactive towards nucleophiles, particularly sulfhydryl groups. Glutathione is the most abundant intracellular thiol, with a free concentration of ~5 mM, and while supplies last will neutralize most NAPQI. However, once glutathione has been depleted, NAPQI will start reacting with cellular macromolecules and cause cytotoxicity. This mostly affects the liver, since it has the highest activity of cytochrome P450 enzymes and therefore will produce the most NAPQI.

Acetaminophen is well tolerated when applied at dosages that will not deplete glutathione. However, it turns toxic rapidly once the safe dosage limit is exceeded.



18.8 Explain the role of metabolism in the toxicity of acetaminophen.

18.3.4 Morphine skips phase I and is conjugated directly

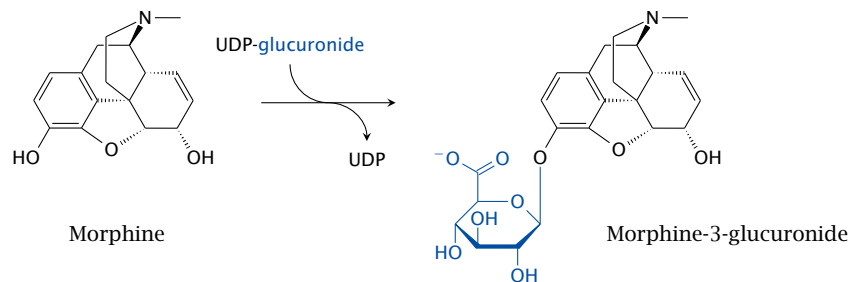

Notes: Phase I reactions are not necessary if a drug molecule already contains functional groups suitable for conjugation. An example is morphine, which has two hydroxyl groups. The conjugation of either, or both, with glucuronic acid is sufficient for excretion. Interestingly, one of the two single glucuronides—the one *not* shown here—retains pharmacological activity.

N-demethylation of morphine by cytochrome P450 can occur but does not significantly affect excretion.

18.3.5 Acetylation of INH by N-acetyltransferase 2 (NAT 2)

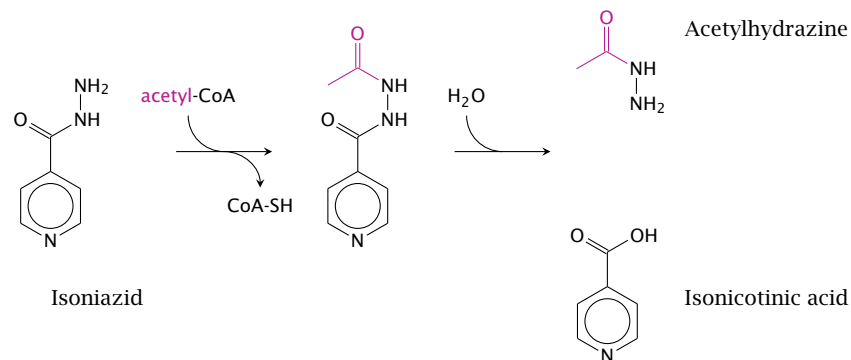

Notes: The metabolism of isoniazid (isonicotinic acid hydrazide, INH; a tuberculostatic agent) also starts with a phase II reaction. N-acetyltransferase 2 (NAT2) acetylates the hydrazide group. The product can decay, and the acetyl-hydrazide can transfer its acetyl group to other nucleophiles in the cell.

18.3.6 Bimodal distribution of INH acetylation speed

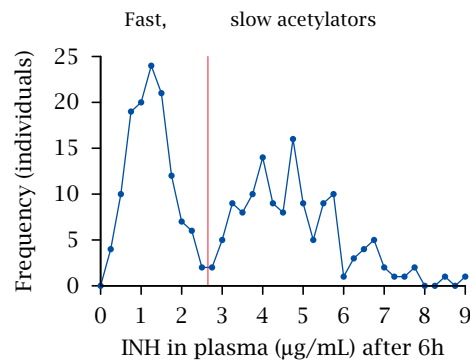

Notes: The depicted experiment measured the speed of acetylation. A fixed test dosage was applied at $t=0$, and the remaining plasma concentration was determined 6 hours later. There clearly are two separate peaks, which represent the fast and slow acetylators, respectively. Among Caucasians, about 50% express an inactive NAT2 allele, which causes the slow-acetylator phenotype. The percentage of slow acetylators is lower among Asians (but was higher in a small study on Kenyans [127]; I don't know how representative that study is).

Apart from isoniazid, the NAT2 enzyme and its polymorphism also affects the inactivation rates of some other drugs, such as procainamide and hydralazine, which in slow acetylators are more likely to cause toxicity. A role of this polymorphism has also been reported in the susceptibility to bladder cancer caused by aromatic amines, which in Europeans was found to correlate with slow acetylator

status. Surprisingly, this correlation was not observed in Chinese [128]. The reason for this discrepancy is unknown.



18.9 What are fast and slow acetylators?

18.3.7 Amino acid conjugation: Glutamine conjugation of phenylacetate

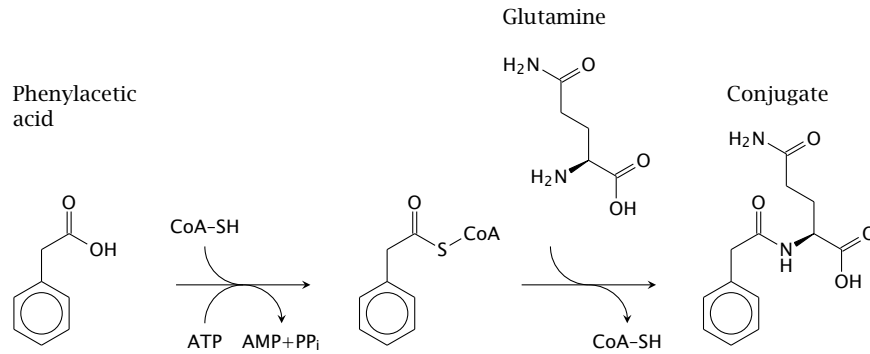

Notes: Amino acid conjugation is limited to xenobiotics that are carboxylic acids, which are first activated to coenzyme A-thioesters and then linked to an amino acid by an amide bond. The amino acid may be glutamine (as shown), glycine, or taurine. The latter two amino acids are also used in the synthesis of the conjugated bile acids taurocholate and glycocholate (see slide 11.5.1).

The pathway can be put to use in the alternate pathway therapy of urea cycle enzyme defects (see slide 12.3.10). In this application, the usual physiological role of amino acid conjugation is turned on its head. Normally, amino acids are expended in order to eliminate unwanted organic acids; in contrast, here we supply innocuous organic acids, the amino acid conjugates of which then become vehicles for the elimination of surplus nitrogen. Brilliant!

An organic acid commonly used in alternate pathway therapy is phenylbutanoic acid, which first undergoes β -oxidation to phenylacetic acid (the substrate shown here) before conjugation to glutamine and excretion. It may be combined with benzoate, which undergoes conjugation with glycine and therefore recruits another enzyme and another pool of nitrogen.



18.10 Name the major types of reactions, enzymes and cosubstrates in phase II drug metabolism.

18.4 Reductive drug metabolism

Multiple enzymes:

- methemoglobin reductase (diaphorase)
- cytochrome P450 reductase
- thioredoxin
- bacterial metabolism
- ...

Notes: While cytochrome P450 enzymes play the most important role in phase I metabolism, some drugs are actually reduced rather than oxidized at this stage. The enzymes involved are a somewhat heterogeneous bunch and primarily serve in roles other than the metabolism of xenobiotics.

18.5 Anti-tumor drugs that are preferentially activated in tumor cells

This section, after some introduction, examines two antitumor prodrugs that attempt to exploit metabolic activation to selectively target tumor cells.

18.5.1 DNA damage triggers programmed cell death

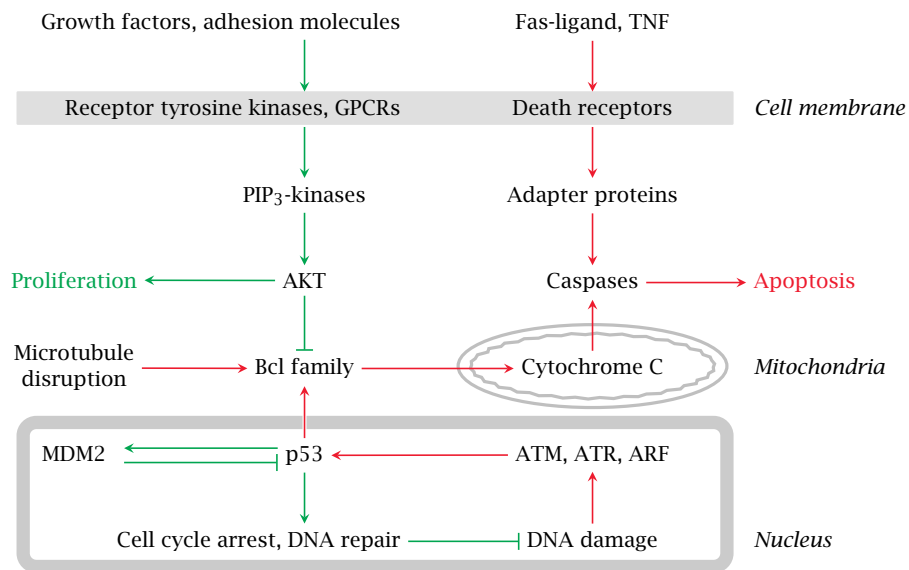

Notes: Programmed cell death, or *apoptosis*, is a protective mechanism that inhibits the proliferation of genetically damaged cells. DNA damage is detected by so-called checkpoint proteins during various stages of the cell cycle. Extracellular signals can promote or inhibit apoptosis. Cancer cells are often more susceptible to apoptotic stimuli than normal cells are. This is exploited by the use of DNA-damaging, cytotoxic drugs in cancer chemotherapy.

18.5.2 Mechlorethamine, a DNA-alkylating drug

Notes: Many anticancer drugs are DNA-alkylating agents; mechlorethamine is a straightforward example. Bifunctional DNA-alkylating agents such as this one have much higher antitumor activity than monofunctional ones, since they can crosslink the two DNA strands; this makes semi-conservative DNA repair impossible.

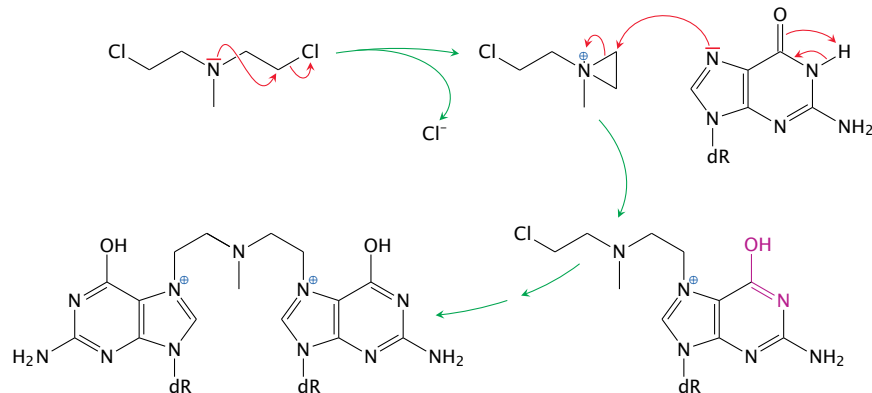

18.5.3 CB 1954, an experimental antitumor drug that is activated by nitro group reduction and acetylation

Notes: The experimental drug CB 1954 is, in its original form, a monovalent alkylating agent; the alkylating group is the aziridine group (the three-membered ring at the top). It is activated to a bifunctional agent in two steps. Diaphorase (methemoglobin reductase) reduces the nitro group to a hydroxylamine, which is then acetylated by an acetyltransferase to form a reactive acetoxy group [129].

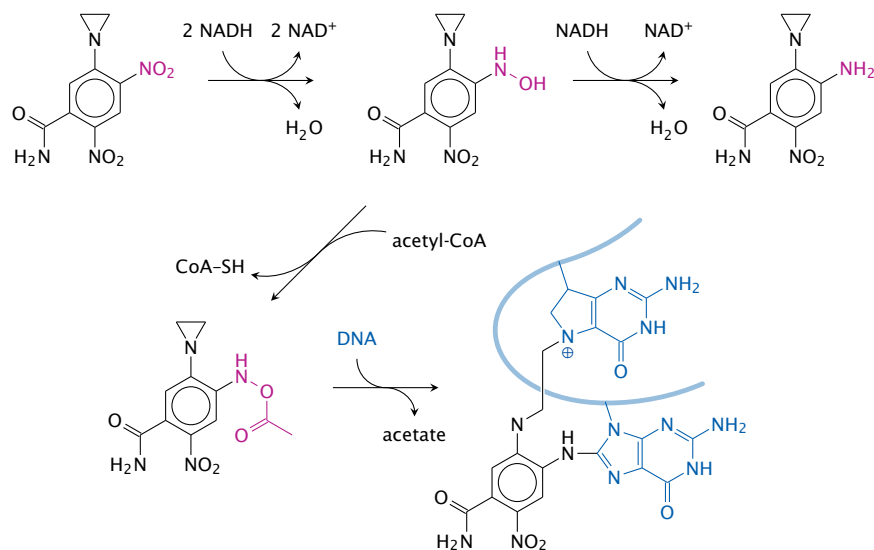

For reasons that are not well understood, the environment inside tumor cells is often more reducing than in nontumorous cells, which will result in preferential activation of this drug inside tumor cells. CB 1954 is somewhat of a perennial “experimental” drug, which probably means that it is not very compelling in clinical use. However, several established anticancer drugs such as doxorubicin and bleomycin also require reductive activation [130], which may enhance their selectivity for cancer cells.

18.5.4 Canfosfamide, an antitumor drug that targets alkylant-resistant tumor cells

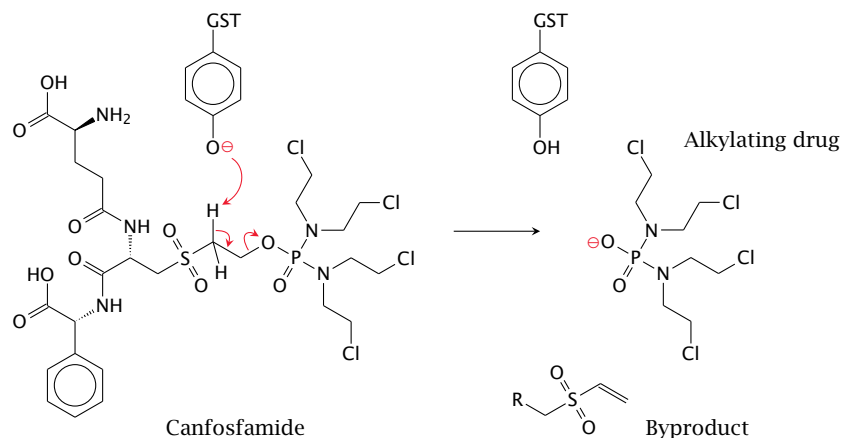

Notes: Glutathione conjugation can inactivate alkylating agents, for example ones with epoxide groups (slide 18.3.2) or anticancer drugs such as mechlorethamine (slide 18.5.2). Accordingly, tumor cells may develop resistance to alkylating antitumor drugs by increasing their expression of glutathione-S-transferase.

The antitumor agent canfosfamide targets such cells, since it has been designed to *require* activation by glutathione-S-transferase (GST; the catalytic residue is a tyrosine). This drug is currently in clinical trials.

18.6 Answers to practice questions

18.1: Drug metabolism usually inactivates drugs and facilitates their elimination. The highest activities of drug-metabolizing enzymes are found in the small intestine and the liver; therefore, orally applied drug molecules often are inactivated even before they reach the systemic circulation.

Drug molecules often undergo several successive reactions. Phase I reactions introduce reactive groups into drug molecules that are often inert otherwise; such reactions are most often carried out by cytochrome P450 enzymes.

Phase II reactions are conjugations. They often operate on functional groups on that were introduced into the drug molecule in a phase I reaction. The groups that are attached to the drug molecules are usually polar. Increased polarity promotes excretion of the drug.

18.2: Cytochrome P450 enzymes use two electrons from NADPH to asymmetrically reduce O_2 , such that one oxygen atom is disposed of as water and the other one is retained at the heme, which forms the prosthetic group of the enzyme. This reactive oxygen atom is then used to force a reaction on the substrate. Reactions include oxidation of aromatic or aliphatic carbon atoms, nitrogen or sulfur atoms, dealkylation of heteroatoms, and epoxidation of double bonds.

18.3: Drug molecules can bind and activate nuclear hormone receptors, which then bind to specific sequence motifs in the genome. This results in the increased expression of cytochrome P450 enzymes, as well as phase II enzymes and transporters. This results in the accelerated inactivation and elimination of the inducing drug molecules, and possibly of others that may be applied simultaneously.

The pregnane X receptor, or PXR, has particularly broad ligand specificity. PXR mediates transcriptional activation of CYP3A4, which in turn participates in the metabolism of ~50% of all drugs.

18.4: 1. CYP3A4 and several other enzymes have flexible active sites that can accommodate a large variety of substrates. 2. Cytochrome P450 enzymes transfer oxygen in a highly activated form that can react with a wide range of different functional groups. Therefore, it is not necessary for the substrate to interact or cooperate with the enzyme in a highly specific manner.

18.5: Metabolic transformation of drug molecules does not always lead to inactivation, and where it does not, the products are referred to as active metabolites. Some drugs even *require* metabolic transformation for activity; these are referred to as prodrugs.

18.6: Polycyclic aromatic hydrocarbons are hydrophobic and planar molecules and, as such, tend to intercalate into DNA. Since the unmodified aromatic compounds are chemically inert, intercalation as such does little damage. However, introduction of epoxide bonds by cytochrome P450 (in particular type 1A1) makes the aromatic hydrocarbons reactive and enables them to covalently react with DNA. During DNA replication, such covalent adducts cause mutations and potentially cancer.

Epoxides can be detoxified by phase II enzymes, in particular glutathione-S-transferase and epoxide hydrolase.

18.7: After intercalation, a nucleophile in the DNA, typically a nitrogen, will perform nucleophilic attack on one of the carbons in the epoxide. The reaction is analogous to the one shown in slide 18.3.2, in which the sulfur of glutathione acts as the nucleophile.

18.8: Acetaminophen is converted by cytochrome P450 to a reactive intermediate (N-acetyl-*p*-benzoquinone imine, NAPQI) that reacts with glutathione. Toxicity ensues when glutathione is depleted, leaving the cell unprotected from excess NAPQI and reactive oxygen species.

18.9: Fast and slow acetylators are individuals that carry different alleles for the enzyme *N*-acetyltransferase 2 (NAT2). In slow acetylators, the enzyme is inactive. This causes a slower rate of acetylation and inactivation of INH and several other drugs, particularly aromatic amines.

18.10:

1. Glucuronic acid conjugation (UDP-glucuronosyltransferases, UDP-glucuronide)
2. Sulfate conjugation (Sulfotransferases, Phosphoadenosine-phosphosulfate)
3. Acetylation (*N*- and *O*-acetyltransferases, acetyl-CoA)
4. Methylation (Methyltransferases, *S*-adenosylmethionine)
5. Amino acid conjugation (glutamine, glycine, taurine)

Chapter 19

Enzyme and gene therapy of enzyme defects

19.1 General considerations

- How many organs are affected by the enzyme defect: One organ, a few, or all organs?
- How severe is the defect?
- Can the defect be adequately controlled by conventional treatment?

Notes: While some enzymes, such as pyruvate dehydrogenase, are expressed and required in almost all cells, others are expressed exclusively or preferentially in selected organs. For example, UDP-glucuronosyltransferases are expressed mostly in the liver, and enzyme defects accordingly affect this organ the most.

The clinical severity of enzyme defects ranges from benign to fatal. A fairly benign defect is the Gilbert syndrome, in which the rate of bilirubin glucuronidation is reduced. This condition requires nothing more than caution in the selection and dosage of drugs when treating other diseases. On the other hand, untreated adenosine deaminase deficiency is fatal (see sections 16.5 above and 19.2 below). Obviously, aggressive therapeutic strategies such as organ transplants or gene therapy are warranted only with severe defects.

19.1.1 Conventional therapeutic strategies

- diets
- drugs
- organ transplants

Notes: Diets can be used in many enzyme defects, and if effective, they are certainly preferable. An example is the fructose- and sucrose-free diet in fructose intolerance, which effectively prevents the deleterious depletion of free phosphate and of ATP in this disease (see slide 4.2.2).

Drugs are useful in several hereditary enzyme defects, but usually in a limited way. We have already discussed the use of NTCB in tyrosinemia (slide 12.5.4) and of organic acids in urea cycle defects (slide 12.3.10); a few more examples are discussed below. Organ transplants are useful in those diseases that primarily affect a single organ, typically the bone marrow or the liver.



19.1 Explain how organ transplants can be used to treat genetic enzyme defects.

19.1.2 Therapeutic strategies based on molecular biology

Correction of ...

- DNA: gene therapy
- mRNA: suppression of mutant stop codons with drugs
- protein: enzyme substitution

Notes: Enzyme defects are in principle the most logical and suitable targets for gene therapy. A key advantage of gene therapy is its long-lasting effect—at least in principle, the treatment maybe be effective for life. However, in most enzyme defects, gene therapy is still at the experimental stage, and it has not yet become the standard therapy in any specific disease.

Enzyme substitution therapy is more widely used. Since the enzyme molecules have a limited half-life, the enzyme has to be applied regularly, often in weekly or bi-weekly intervals. While this is costly and somewhat inconvenient, it has the advantage that the therapy can simply be discontinued in case of untoward reactions, which would obviously not be feasible with gene therapy.

Correction at the mRNA level through suppression of stop codons—also referred to as translational antitermination—is confined to a few specific examples; obviously, not all gene defects that inactivate an enzyme involve mutant stop codons.

19.1.3 Translational antitermination with PTC124 (ataluren)

Notes: Many genetic diseases are caused by point mutations that inactivate some important enzyme or other protein. Very often, such inactivating mutations are heterogeneous; deletions, insertions, frameshift mutations, and point mutations may all give rise to the same clinical picture. The only group of patients that may benefit from translational antitermination are those who carry a point mutation that creates a premature stop codon in an otherwise intact open reading frame. In this situation, it may be possible to restore expression of a functional protein by promoting translational *miscoding*, that is, incorporation of some amino acid or other vis-a-vis the mutant stop codon, which then enables the ribosome to keep translating right through to the regular stop codon.¹

¹If you are wondering now how this can be done without suppressing the orderly termination of translation at the regular stop codon, I have no answer for you, but nevertheless commend you for

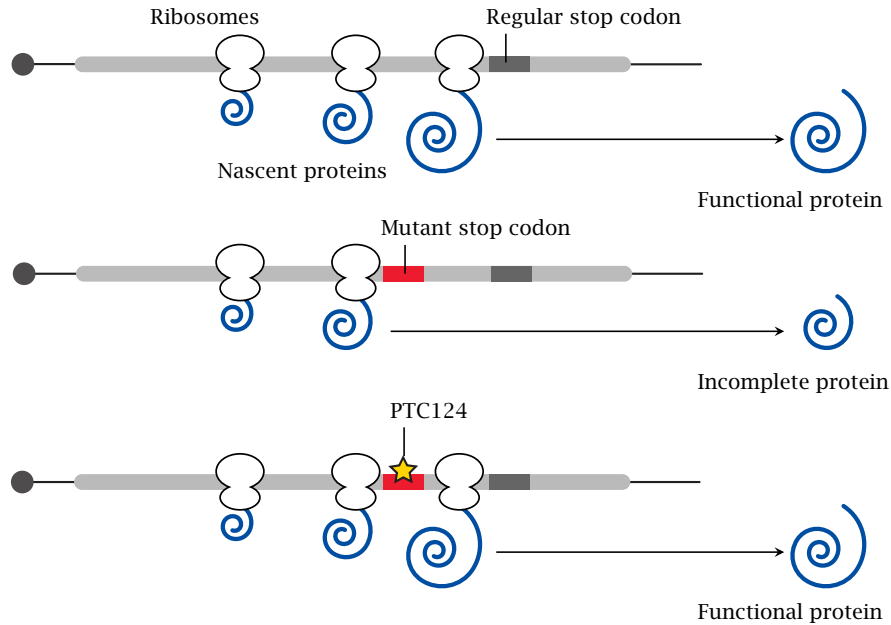

An experimental drug that promotes translational suppression of mutant premature stop codons is PTC124 [131], also named ataluren. Its biochemical mode of action is not known exactly; however, it is noteworthy that several aminoglycoside antibiotics have similar effects, and some are also being investigated for similar therapeutic uses [132]. Aminoglycosides bind to ribosomes and, at sub-inhibitory concentrations, reduce translational fidelity; it may be that ataluren does the same.

19.1.4 Ataluren in cystic fibrosis

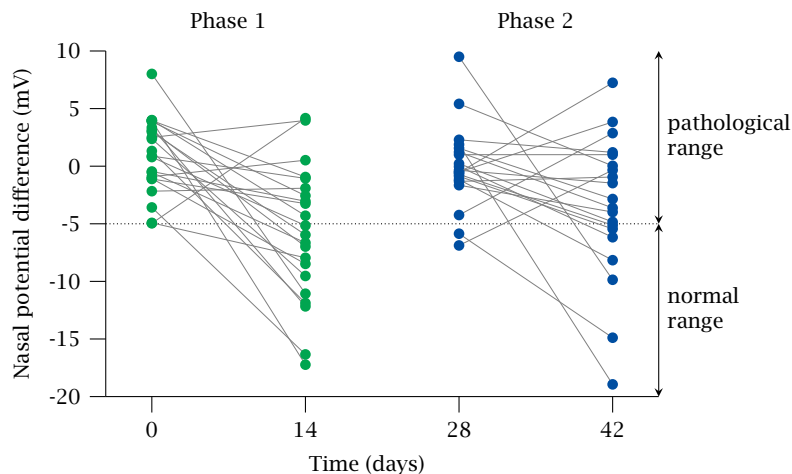

paying attention. In case you were *not* wondering about this, you were probably not really studying but just cramming for the exam.

Translational miscoding will not usually restore the original amino acid that was present before the stop mutation occurred. Therefore, a further requirement is that the amino acid residue in question is not critical for protein activity.

Notes: The effectiveness of ataluren in various genetic diseases has been tested in clinical pilot studies. This slide illustrates one such study, which was performed on cystic fibrosis patients. This disease is caused by a deficiency in an ABC transporter that exports chloride ions from cells, which impedes the secretion of fluid in all kinds of exocrine glands. Multiple organs are functionally impaired, but the most serious consequences arise from the buildup of viscous mucus in the lungs, which facilitates chronic bacterial infections and ultimately leads to organ destruction.

In a sizable minority of all cystic fibrosis patients, the gene defect consists in a premature stop codon, and in this group translational antitermination is a plausible therapeutic strategy. The data illustrate the response to the drug among such patients, during two successive phases of treatment. The effect of the drug was measured as the electric potential difference that exists across the nasal mucous membrane; this potential is increased when the chloride export by the epithelial cells is reduced. Lines connect measurements on individual patients before and after each course of treatment. Evidently, most patients experienced a reduction in potential, that is, an increase in chloride export. Figure prepared from original data in [133].

19.1.5 Technical considerations for gene therapy

1. gene transfer *in vivo* versus *in vitro*
2. transfer method: viral vectors vs naked DNA
3. location of transferred gene: chromosomal versus episomal
4. expression of transferred genes: transient versus permanent
5. immune reactions to vector (particularly where repeated application is required)

Notes: The basic idea of gene therapy is to introduce a functional copy of the defective gene into the affected body cells, so that they can start making their own functional protein. In many cases, we would like to deliver the gene to only those tissues or organs that actually require the deficient gene, and to do so with high efficiency. This has in practice been difficult. However, in the example discussed below, namely, adenosine deaminase deficiency, this can be achieved by first isolating the target cells—in this case, the bone marrow stem cells—and then introducing the gene into them *in vitro*.

Transfer of naked DNA into cells can be achieved by electroporation or using cationic lipids. These methods are only applicable *in vitro*. Viral vectors, which are packaged into the viral capsids and coats proteins of some pathogenic viruses and, like regular viruses, enter body cells and deliver their nucleic acids with high efficiency, can be used both *in vitro* and *in vivo*.

One way to achieve persistence and permanent expression of the transferred gene is to stably integrate it into the genome of the recipient cell. This is most efficiently achieved with retrovirus-derived vectors, since chromosomal integration is part of the life retroviral cycle. However, a caveat is that the location of insertion

within the genome cannot be reliably controlled. Integration may occur in the vicinity of some cancer-related gene, causing its transcriptional up- or downregulation. Cases of leukemia have been induced in experiments both in humans and animals.

Adenoviruses are double-stranded DNA viruses that replicate without integration into the host cell genome. Accordingly, adenovirus-derived vectors will not insert into the genome, which is safer. However, such *episomal* replication will typically not be as long-lasting and stable as that of the retroviral vectors. If repeated application of the vector is required, this will likely work only a limited number of times, since, like the wild-type viruses, the coated vector particles are immunogenic, and antibodies will interfere with their entry into cells.

Viruses of the Herpes family remain episomal yet are persistent, which is in principle a very favorable combination. While their very large genome—Herpes viruses are second only to Pox viruses in this regard—makes their use as vectors technically challenging, they might well emerge as the vectors of choice in the long run. An overview of the state of the art concerning viral vectors can be found in [134].



19.2 Explain the advantages and disadvantages of retroviral vectors for gene therapy.

19.2 Adenosine deaminase deficiency

Adenosine deaminase (ADA) catalyzes the first step in the degradation of adenosine and deoxyadenosine (see section 16.5). Deoxyadenosine accumulates and is phosphorylated by salvage kinases, which yields dATP. Accumulating dATP exercises feedback inhibition on ribonucleotide reductase [135], which is required in the *de novo* synthesis of all deoxynucleotides (see slide 16.8).

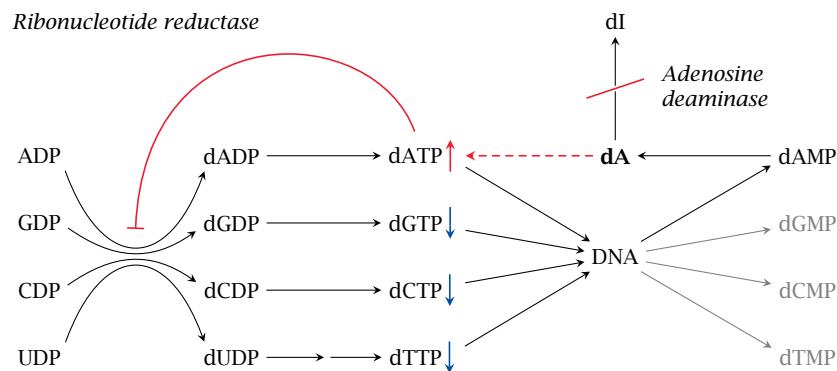

The resulting imbalance in the supply of deoxyribonucleotides—dATP is up, whereas all others are down—constrains the rate of DNA replication.

Interference with DNA replication promotes apoptosis (see slide 18.5.1). While the enzyme defect is manifest in all cells, apoptosis actually occurs only in T-lymphocytes, which quite generally are much more prone to it than other cells. The decisive role of apoptosis in this condition is evident from the dependence of T-cell degeneration on p53 [136], a nuclear protein that is a key switch of apoptosis.

The apoptotic demise of the T-cells becomes manifest in early infancy in the form of a severe combined immunodeficiency (SCID). The deficiency is referred to as *combined* because it affects both humoral immunity, that is, antibody formation, and cellular immunity, which is mediated by killer T-cells. Without treatment, the children die after a few years; aggressive treatment is therefore justified.

19.2.1 Conventional therapy of ADA deficiency: Allogenic bone marrow transplant

- currently the standard treatment
- side effects and complications can be severe
- requires compatible donor

Notes: Lymphocytes are the only cells adversely affected by ADA deficiency. These cells originate in the bone marrow; therefore, replacement of the patient's bone marrow with that of a healthy donor is an effective and curative treatment.

Allogenic bone marrow transplantation is a risky procedure and truly an ordeal. It requires an immunologically compatible donor. The best odds for finding one is within the family; the chance of a match between siblings is one in four. Failing that, a donor may be found anywhere in the world. As ever more people are getting typed for histocompatibility antigen profile for the sake of some transplant or other, the odds of finding a random match are improving.

However, except for identical twins,² no donor will ever be 100% compatible, and there remains a risk of immunological complications. In addition, during the first few weeks after transplantation, the patient has essentially no immune system, and the risk of severe, even fatal infections is high. In short, less risky and less torturous alternatives are desirable.

19.2.2 Experimental drug treatment of ADA deficiency

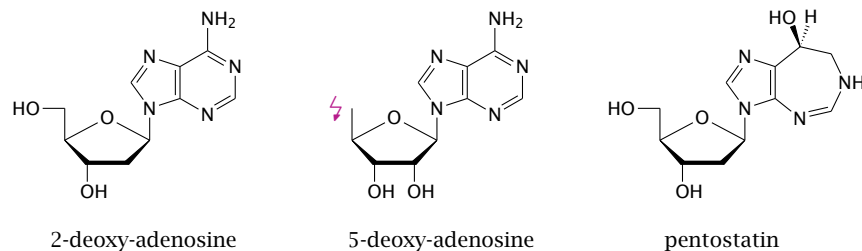

Notes: The experimental drug 5-deoxyadenosine—2'-deoxyadenosine is shown just for comparison—inhibits deoxyadenosine kinase, which catalyzes the phosphorylation of deoxyadenosine to dAMP. Considering that the phosphorylation

²An identical twin would not be helpful with ADA deficiency, because he or she would suffer from the same enzyme defect. However, identical twins come in handy with bone marrow transplants in leukemia; the same goes for other organ transplants. Therefore, I urge you to get yourself a twin at the earliest opportunity.

affects the 5-hydroxy group of the sugar, it is pretty obvious why this molecule is not a substrate of the kinase.

This inhibitor is effective in principle but not sufficient. There is a second enzyme, which is named *deoxycytidine kinase* but actually has a broader specificity than suggested by this name, and which also phosphorylates deoxyadenosine. In studies on cell cultures, this enzyme had to be inhibited also in order to permit lymphocytes to survive [137]. This inhibitory approach has so far only been tried in vitro; I have not yet seen any follow-up studies on its suitability in vivo.

Pentostatin is an inhibitor of adenosine deaminase. This obviously isn't useful in treating ADA deficiency, but it can be used to create experimental animal models of the condition. It is clinically used to kill lymphocytes in graft-versus-host reactions, as well as in certain forms of lymphocyte-derived malignancies.



19.3 Could 5-deoxyadenosine cause cytotoxicity by being incorporated into DNA? Why not?

19.2.3 Researching ADA enzyme therapy: first attempt

Searching PubMed for the terms in the title led me to this gem: *Adenosine Deaminase Enzyme Therapy Prevents and Reverses the Heightened Cavernal Relaxation in Priapism* [138]

Notes: Priapism is a state of sustained erection without sexual arousal and is reportedly quite painful. It seems that an increased level of extracellular adenosine, which activates adenosine receptors, can induce priapism. One possible source of extracellular adenosine is the decay of red blood cells, for example in sickle cell anemia³

According to the study cited, application of adenosine deaminase enzyme is an effective treatment for priapism. Interesting, for sure, but it has of course nothing to do with adenosine deaminase deficiency, other than that the enzyme was readily available for this therapeutic experiment because of its common use in the treatment of ADA deficiency.

19.2.4 Researching ADA enzyme therapy: second attempt

Another interesting find was this early study: *Enzyme replacement therapy for adenosine deaminase deficiency and severe combined immunodeficiency*

- strategy: application of frozen irradiated red blood cells (!)
- therapy improved immune status and helped patient survive for 17 months (while waiting for blood marrow transplant)

Notes: This study [140] was performed before the advent of recombinant methods for enzyme expression and purification. The use of red cells as carriers of the enzyme is really quite ingenious! Adenosine and deoxyadenosine can leave and

³One might expect priapism to occur in hemolytic crises in glucose-6-phosphate dehydrogenase deficiency also; anecdotal evidence seems to support this assumption [139]).

enter cells through nucleoside transporters (which have been discussed before, see slides 16.4.1 and 16.9.8), and can therefore undergo degradation inside the transfused red cells.

Notwithstanding the ingenuity of this treatment, it is bound to result in iron overload in the long term (see slide 17.5.3). A better form of treatment is to use the purified adenosine deaminase enzyme instead of blood transfusions. With modern means, the recombinantly expressed human enzyme would seem to be the obvious choice. At least in those patients that still express a nonfunctional version of the enzyme—as opposed to no enzyme at all; both variants occur—this enzyme should have the lowest likelihood of inducing inactivating antibodies. However, it seems that currently a bovine enzyme preparation is still in use [141]. Presumably, ADA deficiency patients are more tolerant toward the application of a non-self protein because of their immune defect. Furthermore, the bovine enzyme is modified with PEG, both to reduce its immunogenicity and to increase its dwell time in the system.⁴

While the inherent immunosuppression of ADA patients will facilitate the use of purified enzyme, it will also make the patients more susceptible to graft-versus-host reactions, that is, the proliferation of and immunological aggression by transferred lymphocytes. In the study cited [140], the blood cells were irradiated before transfusion, presumably in order to destroy any remaining lymphocytes and thus prevent this complication.



19.4 Why can transfusion of red blood cells be used for enzyme therapy of adenosine deaminase deficiency?

19.2.5 Gene therapy of ADA deficiency

Still at the stage of clinical studies, not mainstream. A recent study [143] was performed as follows:

- Non-myeloablative conditioning
- CD34⁺ bone marrow cells (stem cells) were isolated from the blood, transduced in vitro with a retroviral vector carrying a functional ADA gene, and reintroduced into the body
- ADA expression achieved in lymphocytes: ~5% in bone marrow, ~75% in periphery
- All patients survived at time point of compilation of study (2–8 years after treatment), but some required additional enzyme treatment

Notes: The *non-myeloablative conditioning* used in this study means that the patients' bone marrow was *not* entirely destroyed after harvesting of stem cells. Therefore, after treatment, the genetically modified cells co-existed with non-modified ones.⁵ It is noteworthy that a full 75% of T-lymphocytes in the peripheral

⁴A good review on the use of PEG to modify enzymes and other therapeutic proteins is [142].

⁵Myeloablative conditioning is the norm in allogenic bone marrow transplants, which is most commonly performed as the treatment of last resort in leukemia or lymphoma patients.

blood expressed ADA, while only 5% of the cells in the bone marrow did. This discrepancy is most likely due to the survival advantage of the ADA-expressing T-cells.

My interpretation of this cautious approach is that the investigators wanted to keep the option of an allogenic bone marrow transplant, in case the gene therapy failed. Myeloablative conditioning is very aggressive, and it can be used only once on each patient. Considering the fairly favorable outcome of this cautious initial experiment, it seems to me that a somewhat more aggressive approach, with a larger number of stem cells being transformed, and with a more intense decimation of the remaining bone marrow in the conditioning phase, is justified.



19.5 Explain the various form of therapy that can be used to treat adenosine deaminase deficiency.

19.3 Enzyme therapy of lysosomal enzyme defects

Adenosine deaminase is active in the cytoplasm, and since the substrates can enter and leave the cells by facilitated diffusion, there is no major problem with arranging for the enzyme to meet its substrate. However, this is different in lysosomal enzyme defects.

Lysosomes contain a diverse range of hydrolytic enzymes (hydrolases), which are important in the breakdown of both extracellular and intracellular molecules. These enzymes have an acidic pH optimum, which matches the acidic environment inside phagolysosomes, that is, the vesicles that form by fusion of substrate-containing vesicles with lysosomes.

There are quite a few hereditary enzyme defects that concern one or the other lysosomal hydrolase, and depending on the type of compound that now can no longer be degraded and therefore accumulates, these diseases are referred to as lipidoses, mucopolysaccharidoses, or glycogenoses.

When a lysosomal enzyme is deficient, the substrate nevertheless continues to be targeted to phagolysosomes. Therefore, in order to treat this condition with enzyme therapy, we need to get the enzyme into the lysosomes as well. We will look at some examples to understand how this can be achieved.

19.3.1 Pompe disease

- defect of acid maltase, a lysosomal enzyme
- glycogen accumulates
- various forms: complete absence of enzyme (manifestation in infants) vs. residual activity (manifestation in older children or adolescents)
- affects mainly the skeletal muscle; glycogen accumulation leads to muscle tissue degeneration
- muscle strength progressively degrades, to the point that patients are no longer able to breathe

Notes: In Pompe disease, the deficient enzyme is acid maltase (see slide 8.6.2). Without this enzyme, lysosomal glycogen degradation stalls (see slide 8.3.7), and undegraded glycogen particles slowly accumulate. The accumulation of glycogen concerns mostly skeletal and heart muscle and leads to the degeneration of these tissues.

19.3.2 Enzyme therapy of Pompe disease

- recombinant enzyme expressed in rabbit mammary glands, isolated from rabbit milk
- target group: juvenile patients (not infants)
- dosage: 20 mg/kg every two weeks
- clinical outcome: improvement of muscle strength, but not to normal level
- no severe immune reactions

Notes: The dosage of enzyme applied in this clinical study [144] is quite large; it is remarkable that enough of it can be obtained from rabbits. Even with this large amount of enzyme, the success of the treatment is only partial; this is most likely related to the limited efficiency of targeting the enzyme to the lysosomes.

19.3.3 Clinical outcome of enzyme therapy: Muscle strength

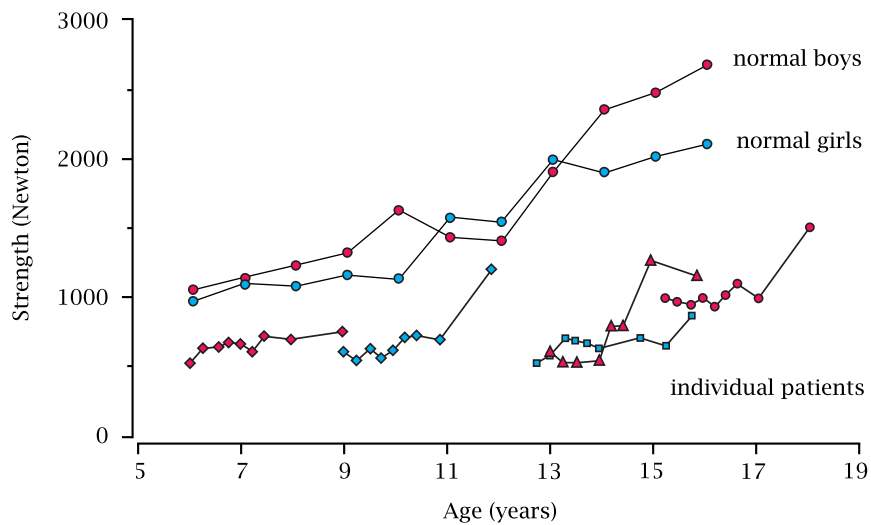

Notes: The two continuous curves at the top are the references for boys and girls. The shorter graphs at the bottom show the data from individual patients over the time course of the study. It is evident that muscle strength improves but remains below normal.

Figure adapted from [144]. Also note the very clever color coding used in the figure.

19.3.4 The mannose-6-phosphate receptor targets proteins to the lysosome

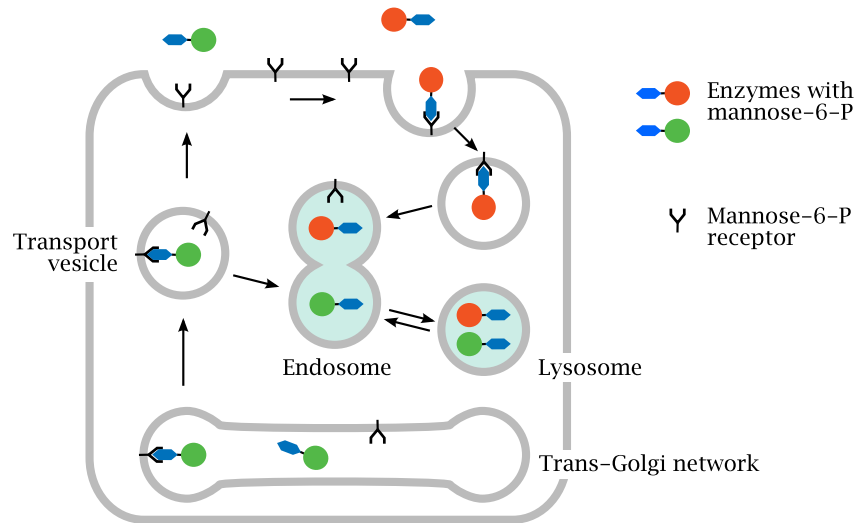

Notes: This cartoon—loosely based on one from [145]—illustrates the role of the mannose-6-phosphate receptor in targeting proteins to the lysosomes and endosomes. Proteins that contain the sugar mannose-6-phosphate in their glycosyl moieties can bind to the mannose-6-phosphate receptor, a membrane protein that occurs in several types of intracellular vesicles and compartments. The receptor picks up lysosomal enzymes within the trans-Golgi network and ensures that they indeed make their way to the lysosomes. Acid maltase is one of the proteins that are transported to the lysosomes by this mechanism.

Some mannose-6-phosphate receptor molecules also make their way to the cell surface. These receptor molecules can bind to acid maltase that was applied therapeutically and is present in the extracellular space. The receptor-enzyme complexes will undergo endocytosis and find themselves in endosomes that reversibly fuse with lysosomes. Hitching a ride inside a vagrant lysosome, an enzyme molecule may eventually alight upon the undegraded substrate within another endosome. Considering how roundabout and haphazard this transport process is, it is perhaps not surprising that the targeting of therapeutically applied lysosomal enzymes is not very efficient.

19.3.5 Optimization of acid maltase glycosylation

Notes: Protein glycosylation occurs within the Golgi apparatus and the trans-Golgi network. It is a stepwise process, in which several different glycosyltransferases attach sugar moieties to the ends of growing oligosaccharide chains. The composition of the oligosaccharide moieties attached to a given protein can vary with the host cell that expresses it. In the case of lysosomal enzymes, such differences may affect the rate of uptake into cells.

The experimental study summarized in this slide illustrates the importance of the carbohydrate moiety for cellular uptake. Acid maltase was expressed in

control CHO cells (blue lines) and in a derived cell line engineered for increased incorporation of mannose-6-phosphate into the oligosaccharides (green lines, CHO M6P[↑]). The enzyme expressed in these cells contains greater amounts of mannose-6-phosphate than a control sample obtained from CHO cells (left), and it is indeed taken up more efficiently into cells lacking the enzyme (right). Figure prepared from original data in [146].

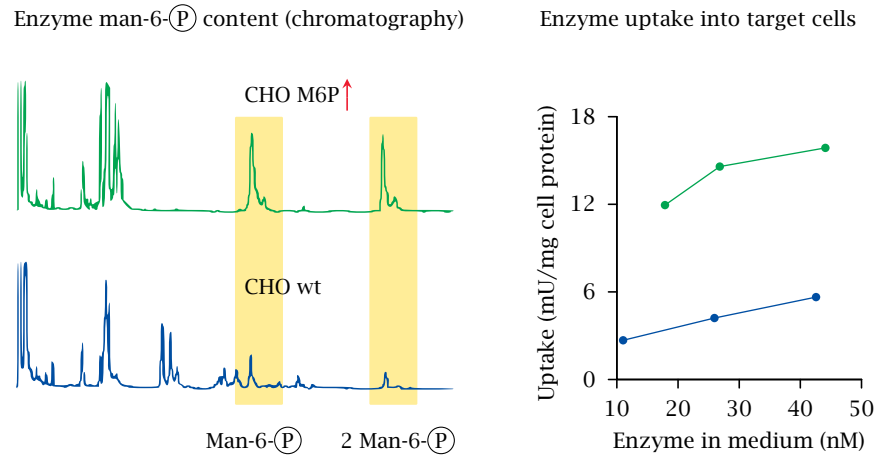

In the following slides, we will, as a final example, take a look at Gaucher disease. This is another lysosomal enzyme defect that displays some interesting and instructive differences to Pompe disease.

19.3.6 The biochemical defect in Gaucher disease

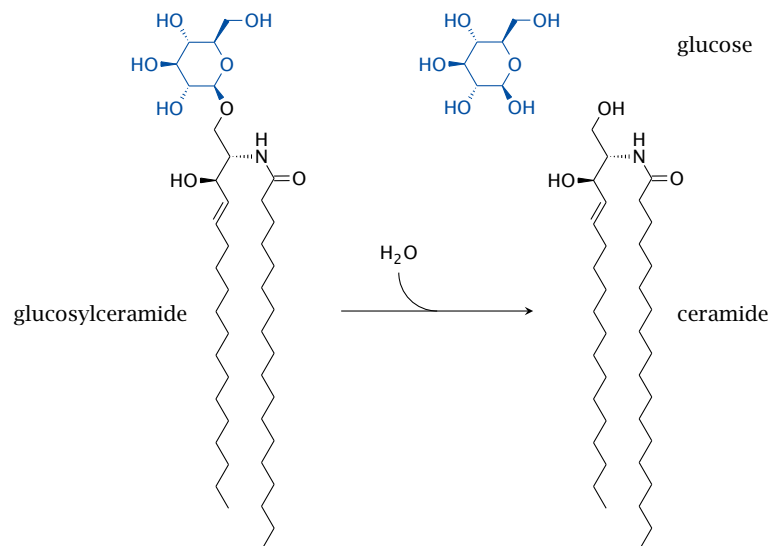

Notes: Glucocerebrosidase hydrolyzes glucosylceramide, a glycosphingolipid that occurs in cell membranes. The enzyme defect affects mostly macrophages, since these cells take up expired cells and degrade their constituents. Via an unknown mechanism, the accumulation of glucosylceramide inside the macrophages

causes inflammatory, proliferative and degenerative changes in those organs that host a lot of macrophages, that is, liver, spleen, and bone marrow.

Enzyme therapy again requires the uptake of the enzyme molecules into the cells and the lysosomes. However, this is easier to achieve with macrophages than with most other cell types. Macrophages have multiple cell surface receptors that promote uptake, such as for example immunoglobulin receptors.⁶ Another receptor class are *lectins*, that is, sugar-binding proteins. Their normal function is to bind to the cell surface oligosaccharides of microbes and mediate their phagocytosis. One of these lectins, the mannose receptor, can be targeted to facilitate the uptake of therapeutically applied glucocerebrosidase.

19.3.7 Partial deglycosylation of glucocerebrosidase accelerates uptake into macrophages

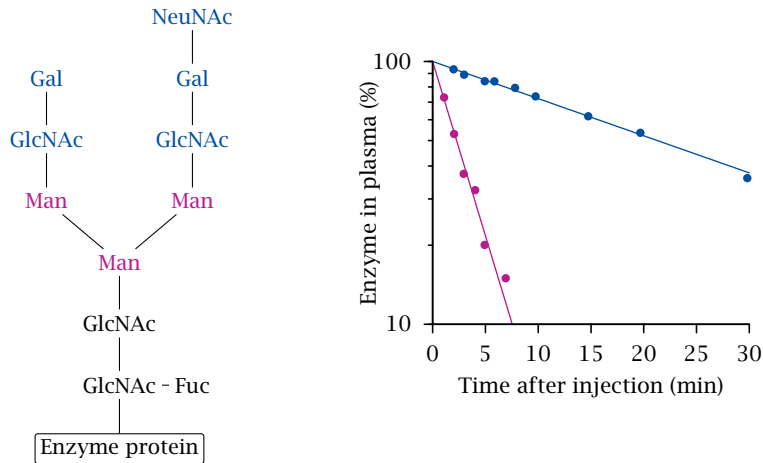

Notes: Glucocerebrosidase contains a posttranslationally attached oligosaccharide moiety that has a characteristic sequence of specific sugars. The terminal sugars—N-acetylneuraminic acid, galactose, and N-acetylglucosamine—can be removed using specific glycosidases; this will expose the mannose residues contained within and thus enable the binding of the enzyme to mannose receptors. The experiment depicted here shows that this partial deglycosylation greatly accelerates the clearance of the enzyme from plasma, such that the plasma half-life drops from 21 minutes to 2.3 minutes. Much of the rapidly cleared enzyme winds up inside the macrophages, where it can digest accumulated glucocerebroside. Figure prepared from original data in [147].

Enzyme therapy of Gaucher disease is remarkably effective and is the current standard of treatment.

⁶Another aspect that likely facilitates the uptake of enzyme by macrophages is the absence of an endothelial barrier. While muscle cells are separated from the blood flow by a continuous endothelium, the macrophages in the spleen and liver reside directly within the blood-percolated sinusoids.

19.3.8 Drug treatment of Gaucher disease

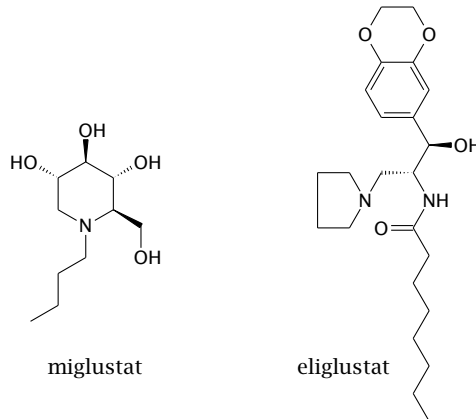

Notes: These two drugs are inhibitors of glucocerebroside synthesis. Total inhibition of glucocerebroside synthesis is not compatible with life, so this strategy does not obviate the need for enzyme therapy and is not free of side effects.

Serendipitously, miglustat was also found to inhibit spermatogenesis in mice, suggesting a new approach for male contraception. This effect, however, could not be substantiated in men [148].



19.6 Explain the fundamental problem with enzyme therapy of lysosomal enzyme defects, and how it can be overcome. Explain how enzyme therapy works in Pompe disease and in Gaucher disease.

19.4 Answers to practice questions

19.1: Cells in transplanted organs retain the intact genes of the organ donor, and therefore will express an intact version of the enzyme that is deficient in the recipient's body. Transplantation can be used in those enzyme defects that affect mostly one organ, such as the liver or the bone marrow.

19.2: Advantage: Integration of vector into host cell DNA enables permanent, stable expression of transferred gene. Disadvantage: The virus inserts into the DNA at randomly chosen locations. This can occasionally lead to the activation of dormant tumor-promoting genes and thereby to cancer or leukemia.

19.3: Consider the reactions that precede the incorporation of a nucleotide into DNA. (No, this is not a sufficient answer, but rather a hint at how to arrive at one.)

19.4: Red blood cells, as well as other cells, contain nucleoside transporters that allow deoxyadenosine and other nucleosides to freely pass into and out the cells. Therefore, dA can enter the transfused red cells and be converted to deoxyinosine, which can then leave the cells and be completely degraded elsewhere.

19.5:

1. Enzyme therapy: Parenteral substitution of the enzyme. This needs to be repeated indefinitely.

2. Allogenic bone marrow transplant: The patient's bone marrow is replaced using bone marrow stem cells from a healthy relative. Curative but potentially severe side effects and complications due to immunological incompatibility.

3. Gene therapy: Intact copies of the adenosine deaminase gene are transferred into the patient's own bone marrow stem cells. Potentially curative if genes are stably expressed. Avoids immunological complications of bone marrow transplant but, at least with retroviral vectors, has risks such as leukemia.

4. Drug therapy: Inhibition of salvage pathway kinases that convert deoxyadenosine to dATP. Experimental and unproven.

19.6: The fundamental problem is that lysosomal enzymes are active only inside lysosomes, but intravenously applied enzymes are not usually transported into lysosomes. The problem can be overcome by endowing the enzymes with oligosaccharide moieties which are recognized by cellular receptors that trigger endocytosis.

On nucleated cells in general, endocytosis and transport to the lysosomes is facilitated by the mannose-6-phosphate receptor. This is exploited in Pompe disease, which is caused by a lack of the lysosomal enzyme acid maltase. Recombinantly expressed acid maltase carrying mannose-6-phosphate is taken up by muscle cells via the mannose-6-phosphate receptor.

Gaucher disease affects macrophages; the missing enzyme is glucocerebrosidase. These cells have a mannose receptor, which normally serves to mediate phagocytosis of microbes. Glucocerebrosidase is purified and partially deglycosylated in order to expose mannose residues contained within its natural oligosaccharide moiety. This modified enzyme is rapidly and efficiently taken up by macrophages.

Chapter 20

Credits and copyright

20.1 Preliminary note

Most of the illustrations in these notes were created by me; this is the case for all plots, reaction schemes, molecular structures, and cartoons, except where stated otherwise. These images—like the text, which was entirely written by me—are subject to the terms of the copyright notice below.

Photographs were obtained from various sources. Most of the histological images were obtained from pathorama.ch and are reproduced here with the kind permission of that website's owner, Katharina Glatz. All micrographs for which another source is *not* specified below were obtained from this source.

For all other photographs, the sources are listed below, as far as I have been able to ascertain them. These images have been used either with explicit permission of the originating websites' owners, or under the following rationales:

- Images from wikipedia: These are usually released under the [Creative Commons 3.0](https://creativecommons.org/licenses/by/3.0/) license, which permits their incorporation, in unchanged form, into a collection, without affecting the copyright of the resulting collection as a whole. I believe that these lecture notes and slides constitute a collection conforming to this clause.
- Images from individual sources, for which no copyright holder could be identified, or for which requests for permission to reuse went unanswered: the use of these images is deemed appropriate (1) because of general [fair use](https://creativecommons.org/licenses/by/3.0/) considerations, and/or (2) because the images in question constitute faithful reproductions of physical phenomena, without artistic originality, and therefore, according to a [decision](https://www.courts.gov/courts_of_appeals/) by the US Court of Appeals, are not subject to copyright protection.

If you have the rights to an image used without explicit permission and credit, and you do not agree with its use in these notes, please let me know, and I will

remove that image. If you have the rights and you *do* agree with its use, I would appreciate a brief note to this effect, so that I can give you the proper credit.

20.2 Individual image credits

All images not listed here are my own work.

Slide	Source
1.6.10	Right: with kind permission by Roger Wagner, University of Delaware. Left: From pathorama.ch .
2.3.1	Left: from bayregio.de ; right: author's own work.
8.6.2	Panel 1: from pathorama.ch , panel 2: from wikipedia , panels 3 and 4: Origin and copyright ownership unknown.
9.3.7	Photograph by Tommaso Leonardi, via wikipedia .
9.4.1	Photograph downloaded from morguefile.com . Image was stated to be available without attribution; it seems to have been removed since from the website.
9.4.3	Photograph by Ernst Hempelmann, via wikipedia . β -Hematin structure rendered from coordinates kindly provided by Katherine de Villiers.
10.3.8	From reference [149].
11.2.8	From Histology@Yale with kind permission by Peter Takizawa.
13.2.3	Photograph from the University of Toronto Image Bank . Image is in the public domain.
13.2.4	Left: poster by Song Ren. Image obtained via the International Institute of Social History . Right: photograph by Claudette Bue, via wikipedia .
13.2.5	Portrait from Michigan State University . On the website, Dr. Sanger himself is listed as the source of the photograph.
13.2.7	Cartoons downloaded from childcoloringpages.net and pagestocolor.net . Subsequently converted to vector graphics format. Both websites stated the images to be free and did not identify the creators.
13.3.8	This image is found in multiple locations on the web. According to this reference , the image originated with Jackson Laboratories.
14.4	EM image from the Public Health Image Library of the CDC (id 5630). Image is in the public domain.
15.4.7	From Histology@Yale with permission by Peter Takizawa.
15.5.3	Origin and copyright ownership unknown
17.3.1	Origin and copyright ownership unknown
17.3.3	From the Cleveland Clinic Center for Continuing Education with permission

20.3 Copyright notice

No part of this document may be reproduced without written consent from the author, except as follows:

- You may download an electronic copy for your personal use.
- You may print a copy for your personal use.
- If you are an instructor and use these notes in teaching your class, you may distribute electronic copies free of charge to your students. You may also distribute printed copies to them for free; or you may charge a fee, but only to cover the costs of printing, without any surcharge.
- You may adapt the accompanying set of PowerPoint presentations by rearranging, adding, deleting, or modifying individual slides. The modified presentations may be shared with your class or with other instructors, but you may not charge a fee for such modified files.
- You may use individual images or short excerpts in keeping with general fair use considerations. In any such use, proper attribution must be made.

It is not permissible to post any of these files on a publicly accessible web server. Exempt from this restriction are websites access to which is restricted to the students of a class that uses these notes and slides as teaching materials.

All the above clauses apply to all file formats of this document—currently HTML, ePub and PDF—as well as to the accompanying sets of PDF and PowerPoint slides.

Exempt from all above restrictions are several images that have been obtained from third parties, and which are identified in section 20.2 above. Refer to the originators of those works for copyright restrictions that may apply to your intended reuse.

Bibliography

- [1] X. Wu and G. Brewer. "The regulation of mRNA stability in mammalian cells: 2.0". *Gene* 500 (2012), 10-21. PMID: [22452843](#) (cited on p. 28).
- [2] J. H. Lee *et al.* "Crystal structure of rabbit phosphoglucose isomerase complexed with its substrate D-fructose 6-phosphate". *Biochemistry* 40 (2001), 7799-7805. PMID: [11425306](#) (cited on p. 37).
- [3] M. Larion and B. G. Miller. "Homotropic allosteric regulation in monomeric mammalian glucokinase". *Arch Biochem Biophys* 519 (2012), 103-111. PMID: [22107947](#) (cited on p. 44).
- [4] M. D. Meglasson and F. M. Matschinsky. "Discrimination of glucose anomers by glucokinase from liver and transplantable insulinoma". *J Biol Chem* 258 (1983), 6705-6708. PMID: [6304052](#) (cited on p. 44).
- [5] F. Raggi and D. S. Kronfeld. "Higher glucose affinity of hexokinase in sheep brain than in rat brain" (1966) (cited on p. 44).
- [6] F.-Q. Zhao and A. F. Keating. "Functional properties and genomics of glucose transporters". *Curr Genomics* 8 (2007), 113-128. PMID: [18660845](#) (cited on p. 44).
- [7] J. C. Bode *et al.* "Depletion of liver adenosine phosphates and metabolic effects of intravenous infusion of fructose or sorbitol in man and in the rat". *Eur J Clin Invest* 3 (1973), 436-441. PMID: [4772339](#) (cited on p. 49).
- [8] C. Ning *et al.* "Galactose metabolism by the mouse with galactose-1-phosphate uridylyltransferase deficiency". *Pediatr Res* 48 (2000), 211-217. PMID: [10926297](#) (cited on p. 53).
- [9] B. Panis *et al.* "Untreated classical galactosemia patient with mild phenotype". *Mol Genet Metab* 89 (2006), 277-279. PMID: [16621642](#) (cited on p. 53).
- [10] N. D. Leslie. "Insights into the pathogenesis of galactosemia". *Annu Rev Nutr* 23 (2003), 59-80. PMID: [12704219](#) (cited on p. 53).
- [11] G. T. Berry. "Is prenatal myo-inositol deficiency a mechanism of CNS injury in galactosemia?" *J Inherit Metab Dis* 34 (2011), 345-355. PMID: [21246399](#) (cited on p. 53).
- [12] J. B. Holton *et al.* "Galactosaemia: a new severe variant due to uridine diphosphate galactose-4-epimerase deficiency". *Arch Dis Child* 56 (1981), 885-887. PMID: [7305435](#) (cited on p. 53).
- [13] I. Morgunov and P. A. Srere. "Interaction between citrate synthase and malate dehydrogenase. Substrate channeling of oxaloacetate". *J Biol Chem* 273 (1998), 29540-29544. PMID: [9792662](#) (cited on p. 59).

Bibliography

- [14] J. W. A. Graham *et al.* "Glycolytic enzymes associate dynamically with mitochondria in response to respiratory demand and support substrate channeling". *Plant Cell* 19 (2007), 3723–3738. PMID: [17981998](#) (cited on p. 59).
- [15] M. Karpusas, B. Branchaud, and S. J. Remington. "Proposed mechanism for the condensation reaction of citrate synthase: 1.9-A structure of the ternary complex with oxaloacetate and carboxymethyl coenzyme A". *Biochemistry* 29 (1990), 2213–2219. PMID: [2337600](#) (cited on p. 64).
- [16] T. Yagi and A. Matsuno-Yagi. "The proton-translocating NADH-quinone oxidoreductase in the respiratory chain: the secret unlocked". *Biochemistry* 42 (2003), 2266–2274. PMID: [12600193](#) (cited on p. 75).
- [17] X. Liu *et al.* "Induction of apoptotic program in cell-free extracts: requirement for dATP and cytochrome c". *Cell* 86 (1996), 147–157. PMID: [8689682](#) (cited on p. 78).
- [18] A. Colell, D. R. Green, and J. . E. Ricci. "Novel roles for GAPDH in cell death and carcinogenesis". *Cell Death Differ* 16 (2009), 1573–1581. PMID: [19779498](#) (cited on p. 78).
- [19] V. K. Rastogi and M. E. Girvin. "Structural changes linked to proton translocation by subunit c of the ATP synthase". *Nature* 402 (1999), 263–268. PMID: [10580496](#) (cited on p. 91).
- [20] S. Passarella *et al.* "Oxaloacetate uptake into rat brain mitochondria and reconstruction of the malate/oxaloacetate shuttle". *Biochem Biophys Res Commun* 119 (1984), 1039–1046. PMID: [6712663](#) (cited on p. 92).
- [21] A. Atlante *et al.* "Mitochondria from the left heart ventricles of both normotensive and spontaneously hypertensive rats oxidize externally added NADH mostly via a novel malate/oxaloacetate shuttle as reconstructed in vitro". *Int J Mol Med* 18 (2006), 177–186. PMID: [16786170](#) (cited on p. 92).
- [22] B. Safer. "The Metabolic Significance of the Malate-Aspartate Cycle in Heart". *Circ Res* 37 (1975), 527–533. PMID: [172258](#) (cited on p. 93).
- [23] J. T. Barron, L. Gu, and J. E. Parrillo. "Malate-aspartate shuttle, cytoplasmic NADH redox potential, and energetics in vascular smooth muscle". *J Mol Cell Cardiol* 30 (1998), 1571–1579. PMID: [9737943](#) (cited on p. 93).
- [24] A. S. Divakaruni and M. D. Brand. "The regulation and physiology of mitochondrial proton leak". *Physiology (Bethesda)* 26 (2011), 192–205. PMID: [21670165](#) (cited on p. 95).
- [25] L. A. Sazanov and J. B. Jackson. "Proton-translocating transhydrogenase and NAD- and NADP-linked isocitrate dehydrogenases operate in a substrate cycle which contributes to fine regulation of the tricarboxylic acid cycle activity in mitochondria". *FEBS Lett* 344 (1994), 109–116. PMID: [8187868](#) (cited on p. 96).
- [26] C.-Y. Chou, L. P. C. Yu, and L. Tong. "Crystal structure of biotin carboxylase in complex with substrates and implications for its catalytic mechanism". *J Biol Chem* 284 (2009), 11690–11697. PMID: [19213731](#) (cited on p. 104).
- [27] M. L. Halperin, C. M. Schiller, and I. B. Fritz. "The inhibition by methylmalonic acid of malate transport by the dicarboxylate carrier in rat liver mitochondria. A possible explanation for hypoglycemia in methylmalonic aciduria". *J Clin Invest* 50 (1971), 2276–2282. PMID: [4398537](#) (cited on p. 107).
- [28] A. Burchell. "Endoplasmic reticulum phosphate transport". *Kidney Int* 49 (1996), 953–958. PMID: [8691743](#) (cited on p. 109).

- [29] E. Goldsmith, S. Sprang, and R. Fletterick. "Structure of maltoheptaose by difference Fourier methods and a model for glycogen". *J Mol Biol* 156 (1982), 411–427. PMID: [7086906](#) (cited on p. 115).
- [30] P. J. Roach *et al.* "Glycogen and its metabolism: some new developments and old themes". *Biochem J* 441 (2012), 763–787. PMID: [22248338](#) (cited on pp. 115, 121).
- [31] F. Sheng *et al.* "The crystal structures of the open and catalytically competent closed conformation of *Escherichia coli* glycogen synthase". *J Biol Chem* 284 (2009), 17796–17807. PMID: [19244233](#) (cited on p. 119).
- [32] J.-J. Shieh *et al.* "A glucose-6-phosphate hydrolase, widely expressed outside the liver, can explain age-dependent resolution of hypoglycemia in glycogen storage disease type Ia". *J Biol Chem* 278 (2003), 47098–47103. PMID: [13129915](#) (cited on p. 125).
- [33] L. A. Nolte, E. A. Gulve, and J. O. Holloszy. "Epinephrine-induced in vivo muscle glycogen depletion enhances insulin sensitivity of glucose transport". *J Appl Physiol* (1985) 76 (1994), 2054–2058. PMID: [7914887](#) (cited on p. 125).
- [34] C. F. Cori and G. T. Cori. "Glycogen formation in the liver from D- and L-lactic acid". *J Biol Chem* 81 (1929), 389–403 (cited on p. 125).
- [35] H. L. Greene *et al.* "ATP depletion, a possible role in the pathogenesis of hyperuricemia in glycogen storage disease type I". *J Clin Invest* 62 (1978), 321–328. PMID: [276529](#) (cited on p. 127).
- [36] B. Burwinkel *et al.* "Autosomal glycogenosis of liver and muscle due to phosphorylase kinase deficiency is caused by mutations in the phosphorylase kinase subunit (PHKB)". *Hum Mol Genet* 6 (1997), 1109–1115. PMID: [9215682](#) (cited on p. 128).
- [37] C. A. Worby, M. S. Gentry, and J. E. Dixon. "Laforin, a dual specificity phosphatase that dephosphorylates complex carbohydrates". *J Biol Chem* 281 (2006), 30412–30418. PMID: [16901901](#) (cited on p. 128).
- [38] E. Racker and E. Schroeder. "Formation and utilization of octulose-8-phosphate by transaldolase and transketolase". *Arch Biochem Biophys* 66 (1957), 241–243. PMID: [13395544](#) (cited on p. 134).
- [39] R. L. Veech, L. V. Eggleston, and H. A. Krebs. "The redox state of free nicotinamide-adenine dinucleotide phosphate in the cytoplasm of rat liver". *Biochem J* 115 (1969), 609–619. PMID: [4391039](#) (cited on p. 137).
- [40] J. K. Suagee *et al.* "De novo fatty acid synthesis and NADPH generation in equine adipose and liver tissue". *Comp Biochem Physiol B Biochem Mol Biol* 155 (2010), 322–326. PMID: [19962447](#) (cited on p. 139).
- [41] M. F. Lyon. "Gene action in the X-chromosome of the mouse (*Mus musculus* L.)". *Nature* 190 (1961), 372–373. PMID: [13764598](#) (cited on p. 142).
- [42] E. Beutler, M. Yeh, and V. F. Fairbanks. "The normal human female as a mosaic of X-chromosome activity: studies using the gene for G-6-PD-deficiency as a marker". *Proc Natl Acad Sci U S A* 48 (1962), 9–16. PMID: [13868717](#) (cited on p. 142).
- [43] F. Carriere *et al.* "Secretion and contribution to lipolysis of gastric and pancreatic lipases during a test meal in humans". *Gastroenterology* 105 (1993), 876–888. PMID: [8359655](#) (cited on p. 150).
- [44] Y. Gargouri, H. Moreau, and R. Verger. "Gastric lipases: biochemical and physiological studies". *Biochim Biophys Acta* 1006 (1989), 255–271. PMID: [2688745](#) (cited on p. 150).

Bibliography

- [45] M. Roulet *et al.* "Gastric emptying and lingual lipase activity in cystic fibrosis". *Pediatr Res* 14 (1980), 1360-1362. PMID: [7208153](#) (cited on p. 160).
- [46] G. J. van Stekelenburg and G. Koorevaar. "Evidence for the existence of mammalian acetoacetate decarboxylase: with special reference to human blood serum". *Clin Chim Acta* 39 (1972), 191-199. PMID: [4624981](#) (cited on p. 161).
- [47] G. Koorevaar and G. J. van Stekelenburg. "Mammalian acetoacetate decarboxylase activity. Its distribution in subfractions of human albumin and occurrence in various tissues of the rat". *Clin Chim Acta* 71 (1976), 173-183. PMID: [963888](#) (cited on p. 162).
- [48] J. P. Casazza, M. E. Felver, and R. L. Veech. "The metabolism of acetone in rat". *J Biol Chem* 259 (1984), 231-236. PMID: [6706932](#) (cited on pp. 162, 163).
- [49] G. A. J. Reichard *et al.* "Plasma acetone metabolism in the fasting human". *J Clin Invest* 63 (1979), 619-626. PMID: [438326](#) (cited on p. 162).
- [50] M. J. Sulway and J. M. Malins. "Acetone in diabetic ketoacidosis". *Lancet* 2 (1970), 736-740. PMID: [4195976](#) (cited on pp. 163, 255).
- [51] E. P. G. Vining. "The ketogenic diet". *Adv Exp Med Biol* 497 (2002), 225-231. PMID: [11993735](#) (cited on p. 163).
- [52] M. Gasior *et al.* "The anticonvulsant activity of acetone, the major ketone body in the ketogenic diet, is not dependent on its metabolites acetol, 1,2-propanediol, methylglyoxal, or pyruvic acid". *Epilepsia* 48 (2007), 793-800. PMID: [17386058](#) (cited on p. 163).
- [53] M. Palmer. "Combination treatment of epilepsy with ketogenic diet and concurrent pharmacological inhibition of cytochrome P450 2E1". *Med Hypotheses* 80 (2013), 481-485. PMID: [23363738](#) (cited on p. 163).
- [54] J. R. Stern. "A role of acetoacetyl-CoA synthetase in acetoacetate utilization by rat liver cell fractions". *Biochem Biophys Res Commun* 44 (1971), 1001-1007. PMID: [5125223](#) (cited on p. 168).
- [55] G. Endemann *et al.* "Lipogenesis from ketone bodies in the isolated perfused rat liver. Evidence for the cytosolic activation of acetoacetate". *J Biol Chem* 257 (1982), 3434-3440. PMID: [7061490](#) (cited on p. 168).
- [56] B. M. Buckley and D. H. Williamson. "Acetoacetyl-CoA synthetase; a lipogenic enzyme in rat tissues". *FEBS Lett* 60 (1975), 7-10. PMID: [1227960](#) (cited on p. 168).
- [57] T. Puig *et al.* "Novel Inhibitors of Fatty Acid Synthase with Anticancer Activity". *Clin Cancer Res* 15 (2009), 7608-7615. PMID: [20008854](#) (cited on p. 170).
- [58] Y. Sakakura *et al.* "Sterol regulatory element-binding proteins induce an entire pathway of cholesterol synthesis". *Biochem Biophys Res Commun* 286 (2001), 176-183. PMID: [11485325](#) (cited on p. 181).
- [59] J. L. Goldstein, R. A. DeBose-Boyd, and M. S. Brown. "Protein sensors for membrane sterols". *Cell* 124 (2006), 35-46. PMID: [16413480](#) (cited on p. 182).
- [60] D. Steinberg. "Atherogenesis in perspective: hypercholesterolemia and inflammation as partners in crime". *Nat Med* 8 (2002), 1211-1217. PMID: [12411947](#) (cited on p. 191).
- [61] K. Rajamäki *et al.* "Cholesterol crystals activate the NLRP3 inflammasome in human macrophages: a novel link between cholesterol metabolism and inflammation". *PLoS One* 5 (2010), e11765. PMID: [20668705](#) (cited on pp. 193, 302).

- [62] F. Martinon *et al.* "Gout-associated uric acid crystals activate the NALP3 inflammasome". *Nature* 440 (2006), 237–241. PMID: [16407889](#) (cited on pp. 193, 302).
- [63] Z. Wang *et al.* "Protein carbamylation links inflammation, smoking, uremia and atherogenesis". *Nat Med* 13 (2007), 1176–1184. PMID: [17828273](#) (cited on p. 195).
- [64] S. Bhakdi *et al.* "Beyond cholesterol: the enigma of atherosclerosis revisited". *Thromb Haemost* 91 (2004), 639–645. PMID: [15045123](#) (cited on p. 195).
- [65] D. Adams. *The Hitchhiker's Guide to the Galaxy*. Pan Macmillan, 2005. ISBN: 9780330438957. URL: <http://books.google.ca/books?id=jo8wHAAACAAJ> (cited on p. 198).
- [66] V. V. Bamm *et al.* "Haptoglobin phenotypes differ in their ability to inhibit heme transfer from hemoglobin to LDL". *Biochemistry* 43 (2004), 3899–3906. PMID: [15049697](#) (cited on p. 198).
- [67] J. Delanghe *et al.* "Haptoglobin polymorphism and peripheral arterial occlusive disease". *Atherosclerosis* 145 (1999), 287–292. PMID: [10488955](#) (cited on p. 198).
- [68] A. S. Goldberg and R. A. Hegele. "Cholesteryl ester transfer protein inhibitors for dyslipidemia: focus on dalcetrapib". *Drug Des Devel Ther* 6 (2012), 251–259. PMID: [23055695](#) (cited on p. 200).
- [69] D. Lütjohann *et al.* "Long-term efficacy and safety of ezetimibe 10 mg in patients with homozygous sitosterolemia: a 2-year, open-label extension study". *Int J Clin Pract* 62 (2008), 1499–1510. PMID: [18822021](#) (cited on p. 204).
- [70] K. Tsubakio-Yamamoto *et al.* "Current therapy for patients with sitosterolemia—effect of ezetimibe on plant sterol metabolism". *J Atheroscler Thromb* 17 (2010), 891–900. PMID: [20543520](#) (cited on p. 204).
- [71] J. T. Brosnan. "Glutamate, at the interface between amino acid and carbohydrate metabolism". *J Nutr* 130 (2000), 988S–990S. PMID: [10736367](#) (cited on p. 209).
- [72] T. Yamada *et al.* "Crystal structure of serine dehydratase from rat liver". *Biochemistry* 42 (2003), 12854–12865. PMID: [14596599](#) (cited on p. 221).
- [73] Y. H. Loo. "Serotonin deficiency in experimental hyperphenylalaninemia". *J Neurochem* 23 (1974), 139–147. PMID: [4546911](#) (cited on p. 224).
- [74] L. I. Wolf. "The heterozygote advantage in phenylketonuria". *Am J Hum Genet* 38 (1986), 773–775. PMID: [3717163](#) (cited on pp. 225, 226).
- [75] F. Sanger. "Sequences, sequences, and sequences". *Annu Rev Biochem* 57 (1988), 1–28. PMID: [2460023](#) (cited on p. 233).
- [76] J. Wahren, A. Kallas, and A. A. F. Sima. "The clinical potential of C-peptide replacement in type 1 diabetes". *Diabetes* 61 (2012), 761–772. PMID: [22442295](#) (cited on pp. 233, 263).
- [77] B. M. Vayssière *et al.* "Synthetic glucocorticoids that dissociate transactivation and AP-1 transrepression exhibit antiinflammatory activity in vivo". *Mol Endocrinol* 11 (1997), 1245–1255. PMID: [9259316](#) (cited on p. 245).
- [78] E. M. King *et al.* "Glucocorticoid repression of inflammatory gene expression shows differential responsiveness by transactivation- and transrepression-dependent mechanisms". *PLoS One* 8 (2013), e53936. PMID: [23349769](#) (cited on p. 245).
- [79] S. T. Russell *et al.* "Mechanism of induction of muscle protein loss by hyperglycaemia". *Exp Cell Res* 315 (2009), 16–25. PMID: [18973755](#) (cited on p. 253).

Bibliography

- [80] K. Nylen, S. Likhodii, and W. M. Burnham. "The ketogenic diet: proposed mechanisms of action". *Neurotherapeutics* 6 (2009), 402–405. PMID: [19332336](#) (cited on p. 255).
- [81] V. Postolache *et al.* "[Effect of acetone upon barbiturate anesthesia]". *Arch Toxicol* 25 (1969), 333–337. PMID: [5384572](#) (cited on p. 255).
- [82] K. S. MacDonald *et al.* "Influence of HLA supertypes on susceptibility and resistance to human immunodeficiency virus type 1 infection". *J Infect Dis* 181 (2000), 1581–1589. PMID: [10823757](#) (cited on p. 258).
- [83] K. E. Schemmel, R. S. Padiyara, and J. J. D'Souza. "Aldose reductase inhibitors in the treatment of diabetic peripheral neuropathy: a review". *J Diabetes Complications* 24 (2010), 354–360. PMID: [19748287](#) (cited on p. 263).
- [84] R. A. Miller *et al.* "Biguanides suppress hepatic glucagon signalling by decreasing production of cyclic AMP". *Nature* 494 (2013), 256–260. PMID: [23292513](#) (cited on p. 267).
- [85] M. R. Owen, E. Doran, and A. P. Halestrap. "Evidence that metformin exerts its anti-diabetic effects through inhibition of complex 1 of the mitochondrial respiratory chain". *Biochem J* 348 Pt 3 (2000), 607–614. PMID: [10839993](#) (cited on p. 267).
- [86] S. A. Hawley *et al.* "The antidiabetic drug metformin activates the AMP-activated protein kinase cascade via an adenine nucleotide-independent mechanism". *Diabetes* 51 (2002), 2420–2425. PMID: [12145153](#) (cited on p. 267).
- [87] M. Foretz *et al.* "Metformin inhibits hepatic gluconeogenesis in mice independently of the LKB1/AMPK pathway via a decrease in hepatic energy state". *J Clin Invest* 120 (2010), 2355–2369. PMID: [20577053](#) (cited on p. 267).
- [88] V. Schirch and D. M. Szebenyi. "Serine hydroxymethyltransferase revisited". *Curr Opin Chem Biol* 9 (2005), 482–487. PMID: [16125438](#) (cited on p. 271).
- [89] D. G. Weir and J. M. Scott. "The biochemical basis of the neuropathy in cobalamin deficiency". *Baillieres Clin Haematol* 8 (1995), 479–497. PMID: [8534958](#) (cited on pp. 277, 279).
- [90] J. van der Westhuyzen *et al.* "Effect of a vitamin B-12-deficient diet on lipid and fatty acid composition of spinal cord myelin in the fruit bat". *J Nutr* 113 (1983), 531–537. PMID: [6131113](#) (cited on p. 277).
- [91] S. Aufreiter *et al.* "Folate is absorbed across the colon of adults: evidence from cecal infusion of (13)C-labeled [6S]-5-formyltetrahydrofolic acid". *Am J Clin Nutr* 90 (2009), 116–123. PMID: [19439459](#) (cited on p. 280).
- [92] A. Hamid, N. A. Wani, and J. Kaur. "New perspectives on folate transport in relation to alcoholism-induced folate malabsorption—association with epigenome stability and cancer development". *FEBS J* 276 (2009), 2175–2191. PMID: [19292860](#) (cited on p. 281).
- [93] K. E. McMartin and T. D. Collins. "Relationship of alcohol metabolism to folate deficiency produced by ethanol in the rat". *Pharmacol Biochem Behav* 18 Suppl 1 (1983), 257–262. PMID: [6634838](#) (cited on p. 281).
- [94] O. V. Fernando and E. W. Grimsley. "Prevalence of folate deficiency and macrocytosis in patients with and without alcohol-related illness". *South Med J* 91 (1998), 721–725. PMID: [9715215](#) (cited on p. 281).
- [95] A. Chan *et al.* "Cobinamide is superior to other treatments in a mouse model of cyanide poisoning". *Clin Toxicol (Phila)* 48 (2010), 709–717. PMID: [20704457](#) (cited on p. 283).

- [96] K. Fujii, T. Nagasaki, and F. M. Huennekens. "Accumulation of 5-methyltetrahydrofolate in cobalamin-deficient L1210 mouse leukemia cells". *J Biol Chem* 257 (1982), 2144–2146. PMID: [7061412](#) (cited on p. 284).
- [97] S.-X. Li *et al.* "Octameric structure of the human bifunctional enzyme PAICS in purine biosynthesis". *J Mol Biol* 366 (2007), 1603–1614. PMID: [17224163](#) (cited on p. 293).
- [98] G. Van den Berghe *et al.* "The purine nucleotide cycle and its molecular defects". *Prog Neurobiol* 39 (1992), 547–561. PMID: [1529104](#) (cited on p. 294).
- [99] N. Zöllner and W. Gröbner. "Dietary feedback regulation of purine and pyrimidine biosynthesis in man". *Ciba Found Symp* (1977), 165–178. PMID: [245992](#) (cited on p. 296).
- [100] W. Löffler *et al.* "Influence of dietary purines on pool size, turnover, and excretion of uric acid during balance conditions. Isotope studies using ¹⁵N-uric acid". *Res Exp Med (Berl)* 181 (1982), 113–123. PMID: [6294765](#) (cited on pp. 296, 302).
- [101] A. Enomoto *et al.* "Molecular identification of a renal urate anion exchanger that regulates blood urate levels". *Nature* 417 (2002), 447–452. PMID: [12024214](#) (cited on p. 299).
- [102] D. I. Feig *et al.* "Hypothesis: Uric acid, nephron number, and the pathogenesis of essential hypertension". *Kidney Int* 66 (2004), 281–287. PMID: [15200435](#) (cited on p. 300).
- [103] I. Ramazzina *et al.* "Completing the uric acid degradation pathway through phylogenetic comparison of whole genomes". *Nat Chem Biol* 2 (2006), 144–148. PMID: [16462750](#) (cited on p. 300).
- [104] W. L. Nyhan. "Dopamine function in Lesch-Nyhan disease". *Environ Health Perspect* 108 Suppl 3 (2000), 409–411. PMID: [10852837](#) (cited on p. 301).
- [105] G. R. Breese *et al.* "A dopamine deficiency model of Lesch-Nyhan disease—the neonatal-6-OHDA-lesioned rat". *Brain Res Bull* 25 (1990), 477–484. PMID: [2127238](#) (cited on p. 301).
- [106] H. K. Choi *et al.* "Alcohol intake and risk of incident gout in men: a prospective study". *Lancet* 363 (2004), 1277–1281. PMID: [15094272](#) (cited on p. 302).
- [107] M. Kishibe, H. Sakai, and H. Iizuka. "Chronic tophaceous gout secondary to self-induced vomiting in anorexia nervosa". *J Dermatol* 37 (2010), 578–580. PMID: [20536680](#) (cited on p. 302).
- [108] D. L. Mehlhaff and D. S. Stein. "Gout secondary to ritonavir and didanosine". *AIDS* 10 (1996), p. 1744. PMID: [8970701](#) (cited on p. 303).
- [109] P. U. Heuckenkamp and N. Zöllner. "Fructose-induced hyperuricaemia". *Lancet* 1 (1971), 808–809. PMID: [4101315](#) (cited on p. 303).
- [110] H. K. Choi and G. Curhan. "Soft drinks, fructose consumption, and the risk of gout in men: prospective cohort study". *BMJ* 336 (2008), 309–312. PMID: [18244959](#) (cited on p. 303).
- [111] R. D. Oberhaensli *et al.* "Study of hereditary fructose intolerance by use of 31P magnetic resonance spectroscopy". *Lancet* 2 (1987), 931–934. PMID: [2889861](#) (cited on p. 303).
- [112] P. Richette *et al.* "Rasburicase for tophaceous gout not treatable with allopurinol: an exploratory study". *J Rheumatol* 34 (2007), 2093–2098. PMID: [17896799](#) (cited on p. 305).

Bibliography

- [113] M. Tamba and A. Torreggiani. "A pulse radiolysis study of carnosine in aqueous solution". *Int J Radiat Biol* 74 (1998), 333–340. PMID: [9737536](#) (cited on p. 307).
- [114] A. A. Boldyrev. "Carnosine: new concept for the function of an old molecule". *Biochemistry (Mosc)* 77 (2012), 313–326. PMID: [22809149](#) (cited on p. 307).
- [115] A. A. Boldyrev, G. Aldini, and W. Derave. "Physiology and pathophysiology of carnosine". *Physiol Rev* 93 (2013), 1803–1845. PMID: [24137022](#) (cited on p. 308).
- [116] C. M. Galmarini *et al.* "In vivo mechanisms of resistance to cytarabine in acute myeloid leukaemia". *Br J Haematol* 117 (2002), 860–868. PMID: [12060121](#) (cited on p. 315).
- [117] S. D. Cline and N. Osheroff. "Cytosine arabinoside lesions are position-specific topoisomerase II poisons and stimulate DNA cleavage mediated by the human type II enzymes". *J Biol Chem* 274 (1999), 29740–29743. PMID: [10514448](#) (cited on p. 316).
- [118] T. F. Cummings. "The treatment of cyanide poisoning". *Occup Med (Lond)* 54 (2004), 82–85. PMID: [15020725](#) (cited on p. 322).
- [119] E. K. Jaffe. "The porphobilinogen synthase catalyzed reaction mechanism". *Bioorg Chem* 32 (2004), 316–325. PMID: [15381398](#) (cited on p. 324).
- [120] A. L. Herrick and K. E. L. McColl. "Acute intermittent porphyria". *Best Pract Res Clin Gastroenterol* 19 (2005), 235–249. PMID: [15833690](#) (cited on p. 327).
- [121] W. E. Müller and S. H. Snyder. "Delta-aminolevulinic acid: influences on synaptic GABA receptor binding may explain CNS symptoms of porphyria". *Ann Neurol* 2 (1977), 340–342. PMID: [214024](#) (cited on p. 330).
- [122] S. Onishi *et al.* "Metabolism of bilirubin and its photoisomers in newborn infants during phototherapy". *J Biochem* 100 (1986), 789–795. PMID: [3782069](#) (cited on p. 333).
- [123] T. Christensen *et al.* "Cells, bilirubin and light: formation of bilirubin photoproducts and cellular damage at defined wavelengths". *Acta Paediatr* 83 (1994), 7–12. PMID: [8193477](#) (cited on p. 333).
- [124] H. Job, G. Hart, and G. Lealman. "Improvements in long term phototherapy for patients with Crigler-Najjar syndrome type I". *Phys Med Biol* 41 (1996), 2549–2556. PMID: [8938045](#) (cited on p. 333).
- [125] A. Kappas, G. S. Drummond, and T. Valaes. "A single dose of Sn-mesoporphyrin prevents development of severe hyperbilirubinemia in glucose-6-phosphate dehydrogenase-deficient newborns". *Pediatrics* 108 (2001), 25–30. PMID: [11433050](#) (cited on p. 334).
- [126] M. Ekroos and T. Sjögren. "Structural basis for ligand promiscuity in cytochrome P450 3A4". *Proc Natl Acad Sci U S A* 103 (2006), 13682–13687. PMID: [16954191](#) (cited on p. 344).
- [127] J. R. Rashid, Kofi-Tsepko, and F. D. Juma. "Acetylation status using hydralazine in African hypertensives at Kenyatta National Hospital". *East Afr Med J* 69 (1992), 406–408. PMID: [1396201](#) (cited on p. 349).
- [128] K. Golka *et al.* "The enhanced bladder cancer susceptibility of NAT2 slow acetylators towards aromatic amines: a review considering ethnic differences". *Toxicol Lett* 128 (2002), 229–241. PMID: [11869833](#) (cited on p. 350).

- [129] R. J. Knox *et al.* "Bioactivation of CB 1954: reaction of the active 4-hydroxylamino derivative with thioesters to form the ultimate DNA-DNA interstrand crosslinking species". *Biochem Pharmacol* 42 (1991), 1691-1697. PMID: [1930294](#) (cited on p. 352).
- [130] V. Favaudon. "On the mechanism of reductive activation in the mode of action of some anticancer drugs". *Biochimie* 64 (1982), 457-475. PMID: [6181817](#) (cited on p. 352).
- [131] E. M. Welch *et al.* "PTC124 targets genetic disorders caused by nonsense mutations". *Nature* 447 (2007), 87-91. PMID: [17450125](#) (cited on p. 357).
- [132] T. Goldmann *et al.* "A comparative evaluation of NB30, NB54 and PTC124 in translational read-through efficacy for treatment of an USH1C nonsense mutation". *EMBO Mol Med* 4 (2012), 1186-1199. PMID: [23027640](#) (cited on p. 357).
- [133] E. Kerem *et al.* "Effectiveness of PTC124 treatment of cystic fibrosis caused by nonsense mutations: a prospective phase II trial". *Lancet* 372 (2008), 719-727. PMID: [18722008](#) (cited on p. 358).
- [134] N. Brunetti-Pierri. "Gene therapy for inborn errors of liver metabolism: progress towards clinical applications". *Ital J Pediatr* 34 (2008), p. 2. PMID: [19490653](#) (cited on p. 359).
- [135] H. L. Elford and A. L. Lin. "Adenosine deaminase impairment and ribonucleotide reductase in human cells". *Ann N Y Acad Sci* 451 (1985), 98-112. PMID: [3907454](#) (cited on p. 359).
- [136] P. Benveniste and A. Cohen. "p53 expression is required for thymocyte apoptosis induced by adenosine deaminase deficiency". *Proc Natl Acad Sci U S A* 92 (1995), 8373-8377. PMID: [7667298](#) (cited on p. 359).
- [137] M. L. Joachims *et al.* "Inhibition of deoxynucleoside kinases in human thymocytes prevents dATP accumulation and induction of apoptosis". *Nucleosides Nucleotides Nucleic Acids* 27 (2008), 816-820. PMID: [18600545](#) (cited on p. 361).
- [138] J. Wen *et al.* "Adenosine deaminase enzyme therapy prevents and reverses the heightened cavernosal relaxation in priapism". *J Sex Med* 7 (2010), 3011-3022. PMID: [19845544](#) (cited on p. 361).
- [139] A. L. Burnett and T. J. Bivalacqua. "Glucose-6-phosphate dehydrogenase deficiency: an etiology for idiopathic priapism?" *J Sex Med* 5 (2008), 237-240. PMID: [17971109](#) (cited on p. 361).
- [140] S. H. Polmar *et al.* "Enzyme replacement therapy for adenosine deaminase deficiency and severe combined immunodeficiency". *N Engl J Med* 295 (1976), 1337-1343. PMID: [980079](#) (cited on pp. 361, 362).
- [141] H. B. Gaspar. "Bone marrow transplantation and alternatives for adenosine deaminase deficiency". *Immunol Allergy Clin North Am* 30 (2010), 221-236. PMID: [20493398](#) (cited on p. 362).
- [142] S. Jevsevar, M. Kunstelj, and V. G. Porekar. "PEGylation of therapeutic proteins". *Biotechnol J* 5 (2010), 113-128. PMID: [20069580](#) (cited on p. 362).
- [143] A. Aiuti *et al.* "Gene therapy for immunodeficiency due to adenosine deaminase deficiency". *N Engl J Med* 360 (2009), 447-458. PMID: [19179314](#) (cited on p. 362).
- [144] C. I. van Capelle *et al.* "Effect of enzyme therapy in juvenile patients with Pompe disease: a three-year open-label study". *Neuromuscul Disord* 20 (2010), 775-782. PMID: [20817528](#) (cited on p. 364).

Bibliography

- [145] P. Ghosh, N. M. Dahms, and S. Kornfeld. "Mannose 6-phosphate receptors: new twists in the tale". *Nat Rev Mol Cell Biol* 4 (2003), 202-212. PMID: [12612639](#) (cited on p. 365).
- [146] A. J. McVie-Wylie *et al.* "Biochemical and pharmacological characterization of different recombinant acid α -glucosidase preparations evaluated for the treatment of Pompe disease". *Mol Genet Metab* 94 (2008), 448-455. PMID: [18538603](#) (cited on p. 366).
- [147] J. A. Barranger and E. O'Rourke. "Lessons learned from the development of enzyme therapy for Gaucher disease". *J Inherit Metab Dis* 24 Suppl 2 (2001), 89-96. PMID: [11758684](#) (cited on p. 367).
- [148] J. K. Amory *et al.* "Miglustat has no apparent effect on spermatogenesis in normal men". *Hum Reprod* 22 (2007), 702-707. PMID: [17067996](#) (cited on p. 368).
- [149] L. de Meis *et al.* "Fusion of the endoplasmic reticulum and mitochondrial outer membrane in rats brown adipose tissue: activation of thermogenesis by Ca^{2+} ". *PLoS One* 5 (2010), e9439. PMID: [20209153](#) (cited on p. 373).

Index

- ABC transporters
 - bile acid transport, 189
 - deficiencies
 - Dubin-Johnson syndrome, 190
 - sitosterolemia, 203–204
 - Tangier disease, 203
 - sterol transport, 184, 187
 - structure and function, 185–186
- ACAT, *see* acyl-CoA cholesterol acyltransferase
- acetaminophen, metabolism, 348
- acetoacetate
 - decarboxylation, 161–162
 - leucine degradation, 222
 - mitochondrial acetyl-CoA export, 168
 - synthesis, 161
- acetone
 - anticonvulsant activity, 163
 - metabolism, 161–163
 - substrate for gluconeogenesis, 162–163
- acetyl-CoA
 - formation by pyruvate
 - dehydrogenase, 58, 61
 - glyoxylate cycle, 170–171
 - mitochondrial export, 167–168
 - oxidation, *see* citric acid cycle
- acetyl-CoA carboxylase, 164
- acetylphosphate, 40
- aciclovir, 316–317
- acid maltase, 121
 - deficiency, 127
 - enzyme therapy, 364
- acid-base catalysis, 36–37
- activation energy (ΔG^*), 20
- active transport
 - glucose, 14
- acute intermittent porphyria, 329–330
- acute myeloid leukemia (AML), 315
- acute urate nephropathy, 304–305
- acyl carrier protein, 165*n*
- acyl thiokinase, 154
- acyl-CoA cholesterol acyltransferase, 183
- acyl-CoA dehydrogenase, 155
- acyl-CoA synthetase, *see* acyl thiokinase
- adenine phosphoribosyltransferase (APRT), 300
- adenosine deaminase, 297
- adenosine deaminase deficiency, 301
 - bone marrow transplant, 360
 - enzyme therapy, 361–362
 - experimental drug treatment, 360–361
 - gene therapy, 362–363
 - pathogenesis, 359–360
- adenosine kinase, 300

Index

- adenosine monophosphate (AMP)
 - deaminase, 297, 298
- adenosine monophosphate (AMP)
 - synthesis, 293-294
- adenylate cyclase, 110, 158
 - inhibition by metformin, 267
- adenylate kinase, 23-24, 303
- adenylosuccinate lyase, 291, 293
- AICAR, *see* purine nucleotide synthesis
- albumin
 - osmotic activity, 152
 - transport of free fatty acids, 158
- alcohol dehydrogenase, 19, 107
 - acetone breakdown, 163
- aldehyde dehydrogenase, 107
 - acetone breakdown, 163
- aldolase, 34
- aldolase B, 48, 303
 - deficiency (fructose intolerance), 49
- aldose reductase, 54
 - inhibitors, in diabetes, 263
- allantoin, 299
- allopurinol, 303, 313
- amino acids
 - conjugation, 350
 - degradation
 - asparagine, 220
 - glycine, 272
 - histidine, 273
 - leucine, 221-222
 - overview, 208-209
 - phenylalanine, tyrosine, 222-223
 - serine, 220-221, 271
 - metabolic uses, 207
 - transamination
 - mechanism, 210-211
 - overview, 209-210
- aminoacrylate, 220
- 5'-aminoimidazole ribotide synthetase, 291
- aminoimidazole-carboxamido-ribotide (AICAR) transformylase, 292
- aminoxyacetate, 93
- aminotransferases, *see* amino acids, transamination
- ammonia
 - carbamoylphosphate synthesis, 212
 - nitrogen fixation, 4
 - release and scavenging in the liver
 - lobule, 217-218
 - urinary excretion, 212*n*
- AMP-activated kinase, 267
- amphibolic
 - definition, 3
- amylase, 13-14
- amylopectin, 13
- amylose, 13
- anabolic
 - definition, 2
- anaerobic glycolysis, *see* glycolysis, anaerobic
- anemia
 - hemolytic, in glucose-6-phosphate dehydrogenase deficiency, 142
 - microcytic hypochromic, 327
- anorexia nervosa, 302
- apolipoproteins, 182
- apoptosis, 78*n*, 351, 359
- araC, *see* cytosine arabinoside
- archaeobacteria, 4
- arginase, 213
- arginine deficiency, in ure cycle enzyme defects, 219
- argininosuccinase, 213
- argininosuccinate synthetase, 213
- asparaginase, 220
- asparagine synthetase, 220
- aspartate aminotransferase, 93, 213
- aspartate transcarbamylase, 306
- ataluren, 356-358
- atherosclerosis
 - and hypercholesterolemia, 190-191
 - blood clot formation, 191
 - metabolic aspects, 194
 - role of oxidized LDL, 198
 - vascular lesions
 - morphology, 191-192
 - pathogenesis, 193
- atorvastatin, 199
- ATP
 - hydrolysis, 35
 - role in enzyme reactions, 22
- ATP synthase
 - binding-change model, 89-90
 - driven by proton flux, 90-92
 - structure, 88-89
- ATP-citrate lyase, 167
- ATP/ADP transporter, mitochondrial, 98
- autotrophic
 - definition, 3
- bacteriorhodopsin, 74

- baker's yeast, 41
Banting, Frederick, 231
benzbromarone, 303
Best, Charles, 231
 β -alanine, 307
 β -oxidation
 reaction mechanisms, 156-157
 reactions, 155
 β -hydroxybutyrate
 synthesis, 161
Bethune, Norman, 232
bezafibrate, 201
bile acids, 11-12
 absorbers, for lowering cholesterol, 201
 enterohepatic cycle, 189
 structure, 188
bilirubin
 conjugation and deconjugation, 330
 photoisomerization, 333
bilirubin encephalopathy, 332
biliverdin, 330
biotin
 leucine degradation, 222
 malonyl-CoA carboxylase, 164
 pyruvate carboxylase, 104
1,3-bis-phosphoglycerate, 34, 40
branched chain α -keto acid
 dehydrogenase, 221
branched chain amino acid transaminase, 221
branching enzyme, 117
5-bromouracil-deoxyriboside (5-BUdR), 312
brown fat tissue, 73, 159

C-peptide, 233
canfosamide, 353
carbamoylphosphate synthetase
 pyrimidine nucleotide synthesis, 306
 urea cycle, 212
carbon monoxide, putative signaling function, 334
4'-carboxy-5'-aminoimidazole ribotide
 carboxylase, 291, 292
carboxyphosphate, 104
carnitine, 153
carnosine, 307-308
catabolism
 definition, 2
 overview, 5-6
catalytic triad, *see* chymotrypsin, catalytic mechanism
cataract
 in diabetes, 54
 in type II galactosemia, 53
CB 1954, 352
cerulenine, 169
cholecalciferol, 178
cholesterol
 biological functions, 173
 intestinal uptake, 183-184
 therapeutic inhibition, 199-200
 metabolism, as a therapeutic target, 198-199
 synthesis
 overview, 174-175
 reactions, 175-178
 regulation, 179-182
 transport by lipoproteins, 186-188
 turnover, processes involved in, 174
cholesterol ester transfer protein, 200
cholestyramine, 201
chylomicrons
 disposal, 153
 synthesis and transport, 150-152
 vs. other lipoproteins, 183
chymotrypsin
 catalytic mechanism, 17-18
cidofovir, 318
citrate isomerase, 65
citrate synthase, 64
 mitochondrial acetyl-CoA export, 167
citric acid cycle, 63-68
 overall reaction, 64
 reactions, 64-66
 regulation, 67-68
 replenishment of intermediates, 68
citrulline
 nitric oxide synthase, 140
 urea cycle, 213
cobalamin
 deficiency
 causes, 283
 treatment, 283
 in cyanide poisoning, 283
 intestinal uptake, 282
 methionine synthesis, 276
 structure, 275-276
coenzyme Q, 76, *see also* Q cycle
coenzymes

Index

- role in catalysis, 19
- coproporphyrinogen III, 326
- Cori cycle, 125-126
- covalent catalysis, 37-38
- coxsackievirus, and type 1 diabetes, 256
- Crigler-Najjar syndrome, 332
- Crohn's disease, 283
- cyanide poisoning, 322*n*
 - cobalamin treatment, 283
- cyclic AMP (cAMP)
 - dysregulation in diabetes mellitus, 252
 - regulation of gluconeogenesis, 109-111
 - regulation of glycogen metabolism, 122-123
- cyclic GMP (cGMP), 140
- cystic fibrosis, 357-358
- cytarabine, *see* cytosine arabinoside
- cytochrome C, 76, 78, 84
- cytochrome C oxidase, 76
 - reaction mechanism, 84-85
- cytochrome P450
 - acetone metabolism, 162
 - in drug metabolism, 341-345
 - prominent role of CYP3A4, 342
 - structure, 343
 - toxification of benzopyrene, 346
 - transcriptional induction, 342-343
- cytochrome P450 reductase, 350
- cytosine arabinoside, 313-316

- dalcetrapib, 200
- debranching enzyme, 119, 120
- 7-dehydrocholesterol, 178
- ΔG and ΔG^* , in enzyme reactions, 20
- δ -aminolevulinic synthase, 323
- 5-deoxyadenosine, 360
- deoxycytidine kinase, 361
- deoxyribonucleotide synthesis, 308-309
- deoxyribose phosphate aldolase, 297
- desaturases, 168-169
- dexamethasone, 245
- diabetes
 - type 2
 - sulfonylurea drugs, 236
- diabetes insipidus, 247*n*
- diabetes mellitus
 - aldose reductase inhibitors, 263
 - cataract, 262
 - clinical symptoms, 255
 - complications
 - long term, 262-263
 - short term, 262
 - dysregulation of glucose metabolism, 252
 - dysregulation of lipid and protein metabolism, 253-254
 - etymology, 247
 - forms, 248
 - hyperglycemia, 262
 - hypoglycemia, 262
 - insulin therapy, intensive, 263-265
 - laboratory findings, 254-255
 - oral antidiabetics, 265-266
 - renal glucose loss, 251-252
 - therapy
 - acute case, 259
 - type 1, pathogenesis, 256-258
- diaphorase, 350, 352
- dideoxyadenosine, 316
- digestion
 - bile, role of, 11-12
 - enzymes, 11
 - overview, 5-6
- digestive system, 6-15
- dihydrofolate reductase, 312
 - inhibitors
 - antimicrobials, 275
 - reactions, 270
- dihydroorotate, 306
- dihydroxyacetone phosphate, 34, 48
 - glycerophosphate shuttle, 93
- 1,25-dihydroxycholecalciferol, 178
- dimethylallyl-pyrophosphate, 175
- dinitrophenol, 73-74
- diphosphomevalonate decarboxylase, 175
- DNA polymerase, inhibitors, 315-318
- DNA topoisomerase, 315
- drug metabolism
 - active metabolites, 345
 - conjugation reactions, 346-350
 - overview, 339
 - phase I, II, and III, 340-341
 - reductive, 350-351
- Dubin-Johnson syndrome, 190

- earthquakes, 178
- eliglustat, 368
- elongases, 168-169
- endoplasmic reticulum

- smooth
 - sterol metabolism, 179
- energy-rich bonds and functional groups, 39–40
- enolase, 34
- enoyl-CoA hydratase, 155
- enoylreductase, *see* fatty acid synthase, reactions
- enzyme activity
 - allosteric regulation, 25
 - and cooperativity, 26–27
 - control by phosphorylation, 26
 - transcriptional control, 28
- enzyme defects, *see also* specific enzymes
- enzyme therapy
 - adenosine deaminase deficiency, 361–362, 366–367
 - Pompe disease, 364
- gene therapy
 - adenosine deaminase deficiency, 362–363
 - technical considerations, 358–359
- lysosomal, enzyme therapy, 363–367
- therapeutic options, 355–356
- enzymes, IUBMB classification, 19–20
- epinephrine
 - gluconeogenesis, 109–110
 - glycogen metabolism, 122–123
 - hormone-sensitive lipase, 158
 - signaling mechanism, 241–242
- epoxide hydrolase, 347
- equilibrative nucleoside transporter (ENT), 314
- erythromycin, 343
- erythrose-4-phosphate, 133
- essential fatty acids, 169
- ethanol
 - degradation, 107
 - folate deficiency, 281
- ethanolic fermentation, 41–42
- ezetimibe, 199
- Faraday's constant, 80
- farnesyl-pyrophosphate
 - cholesterol synthesis, 176
- fast acetylators, 349–350
- fat tissue
 - white and brown, 159
- fatty acid synthase
 - pharmacological inhibition, 169–170
 - reactions, 165–167
 - structure and catalytic activities, 164–165
- fatty acids
 - common variants, 149
 - elongation and desaturation, 168–169
 - essential, 149*n*, 169
 - mitochondrial transport, 153–154
 - synthesis
 - overview, 164
 - reactions, 164–167
 - utilization, 153–155
 - odd-numbered chain lengths, 157
- favism, 142–144
- ferritin, 336–337
- ferrochelataase, 326
- flavin adenine dinucleotide (FAD), 65, 77
- flavin mononucleotide (FMN), 77
- flavine adenine nucleotide (FAD), 155
- 5-fluorouracil, 310–312
- foam cells, 192
- folic acid
 - antimetabolites
 - antimicrobials, 274–275
 - deficiency, 280–282
 - uptake and storage, 280
- foodstuffs
 - energy contents, 147
 - types, 4–5
- formic acid, 51
- formylglycinamidine ribotide synthetase, 291
- foscarnet, 317
- free energy (ΔG), 20
- fructokinase, 48, 303
- fructolysis, *see* fructose degradation
- fructose
 - and obesity, 49
 - degradation, 48–49
 - hyperuricemia, 303
 - in sperm fluid, 54
 - intolerance, 49
- fructose-1-phosphate, 48
- fructose-1,6-bisphosphatase, 105
 - putative role in hexose
 - monophosphate shunt, 134
 - regulation, 109
- fructose-1,6-bisphosphate, 34
- fructose-2,6-bisphosphate

Index

- regulation of gluconeogenesis, 109-111
- fructose-6-phosphate, 34
 - hexose monophosphate shunt, 133
- β -fructosidase, 48
- fumarase, 66
- fumarate
 - citric acid cycle, 65
- futile cycles, *see* substrate cycles
- G protein coupled receptors, 241-242
- galactitol, 54
- galactokinase, 50, 53
- galactose
 - degradation, 50-51
 - enzyme defects, *see* galactosemia
- galactose epimerase
 - reaction mechanism, 51
- galactose-1-phosphate, 50, 52
- galactose-1-phosphate uridylyltransferase, 50, 52
- galactosemia, 52-53
- β -galactosidase, 50, 52
- γ -aminobutyrate (GABA), 330
- ganciclovir, 316
- gastric acid, 9
- gastric lipase, 150, 160
- Gaucher disease, 366-368
 - drug treatment, 368
- geranyl-pyrophosphate synthase, 175
- Gilbert's syndrome, 332
- glucacon
 - signaling mechanism, 241-242
- glucagon, 230
 - gluconeogenesis, 109-110
 - glycogen metabolism, 122-123
 - hormone-sensitive lipase, 158
- glucocerebrosidase, 366-367
 - partial deglycosylation for enzyme therapy, 367
- glucocorticoids
 - metabolic effects, 244
 - receptor agonists and antagonists, 245
 - signaling mechanism, 243-244
- glucokinase, 43-44
- gluconeogenesis
 - energy balance, 105-106
 - inhibition by ethanol, 107
 - metabolic connections, 106
 - mitochondrial transport in, 106-107
 - overview, 101-102
 - reactions, 102-105
 - regulation, 108-111
 - hormones, 109-110
- gluconolactonase, 133
- glucose
 - active transport, 14
 - anomers, 33
 - degradation
 - ATP yield, 97-99
 - overview, 31-32
 - GLUT transporters, 14
 - regulation by insulin, 239-240
 - subtypes and kinetics, 42-43
 - intestinal uptake, 14
 - organ-specific utilization, 42-44
- glucose alanine cycle, 215
- glucose-1-phosphate, 50, 119
- glucose-6-phosphatase, 105
 - deficiency, 126-127
 - expression in muscle, 125
 - glycogen degradation, 120
 - regulation, 109
- glucose-6-phosphate, 34
 - glycogen degradation, 120
 - hexose monophosphate shunt, 132
 - in galactose degradation, 50
- glucose-6-phosphate dehydrogenase
 - deficiency, 142-144
 - neonatal jaundice, 334
 - reaction, 132
- glucosylceramide, 366
- GLUT transporters, *see under* glucose
- glutamate
 - in nitrogen disposal, 216-217
 - in transamination, 209
 - malate-aspartate shuttle, 93
- glutamate dehydrogenase, 212, 216
- glutaminase, 217-218
 - regulation, 218
- glutamine
 - as a nitrogen carrier, 215-216
- glutamine synthetase, 22, 217-218
- glutamine-PRPP-amidotransferase, 291
- glutathione
 - peroxidase, 143
 - scavenging of reactive oxygen species, 141-142
- glutathione-S-transferase, 347
- glyceraldehyde, 48
 - kinase, 48

- glyceraldehyde-3-phosphate, 34
 hexose monophosphate shunt, 133
- glyceraldehyde-3-phosphate dehydrogenase, 34
 in apoptosis, 78*n*
 reaction mechanism, 37–38
- glycerol, 49
- glycerol-1-phosphate, 49
- glycerophosphate shuttle, 93–94
- glycinamide ribotide synthetase, 291
- glycinamide ribotide transformylase, 291
- glycine cleavage system, 272
- glycogen
 α and β particles, 115
 degradation, 119–121
 lysosomal, 121
 metabolism
 liver vs. muscle, 123–125
 overview, 113–114
 regulation, 121–123
 structure, 113–116
 synthesis, 116–119
- glycogen phosphorylase, 119
 allosteric regulation, 122
 liver and muscle isoforms, 123
 muscle
 deficiency, 127–128
 reaction mechanism, 120–121
- glycogen storage diseases, 126–128
- glycogen synthase, 117–119
 regulation, 122, 238
- glycogen synthase kinase 3, 238
- glycogenin, 117
- glycolysis, 31–44
 anaerobic
 ATP yield, 40
 cell types, 34
 reactions, 33–34
 reversible and irreversible reactions, 34
- glyoxylate cycle, 170–171
- gout, 302–304
 dietary factors, 302
- guanase, 297, 298
- guano, 4*n*
- guanosine kinase, 300
- guanosine monophosphate (GMP)
 synthesis, 294
- guar gum, 202
- Guthrie test, 224–225
- Haber-Bosch process, 4*n*
- haptocorrin, 282
- haptoglobin, 198
- HbA_{1C}, 263
- HDL, *see* high density lipoprotein
- Helicobacter pylori*, 10
- heme
 biosynthesis, 322–327
 crystallization in malaria parasites, 143
 functions, 322
 respiratory chain cofactors, 77
- heme biosynthesis
 disruptions (overview), 327
- heme degradation, 330–335
- heme oxygenase, 330
- hemochromatosis, 329
- hemosiderin, 337
- heterotrophic
 definition, 3
- hexokinase, 34
 and glucokinase, 43–44
 reaction mechanism, 35–36
- hexose monophosphate shunt
 homologous sugar series, 134–135
 overview, 131–132
 reactions, 132–134
- hibernating animals, 159
- high density lipoprotein, 183, 187
- Hitchhiker's Guide to the Galaxy, 198
- HLA molecules, 257–258
- homogentisate dioxygenase, 223
- hormonal regulation
 overview, 229
- hormone-sensitive lipase, 158
- Howard Hughes, 1
- human immunodeficiency virus (HIV), 316
- human leukocyte antigens, *see* HLA molecules
- hydroxyacyl dehydratase, *see* fatty acid synthase, reactions
- hydroxyacyl-CoA dehydrogenase, 155
- hydroxybutyrate dehydrogenase, 161
- hydroxymethylbilane synthase, 325
- hydroxymethylglutaryl-CoA lyase, 161, 222
- hydroxymethylglutaryl-CoA reductase
 reaction, 175
 regulation, 179
 therapeutic inhibition, 199

Index

- hydroxymethylglutaryl-CoA synthase
 - cholesterol synthesis, 175
 - ketone body synthesis, 161
- p*-hydroxyphenylpyruvate dioxygenase, 223
 - therapeutic inhibition in tyrosinemia, 227
- hydroxypyruvate, 221
- hypercholesterolemia
 - familial, 202
 - induction of atherosclerosis, 190-191
- hyperlipidemia
 - glucose-6-phosphatase deficiency, 126
- hyperuricemia, *see also* gout, 302
 - drug-induced, 304
 - glucose-6-phosphatase deficiency, 126
 - Lesch-Nyhan syndrome, 301
- hypoglycemia
 - ethanol-induced, 107
 - glucose-6-phosphatase deficiency, 126
 - in vitamin B₁₂ deficiency, 107
- hypoxanthine, 292, 299
- hypoxanthine-guanine
 - phosphoribosyltransferase (HGPRT), 300
 - deficiency, 301
- idoxuridine, 312
- inflammasomes, 193
- inosine kinase, 300
- inosine monophosphate (IMP), 290, 294
- inosine monophosphate (IMP)
 - dehydrogenase, 297, 298
- inosine monophosphate cyclohydrolase, 292
- INSIG, 180
- insulin
 - aggregation, 260-261
 - biphasic preparations, 261-262
 - discovery, 230-231
 - gluconeogenesis, 109-110
 - glucose transport, 239-240
 - glycogen metabolism, 122-123, 238
 - mutants, for intensive therapy, 264-265
 - primary structure, 232-234
 - protamine complex, 261
 - secretion
 - regulation, 234-235
 - secretion, kinetics, 259-260
 - transcriptional regulation, 240
- insulin receptor
 - signaling mechanism, 237
- intelligent design, 97
- intestinal organs, *see also* stomach, liver, etc., 6-7
- intestine, large, 15
- intestine, small
 - structure, 12
- intrinsic factor, 282
- iron depletion, 327, 335
- iron overload, 337
- iron uptake and storage, 335-337
- iron-sulfur clusters, 77
- isocitrate, 65
- isocitrate dehydrogenase, 65
 - NAD- and NADP-dependent isoforms, 67-68, 95-97
- isocitrate lyase, 171
- isomaltose, 13
- isoniazid, metabolism, 349-350
- isopentenyl-CoA, 222
- isopentenyl-pyrophosphate isomerase, 175
- isouramil, 143
- isovaleryl-CoA, 222
- isozymes, 123
- IUBMB classification of enzymes, 19-20
- jaundice
 - causes, 331-332
 - neonatal, 332-334
 - phototherapy, 333
- kernicterus, 332
- ketoacidosis, 255
- ketoacyl reductase, *see* fatty acid synthase, reactions
- ketoacyl synthase, *see* fatty acid synthase, reactions
- ketoconazole, 344
- ketogenic diet, 163
- α -ketoglutarate
 - citric acid cycle, 65
 - in transamination, 209
- α -ketoglutarate dehydrogenase, 65
 - reaction mechanism, 66-67
- α -ketoisocaproate, 221

- ketone body metabolism
dysregulation in diabetes, 254
overview, 160–161
reactions, 161–163
- kidneys
function, overview, 248–249
glomerular filtration, 250–251
loss of glucose in diabetes, 251–252
tissue structure, 249–250
tubular reuptake and secretion, 251
- lactase, *see* β -galactosidase
- lactate, 34
anaerobic exercise, 126
blood level, 41*n*
muscle glycogen utilization, 125
- lactate dehydrogenase, 34, 40–41
- lactic acidosis, 93, 255*n*
- lactose
degradation, 50–51
intolerance, 51–52
structure, 50
- lactose intolerance, 51
- Lafora disease, 128
- Langerhans islets, 230
- lanosterol, 177
- LDL, *see* low density lipoprotein
- LDL apheresis, 201
- lead intoxication, 324, 327
- lecithin-cholesterol acetyltransferase, 187–188
- Leloir pathway, *see* galactose degradation
- leptin, 245–246
- Lesch-Nyhan syndrome, 301
- leucine degradation, 221–222
- linoleate, 149
- lipids
types, 147
- lipoamide
in pyruvate dehydrogenase, 59
- lipoprotein lipase, 152–153
- lipoproteins
classification, 183
general structure, 182
- liver
glycogen content, 113
glycogen utilization, 123–124
lobules, 8–9
localized enzyme expression, 217–218
substrate overload in diabetes, 254
- liver cirrhosis, 212*n*
- lomitapide, 200
- lovastatin, 199
- low density lipoprotein, 183
chemical modifications, 194–195
in atherosclerosis, 193
- lymphocytes
anaerobic glycolysis, 34
- macrocytic anemia
folate deficiency, 281–282
in cobalamin deficiency, 284
- macrophages
cholesterol accumulation, 194
conversion to foam cells, 192
production of ROS, 141
- malaria, 143–144
- L-malate, 66
- malate dehydrogenase, 66
regulation of the TCA cycle, 67
- malate synthase, 171
- malate-aspartate shuttle, 92–93
- malate-oxaloacetate shuttle, 92
- maleylacetoacetate isomerase, 223
- malonyl-acetyltransferase, *see* fatty acid synthase, reactions
- maltose, 13
- mannose receptor, 367
- mannose-6-phosphate receptor, 365–366
- Mary Lyon hypothesis, 142
- McArdle's disease, 127–128
- mechlorethamine, 351
- medium-chain fatty acids, 160
- mercaptopurine, 313
- metabolism
autotrophic and heterotrophic, 3
carbon pools, 148
catabolic and anabolic, 2–3
drug targets in, 2
hormonal regulation, overview, 229
in plants and bacteria, 3–4
medical significance, 1
- metformin, 266–267
- methemoglobin reductase, 322, 350, 352
- methotrexate, 312–313
- methyl trap hypothesis, 284
- methylcobalamin, *see* cobalamin
- methylglutaconyl-CoA, 222
- methylmalonyl-CoA racemase, 157
- mevalonate kinase, 175
- mevastatin, 199

Index

- mifepristone, 245
- miglustat, 368
- minimal medium, 225
- mitochondria
 - hydrogen shuttles, 92-94
 - inner and outer membrane, 58
 - proton leak, 87*n*, 95
 - proton-motive force, 87-88
 - transport driven by, 98-99
- mitochondrial triglyceride transfer protein, 183, 200
- mixed acid fermentation, 51
- morphine
 - metabolism, 348-349
- muscle, *see also* skeletal muscle
 - smooth vs. striated, 31
- muscle tissue
 - fatty acid utilization, 158
- myelin, 278-279
- myeloperoxidase, 141, 198

- N,N'*-methylenetetrahydrofolate, *see also* folic acid
 - regeneration, 271-273
- N-acetylglutamate, 218
- N-acetyltransferase 2, 349-350
- NAD
 - and NADP, 39
 - comparison, 137
 - transhydrogenase, 95-97
 - in β -oxidation, 155
 - mitochondrial dehydrogenation of NADH, 82, 266
 - redox mechanism, 38-39
 - reoxidation of NADH under anaerobic conditions, 40-42
- NADPH
 - metabolic uses, overview, 139
 - oxidase, 141
 - regeneration
 - hexose monophosphate shunt, 132-133
 - malic enzyme, 138
 - transhydrogenase, 138-139
- neonatal jaundice, 332-334
- nicotinamide adenine dinucleotide, *see* NAD, NADH
- nicotinamide adenine dinucleotide phosphate, *see* NADP, NADPH
- nicotinamide nucleotide
 - transhydrogenase, 95-97
- nicotinic acid, 201
- nitric oxide
 - signaling effects, 140-141, 335
 - synthase, 140
- 2-[2-nitro-4-(trifluoromethyl)benzoyl]-cyclohexane-1,3-dione, 223, 227
- nitrogen disposal
 - overview, 211-212
 - transport between organs, 215-216
- nitrogen fixation, 3-4
- NPC1L1, 183, 199
- NTBC, 223, 227
- nuclear hormone receptors, 243-244
- nucleic acids
 - dietary, utilization, 295-297
- 5'-nucleotidase, 314-315
- nucleotide antimetabolites, 309-310
- nucleotide synthesis, *see* purine synthesis, pyrimidine synthesis
- nucleotides
 - as part of coenzymes, 287-288
 - biochemical roles, 287
 - dietary, utilization, 295-297
 - pathways
 - overview, 290

- ochratoxin A, 225-226
- oleate, 149
- organic anion transport proteins, 189
- ornithine aminotransferase, 218
- ornithine transcarbamylase, 213
- orotate phosphoribosyltransferase, 306
- orotidine monophosphate (OMP), 306
- osmotic diuresis, 252
- oxaloacetate, 66
 - malate-aspartate shuttle, 93
- oxalosuccinate, 65
- oxidized LDL, 195-196
 - role in atherosclerosis, 198

- P-glycoprotein, 314
- palmitate, 149
 - fatty acid synthesis, 164
- pancreas
 - endocrine, 230
 - exocrine, 11
 - insufficiency, 160
- pancreatic DNase and RNase, 295
- pancreatic lipase, 150
- parietal cells, 283

- pentose phosphate shunt, *see* hexose
 monophosphate shunt
 pentostatin, 361
 PEP, *see* phosphoenolpyruvate
 pernicious anemia, 283
 phagocytes
 production of ROS, 141
 phenobarbital, metabolism, 340
 phenylacetic acid, 350
 phenylalanine degradation, 222-223
 phenylalanine hydroxylase, 222
 deficiency, 224
 phenylbutanoic acid, 350
 phenylketonuria, 224-226
 phosphatidylcholine
 biosynthesis, 277
 LCAT reaction, 187
 sphingomyelin biosynthesis, 278
 phosphatidylethanolamine, 277
 phosphatidylinositol-3-kinase, 238
 phosphodiesterase, 110, 238
 phosphoenolpyruvate, 34, 39, 40
 phosphoenolpyruvate carboxykinase,
 105
 phosphofructokinase, 34
 allosteric regulation, 23-25, 109
 phosphofructokinase 2, 110
 phosphoglucomutase
 galactose degradation, 50
 glycogen degradation, 120
 glycogen synthesis, 116
 6-phosphogluconate, 133
 6-phosphogluconolactone, 132
 phosphoglycerate kinase, 34
 phosphoglycerate mutase, 34
 2-phosphoglycerate, 34
 3-phosphoglycerate, 34
 phosphohexose isomerase, 34
 phosphohexoseisomerase
 reaction mechanism, 36-37
 phosphomevalonate kinase, 175
 phosphopantetheine, 165
 phosphopentomutase, 296
 5'-phosphoribosyl-1'-pyrophosphate, 291,
 306
 phosphoribosylamine, 291, 294
 5'-phosphoribosyl-1'-pyrophosphate, 291
 phosphorylase, *see* glycogen
 phosphorylase
 photosynthesis, 3
 ping pong bi bi enzyme reaction
 mechanism, 211
 plant sterols, 184, 200
 polyol pathway, 53-54
 in diabetic polyneuropathy, 54
 Pompe disease, 127
 enzyme therapy, 364
 porphobilinogen deaminase, 325
 deficiency, 330
 porphobilinogen synthase, 324-325
 porphyria cutanea tarda, 328-329
 prednisolone, 245
 pregnane X receptor, 342
 priapism, 361
 primaquine, 144
 probenecid, 303
 probucol, 201
 propionate
 in β -oxidation, 157
 propionyl-CoA carboxylase, 157
 proteasome, 18
 proteasomes, 28
 protein kinase A, 110, 122, 158, 242
 protein kinase B, 238
 protoporphyrinogen IX, 326
 PRPP, *see* 5'-phosphoribosyl-1'
 -pyrophosphate
 purine nucleoside phosphorylase, 295,
 298
 purine nucleotide cycle, 294
 purine nucleotide degradation, 297-300
 purine nucleotide salvage, 300
 purine nucleotide synthesis
 overview, 290-291
 reactions, 291-294
 regulation, 294-295
 pyrazinamide, metabolites, 304
 pyridoxal phosphate
 amino acid transamination, 210-211
 pyridoxal phosphate
 δ -aminolevulinate synthase, 323
 glycogen phosphorylase, 120
 serine dehydratase, 220
 serine hydroxymethyltransferase,
 271
 pyrimidine nucleoside phosphorylase,
 295, 307
 pyrimidine nucleotide degradation, 307
 pyrimidine nucleotide synthesis,
 305-306
 pyrophosphatase, 117*n*

Index

- pyruvate
 - mitochondrial transport, 58
- pyruvate carboxylase
 - and citric acid cycle, 106
 - mechanism, 103–105
 - role in citric acid cycle, 68
- pyruvate dehydrogenase, 58–63
 - coenzymes, 59–60
 - kinase, 62
 - phosphatase, 63
 - reaction, 58–59
 - reaction mechanisms, 59–61
 - regulation, 62–63
 - subunit structure, 59
- pyruvate kinase, 34
 - reaction mechanism, 39
 - regulation, 111
- Q cycle, 82–84
- Racker experiment, 74–75
- rasburicase, 305
- reactive oxygen species
 - formation by hemoglobin, 322
 - formation in phagocytes, 141
 - formation in the respiratory chain, 78
 - lipid peroxidation, 196–197
 - NADPH and glutathione in scavenging, 141–142
- receptor tyrosine kinases, 237
- red blood cells
 - anaerobic glycolysis, 34
- redox potential
 - and free energy, 80–81
 - measurement, 79–80
- respiratory acidosis, 255*n*
- respiratory chain
 - overview, 71–73
 - protein complexes, 75–77
 - proton pumping
 - mechanism, 85–87
 - stoichiometry, 87
 - redox cofactors, 77–78
 - hydrogen and electron carriers, 82
 - single- and two-electron carriers, 82
 - redox potentials and free energies, 81–82
 - regulation, 94–97
 - uncoupling proteins, 73
- retinoid X receptor, 243
- ribonucleotide reductase, 308
- ribose phosphate diphosphokinase, 291
- ribose-5-phosphate
 - hexose monophosphate shunt, 133
- ribosephosphate diphosphokinase, 313
- ribulose-5-phosphate, 133
 - epimerase, 133
 - isomerase, 133
- ricketts, 178
- RNA world, 288–289
- Rolls Royce, 1
- S*-adenosylhomocysteine, 277
- S*-adenosylmethionine
 - cycle, 276
 - role in biosynthesis, 277
 - structure, 277
- Saccharomyces cerevisiae*, 41
- SAICAR, *see* purine nucleotide synthesis
- salicylic acid, 304
- Sanger, Frederick, 232
- SCAP, 180–182
- scavenger receptor, 194
- sedoheptulose-7-phosphate, 133
- serine dehydratase, 220–221
- serine hydroxymethyltransferase, 271
- serine-pyruvate transaminase, 221
- serotonin, deficit in phenylketonuria, 224
- severe combined immunodeficiency, 360
- Sherlock Holmes, 1
- Sinorhizobium meliloti*, 4
- sitosterol, 200
 - structure, 184
- sitosterolemia, 203–204
- skeletal muscle
 - Cori cycle, 125–126
 - glycogen content, 113
 - glycogen utilization, 124–125
- skin pigmentation, 178
- slow acetylators, 349–350
- smooth muscle, 31*n*
- Sn-mesoporphyrin, 334
- sodium glucose transporter (SGLT1), 14
- sorbitol, 53
- sphingomyelin, 278
- squalene
 - cyclization, 177
 - synthesis, 177
- SREBP, 180–182

- SREBP cleavage activating protein (SCAP), 180–182
- standard hydrogen electrode, 79
- standard redox potential, 80
- statins, 199
- stearate, 149
- sterol response element-binding protein (SREBP), 180–182
- stomach, 9–10
 parietal cells, 283
- striated muscle, 31*n*
- substrate cycles
 in gluconeogenesis, 108–109
 metabolic regulation, 27–28
- succinate, 65
- succinate dehydrogenase, 65
- succinate thiokinase, 65
- succinobucol, 201
- succinyl-aminoimidazole-carboxamido-
 ribotide synthetase, 291
- succinyl-CoA
 propionate utilization, 157
 TCA cycle, 65
- succinyl-CoA mutase, 157
- succinylphosphate, 40
- sucrase, 48
- sucrose
 degradation, 48–49
- sugar beet, 48
- sugar cane, 48
- sulfonamides, 274–275
- sulfonylurea receptor, 234–236
- superoxide, *see* reactive oxygen species
- superoxide dismutase, 141
- T cell receptors, 257
- T lymphocytes, subtypes and functions, 256–258
- Tangier disease, 203
- TCA cycle, *see* citric acid cycle
- tenofovir disoproxil, 318
- terminal ileum
 bile acid reuptake, 189
 cobalamin uptake, 282
- tetrahydrofolate
 role in biosynthesis, 269–271, 274
- thermogenin, 159
- thiamine pyrophosphate
 pyruvate dehydrogenase, 60–61
 transketolase, 135–136
- thioester
 as an energy-rich group, 40
 in the glyceraldehyde-3-phosphate
 dehydrogenase reaction, 38
- thioguanine, 313
- thiolase
 cholesterol synthesis, 175
 reaction mechanism, 156–157
- thiopurine methyltransferase, 313
- thioredoxin, 350
- thrombocytes
 anaerobic glycolysis, 34
- thymidylate synthase, 309, 311
- thyroid hormones
 signaling mechanisms, 243–244
- tocopherol, 197
- tolbutamide, 236
- transaldolase, 133
 reaction mechanism, 136
- transamination, *see* amino acids,
 transamination
 branched chain amino acids, 221
- transcobalamin, 282
- transition state, 20, 22
- transketolase, 133
 IUBMB nomenclature, 20
 reaction mechanism, 135–136
- translational antitermination, 356–358
- triacylglycerol
 digestion and uptake, 149–151
 efficiency of energy storage, 147–148
 solubilization by bile acids, 149–150
 structure, 149
 utilization, organ relationships,
 158–159
- triacylglycerol lipase, 150
- trimethoprim, 275
- triose phosphate isomerase, 34
- triparanol, 201
- tumor lysis syndrome, 304–305
- tyrosine degradation, 222–223
- tyrosine transaminase, 223
- tyrosinemia, 227
- ubiquinone, *see* coenzyme Q, 78
- ubiquitin, 28
- UDP-galactose, 50
- UDP-glucose
 in galactose degradation, 50
- UDP-galactose epimerase, 50, 53
- UDP-glucose

Index

- glycogen synthesis, 116
- UDP-glucuronic acid
 - biosynthesis, 117
- ulcers, gastric and duodenal, 10
- uncoupling proteins, 73, 244
- URAT1 transporter, 299
- urate oxidase, *see* uricase
- urea cycle
 - distribution of enzyme activity(, 217
 - distribution of enzyme activity), 218
 - enzyme defects, 219
 - alternate pathway therapy, 350
 - integration with other pathways, 213-216
 - reactions, 212-213
 - regulation, 218-219
- uric acid
 - degradation in non-primates, 299-300
 - formation, 299
 - renal elimination, 299
- uricase, 299
 - therapeutic use, 305
- uricosuric drugs, 299, 303
- uridine triphosphate (UTP)
 - glycogen synthesis, 117
- uroporphyrinogen decarboxylase, 326
- uroporphyrinogen III cosynthase, 325
- uroporphyrinogen III decarboxylase
 - deficiency, 328
- very low density lipoprotein, 183
- vitamin B₁₂
 - propionate utilization, 157
- vitamin B₁₂, *see* cobalamin
- vitamin B₆ deficiency, 327
- vitamin D, 178
- vitamin E, 197
- VLDL, *see* very low density lipoprotein
- von Gierke disease, 126-127
- xanthine, 299
- xanthine dehydrogenase/oxidase, 297, 298, 303, 313
- xanthosine monophosphate (XMP), 294
- xenobiotic response elements, 342
- xylose, 36
- xylulose-5-phosphate, 133