



## Experiment No.4

### Diode Applications 1

### Clipping and Clamping Circuits

#### Object

The purpose of this experiment is to demonstrate the operation of diode clipping and clamping circuits.

#### Required Parts and Equipment's

1. Function Generator
2. Electronic Test Board (M50)
3. Dual-Channel Oscilloscope
4. DC Power Supply
5. Silicon Diode 1N4001
6. Resistors,  $R_1 = 1K\Omega$ ,  $R_2 = 2K\Omega$
7. Leads and Adaptors

#### Theory

In addition to the use of diodes as rectifiers, there are a number of other interesting applications. For example, diodes are frequently used in applications such as wave-shaping, detectors, voltage multipliers, switching circuits, protection circuits, and mixers. In this experiment, we will investigate two widely used applications of diode circuits, namely diode clipping circuits and diode clamping circuits.

##### ▪ **Half-Wave Rectifier**

Diode clipping circuits are wave-shaping circuits that are used to prevent signal voltages from going above or below certain levels. The clipping level may be either equal to the diode's barrier potential or made variable with a DC voltage source (or bias voltage). Because of this limiting capability, the clipper is also called a limiter.

There are, in general, two types of clipping circuits: parallel clippers and series clippers. In parallel clippers, the diode is connected in a branch parallel to the load, while in series clippers, the diode is connected in series with the load.

Fig.1 presents a simple diode clipping circuit. This circuit is known as the unbiased parallel diode clipper, and is used to clip or limit the positive part of the input voltage. As the input voltage goes positive, the diode becomes forward-biased. The anode of the diode in this case is at a potential of 0.7V with respect to the cathode. So, the output voltage will be limited to 0.7V when the input voltage exceeds this value. When the input voltage goes back below 0.7V, the diode is reverse-biased and appears as an open circuit. The output voltage will look like the negative part of the input voltage.

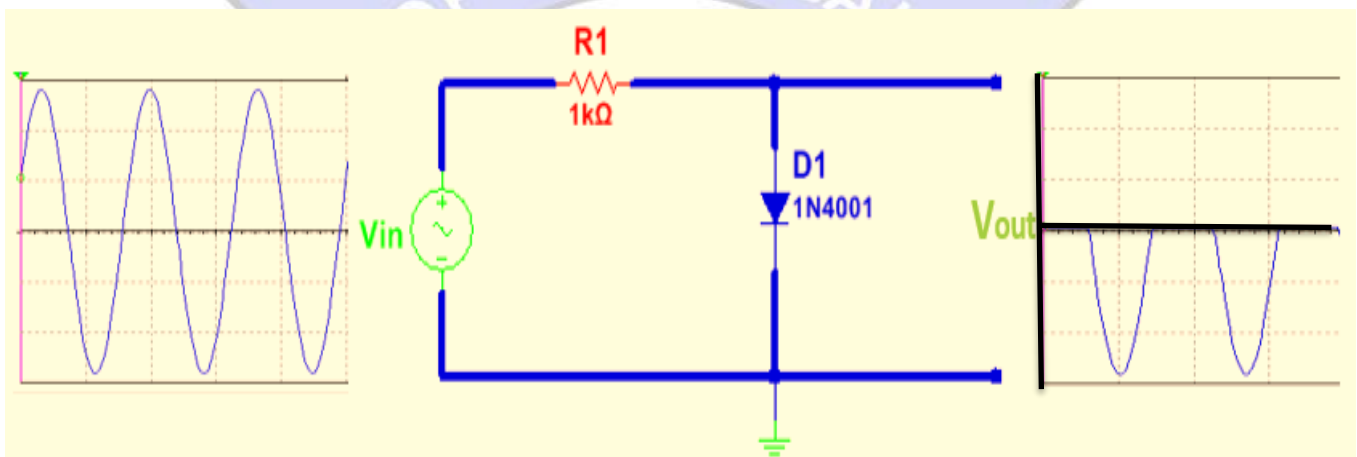

Figure 1: Simple Unbiased Parallel Diode Clipping Circuit

The level to which an AC voltage is limited can be adjusted by adding a bias voltage  $V_B$  in series with the diode as shown in Fig.2.

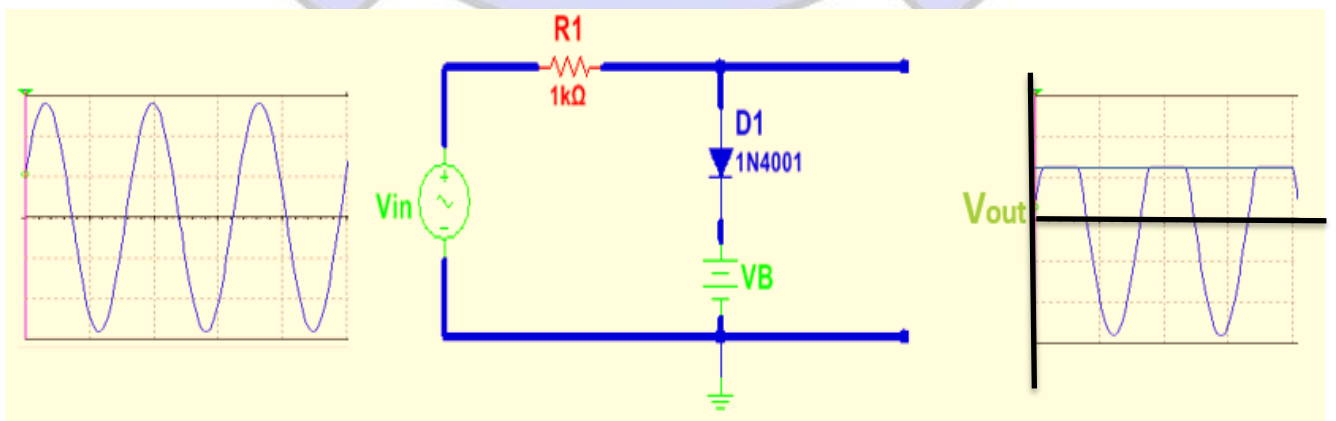

Figure 2: Biased Parallel Diode Clipping Circuit

In this circuit, the input voltage must equal  $V_B + 0.7V$  before the diode will become forward biased and conduct. Once the diode begins to conduct, the output voltage is limited to  $V_B + 0.7V$  so that all input voltage above this level is clipped off.

In Fig.3, a simple series diode clipping circuit is presented. Its action is actually similar to that of the half-wave rectifier.

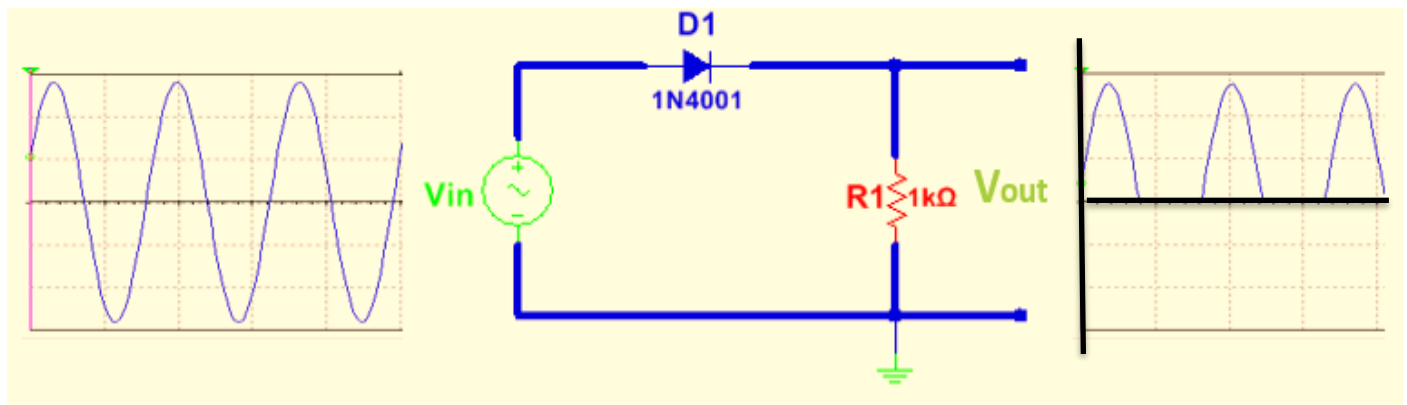

Figure 3: Simple Unbiased Series Diode Clipping Circuit

When the input signal goes positive and exceeds  $0.7V$ , the diode becomes forward-biased and the output voltage is  $V_{in} - 0.7V$ . When the input voltage becomes less than  $0.7V$ , the diode becomes reverse-biased and no current flows in the circuit resulting in zero output voltage. Fig.4 shows a biased series clipping circuit.

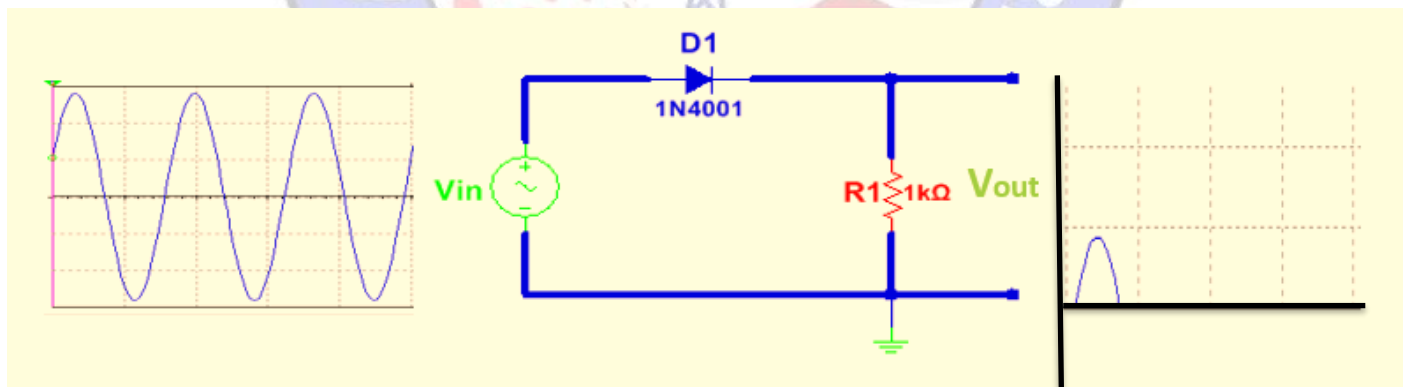

Figure 4: Biased Series Diode Clipping Circuit

When the input voltage is less than  $V_B + 0.7V$ , the diode does not conduct and no current flows through the load, and hence the output voltage will be  $0V$ . If the input signal becomes larger than  $V_B + 0.7V$ , the diode will conduct and the output voltage becomes  $V_{in} - (V_B + 0.7)$ . The output voltage waveform will be as shown in Fig.4.

## ▪ Clamping Circuits

Diode clamping circuits are used to shift the DC level of a waveform. If a signal has passed through a capacitor, the DC component is blocked. A clamping circuit can restore the DC level. For this reason, these circuits are sometimes called DC restorers. There are two kinds of clamping circuits, positive clampers and negative clampers.

Fig.5 shows a positive diode clamper that inserts a positive DC level in the output waveform.

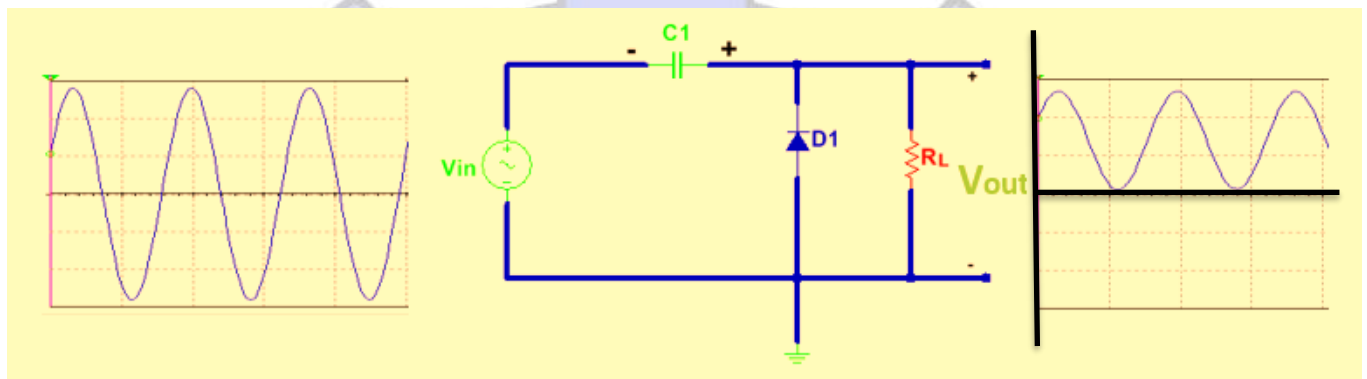

Figure 5: Unbiased Positive Clamping Circuit

During the negative half cycle, the diode conducts and the capacitor charges to  $V_p$  volts (assuming ideal diode). In the positive half cycle, the capacitor which was charged initially, discharges through the resistor by a time constant  $RLC$ . This happens only if  $RLC$  time constant is much less than half the time period of the waveform. Hence if  $RLC$  is larger than half the time period, it will not discharge through  $RL$ . Now  $C$  acts as a DC battery of  $V_p$  volt.

Hence during the positive half cycle, the diode is reverse biased by  $(V_{in} + V_p)$  volts, which appears across it. The magnitude of  $RL$  and  $C$  must be chosen such that the time constant  $\tau = RLC$  is large enough to ensure the voltage across the capacitor does not discharge significantly during the interval of the diode when it is non-conducting ( $\tau \gg T$ ). So, for an acceptable approximation we have:

$$R_L \cdot C \cong 10T$$

Where  $T$  is the time period of the input signal.

Biased clamping circuits produce an output waveform which is clamped by a variable level defined by a bias voltage source connected in series with the diode. If a battery of value  $V_B$  is added to forward bias the diode of Fig.5 then the clamping level of the output waveform is raised from  $V_p$  to  $V_p + V_B$  volts. Consider Fig.6, where a biased positive clamper circuit is presented. The capacitor gets charged to  $V_p + V_B$  volts assuming an ideal diode. In the positive half cycle the same C acts as a battery of  $V_p + V_B$  volts, and hence the output is  $(V_{in} + V_p + V_B)$  volts.

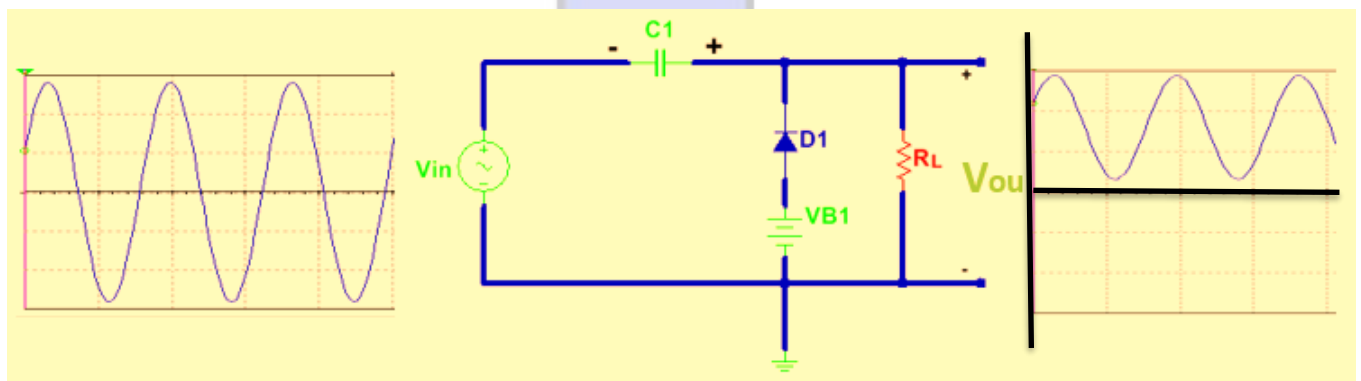

Figure 6: Biased Positive Clamping Circuit

### Procedure

1. Connect the clipping circuit shown in Fig.7, and apply a 20Vpp sinusoidal input waveform with frequency of 1 kHz at the input. Display and sketch both input and output signals.

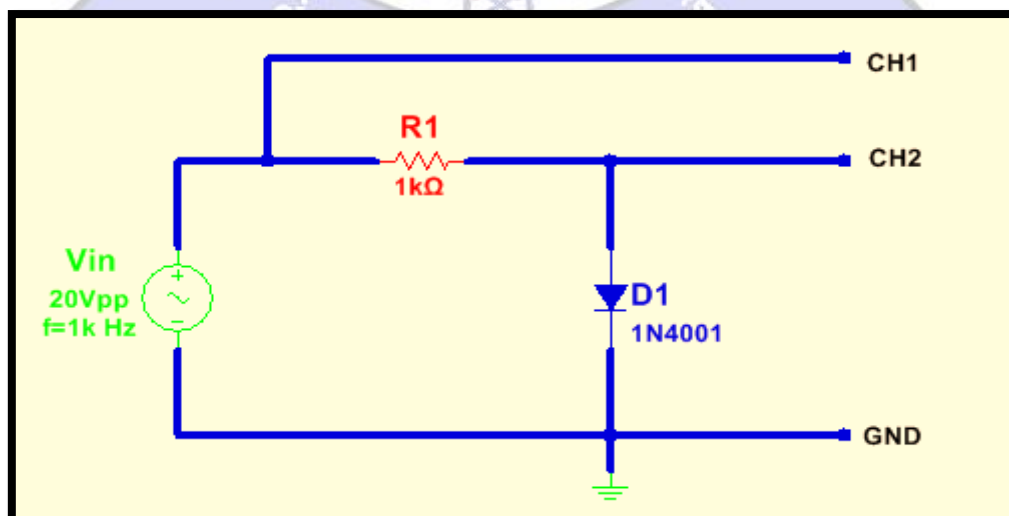

Figure 7: Practical Unbiased Parallel Clipping Circuit

2. Connect the biased parallel clipping circuit shown in Fig.8, and apply a 20Vpp sinusoidal input waveform with frequency of 1 kHz at the input. Display and sketch the input and the output waveforms.

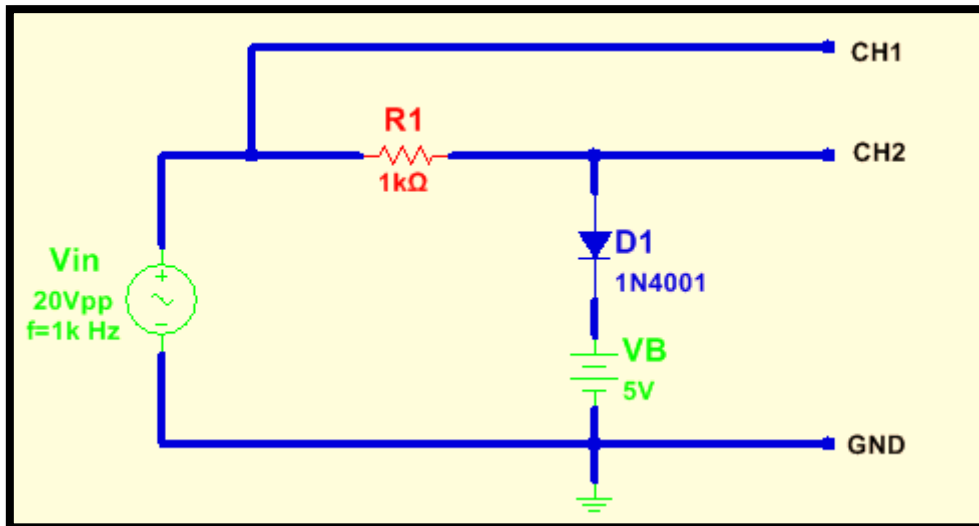

Figure 8: Practical Biased Parallel Clipping Circuit

3. Connect the series clipping circuit shown in Fig.9, and apply a 20Vpp sinusoidal input waveform with frequency of 1 kHz at the input. Display and sketch the input and the output waveforms.

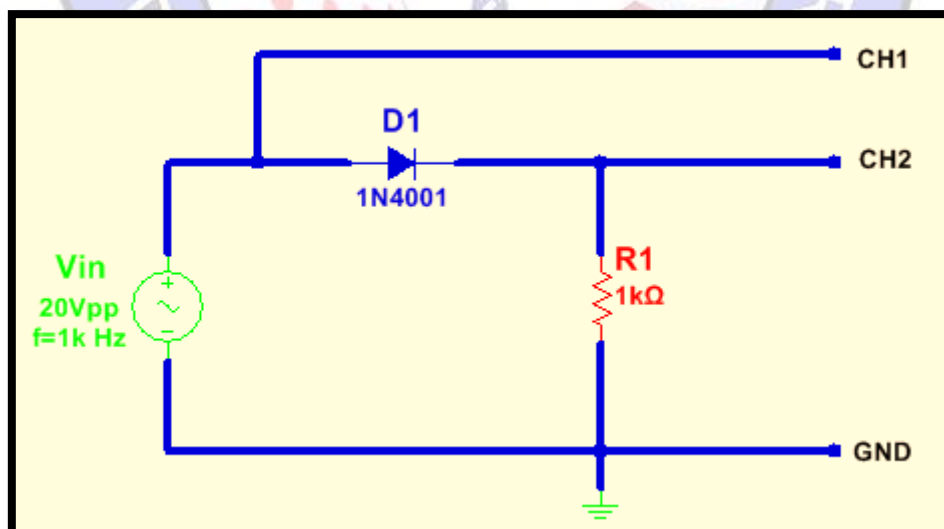

Figure 9: Practical Unbiased Series Clipping Circuit

4. Connect the biased series clipping circuit shown in Fig.10, and apply a 20Vpp sinusoidal input waveform with frequency of 1 kHz at the input. Display and sketch the input and the output waveforms.

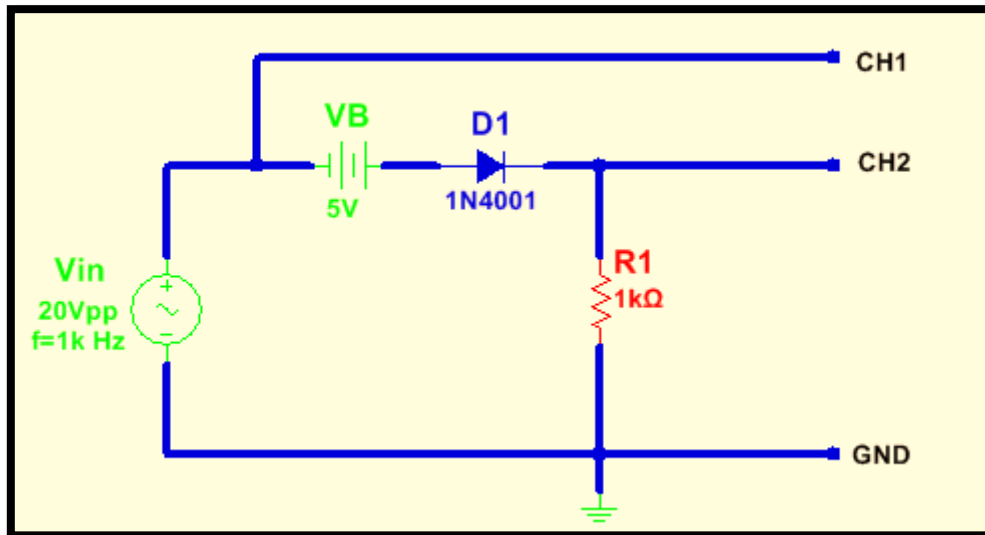

Figure 10: Practical Biased Series Clipping Circuit

5. Connect the clamping circuit shown in Fig.11, and apply a 10Vpp sinusoidal input waveform with frequency of 1 kHz at the input. Display and sketch the input and the output waveforms.

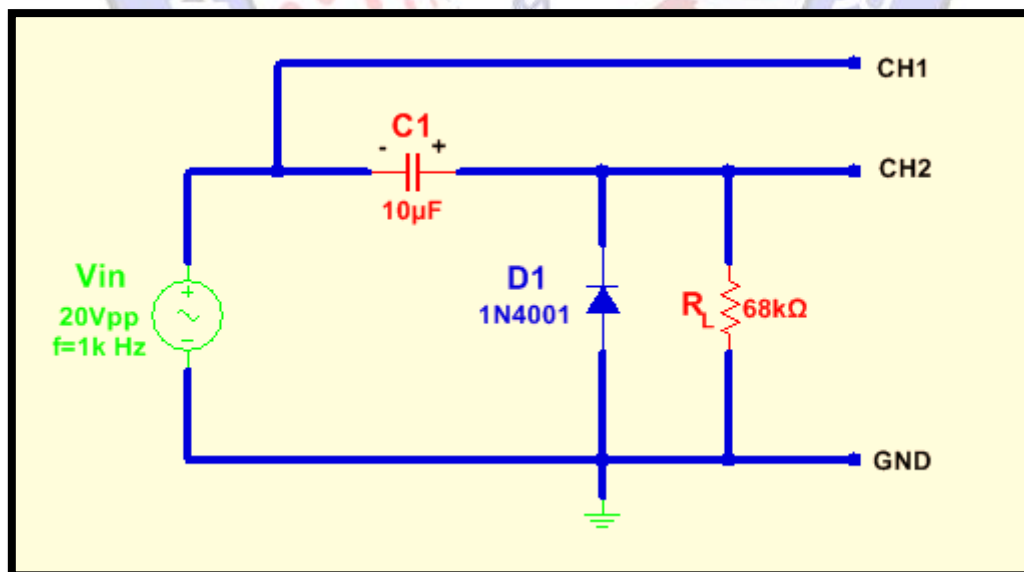

Figure 11: Practical Unbiased Positive Clamping Circuit

- Repeat step 5 after applying a square wave of 10Vpp amplitude and 1 kHz frequency.
- Connect the biased positive clamping circuit shown in Fig.12, and apply a 10Vpp sinusoidal input waveform with frequency of 1 kHz at the input. Display and sketch the input and the output waveforms.

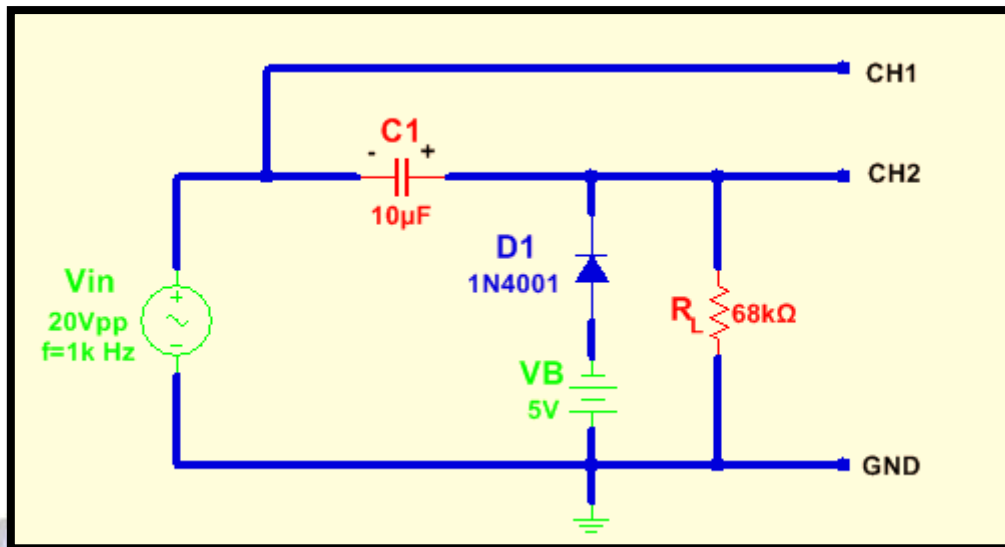

Figure 12: Practical Biased Positive Clamping Circuit

- Repeat step 7 after applying a square wave of 10Vpp amplitude and 1 kHz frequency.

### Calculations and Discussion

- What is the effect of the diode voltage drop on the output of the clipping circuit in Fig.4? Compare the waveforms with those obtained when assuming ideal diodes.
- If the diode in the circuit of Fig.2 was reversed, then sketch the output waveform in this case and explain briefly the operation of the circuit.
- Design a clipping circuit that will limit the output voltage to 5V when applying an input sinusoidal waveform with a peak value of 10V. Assume available diodes with voltage drop of 0.5V. Sketch the output waveform of the circuit.
- Sketch the output waveform for the clipping circuit of Fig.1, if a load resistance  $R_L$  of value 1 kΩ is connected at the output terminals in parallel with the diode.
- Discuss how diode limiters and diode clampers differ in terms of their function.





6. Design a clamper circuit that shifts the DC level of an input sinusoidal waveform by +6V if the peak value of the input signal is 3V, and its frequency is 500 Hz. Assume diode voltage drop is 0.6V.
7. What is the effect of reducing the load resistor on the output of the clamper circuit shown in Fig.5 if the input signal is a square wave?
8. What is the difference between a positive clamper and a negative clamper? Explain with the aid of circuit diagrams and output waveforms.

