



4- Starting Methods for Induction Motors

A 3-phase induction motor is theoretically self starting. The stator of an induction motor consists of 3-phase windings, which when connected to a 3-phase supply creates a rotating magnetic field. This will link and cut the rotor conductors which in turn will induce a current in the rotor conductors and create a rotor magnetic field. The magnetic field created by the rotor will interact with the rotating magnetic field in the stator and produce rotation.

Therefore, 3-phase induction motors employ a starting method not to provide a starting torque at the rotor, but because of the following reasons;

- 1) Reduce heavy starting currents and prevent motor from overheating.
- 2) Provide overload and no-voltage protection.

There are many methods in use to start 3-phase induction motors. Some of the common methods are;

- 1- Direct On-Line Starter (DOL)
- 2- Star-Delta Starter
- 3- Auto Transformer Starter
- 4- Rotor Impedance Starter
- 5- Power Electronics Starter

4-1 Direct On-Line Starter (DOL)

The Direct On-Line (DOL) starter is the simplest and the most inexpensive of all starting methods and is usually used for squirrel cage induction motors. It directly connects the Contacts of the motor to the full supply voltage. The starting current is very large, normally 6 to 8 times the rated current. The starting torque is likely to be 0.75 to 2 times the full load Torque. In order to avoid excessive voltage drops in the supply line due to high starting currents, the DOL starter is used only for motors with a rating of less than 5KW

There are safety mechanisms inside the DOL starter which provides protection to the motor as well as the operator of the motor. The power and control circuits of induction motor with DOL starter are shown in figure(1).

* K1M Main contactor

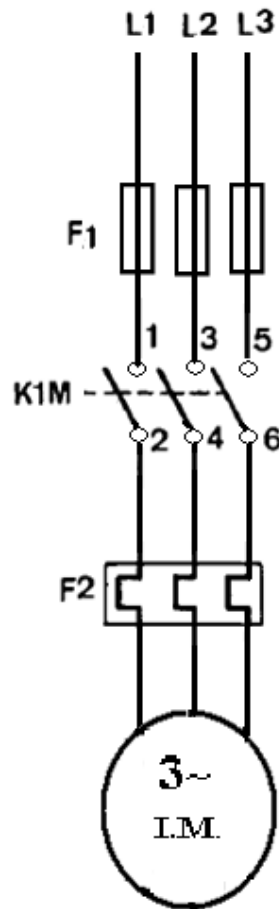

Fig.(1): power and control circuits of I.M. with DOL starter

4-2 Star-Delta Starter

The star delta starting is a very common type of starter and extensively used, compared to the other types of the starters.

This method used reduced supply voltage in starting. Figure(2) shows the connection of a 3phase induction motor with a star – delta starter.

The method achieved low starting current by first connecting the stator winding in star configuration, and then after the motor reaches a certain speed, throw switch changes the winding arrangements from star to delta configuration. By connecting the stator windings, first in star and then in delta, the line current drawn by the motor at starting is reduced to one-third as compared to starting current with the windings connected in delta. At the time of starting when the stator windings are start connected, each stator phase gets voltage $\frac{V_l}{\sqrt{3}}$, where V_l is the line voltage. Since the torque developed by an induction motor is proportional to the square of the applied voltage, star- delta starting reduced the starting torque to one – third that obtainable by direct delta starting.

- K2M Main Contactor
- K3M Delta Contactor
- K1M Star Contactor

□ F1 Thermal Overload Relay

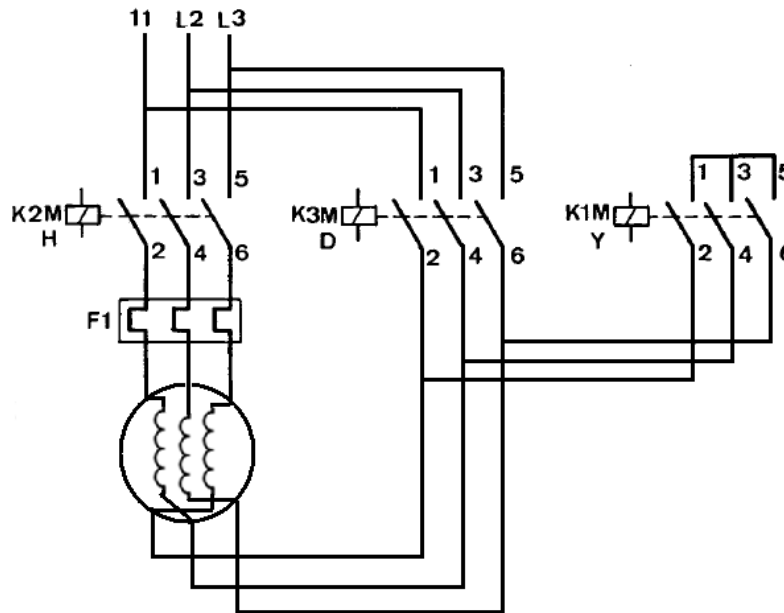

Fig.(2) Induction Motor with Star Delta Starter

4-3 Auto Transformer Starter

The operation principle of auto transformer method is similar to the star delta starter method. The starting current is limited by (using a three phase auto transformer) reduce the initial stator applied voltage. The auto transformer starter is more expensive, more complicated in operation and bulkier in construction when compared with the star – delta starter method. But an auto transformer starter is suitable for both star and delta connected motors, and the starting current and torque can be adjusted to a desired value by taking the correct tapping from the auto transformer. When the star delta method is considered, voltage can be adjusted only by factor of $\frac{1}{\sqrt{3}}$ Figure (3) shows the connection of a 3phase induction motor with auto transformer starter.

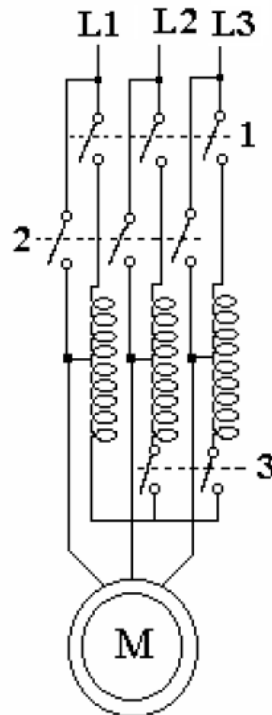

Fig.(3) shows I.M with auto transformer starter.

4-4 Rotor Impedance Starter

This method allows external resistance to be connected to the rotor through slip rings and brushes. Initially, the rotor resistance is set to maximum and is then gradually decreased as the motor speed increases, until it becomes zero.

The rotor impedance starting mechanism is usually very bulky and expensive when compared with other methods. It also has very high maintenance costs. Also, a considerable amount of heat is generated through the resistors when current runs through them. The starting frequency is also limited in this method. However, the rotor impedance method allows the motor to be started while on load. Figure (4) shows the connection of a 3phase induction motor with rotor resistance starter.

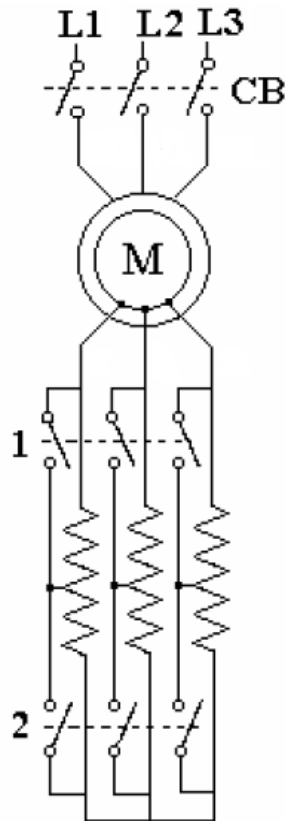

Fig. (4) Shows the I.M. with rotor resistance starter.

Example (9):

It is desired to install a 3-phase cage induction motor restricting the maximum line current drawn from a 400 V 3-phase supply to 120 A. if the starting current is 6 times full load current, what is the maximum permissible full load kVA of the motor when

- i. It is directly connected to the mains
- ii. It is connected through an auto-transformer with a tapping of 60%
- iii. It is designed for used with star-delta starter.

Solution:

i. Direct-on-line starting

Maximum line current, $I_L = 120A$

Starting current $I_{st} = 6 \times \text{full load current} = 6I_{fl}$

Since the maximum line current drawn from the supply is 120A

$$6I_{ft} = 120, \quad I_f = \frac{120}{6} = 20A$$

Maximum permissible rating of the motor

$$= \sqrt{3}V_L I_{ft} = \sqrt{3} \times 20 \times 400 = 13856 \text{ VA} = 13.856 \text{ k VA}$$



ii. **Auto-transformer starting**

$$I_{st} = x^2 I_{sc} = x^2 (6I_{ft})$$

$$120 = (0.6)^2 (6I_{ft})$$

$$I_{ft} = \frac{120}{6 \times (0.6)^2} = 55.55A$$

Maximum permissible rating of the motor

$$= \sqrt{3} V_L I_{ft} = \sqrt{3} \times 400 \times 55.55 = 38.49 \text{ kVA}$$

iii. **Star-delta starting**

$$I_{st} = \frac{1}{3} (6I_{ft})$$

$$120 = 2I_{ft}, \quad I_{ft} = 60A$$

Maximum permissible kVA rating of the motor

$$= \sqrt{3} V_L I_{ft} = \sqrt{3} \times 400 \times 60 = 41.56 \text{ kVA}$$

