

Lecture 7 - Protein Synthesis: Transcription and Translation

DNA contains codes

Three bases in DNA code for one amino acid. The DNA code is copied to produce mRNA. The order of amino acids in the polypeptide is determined by the sequence of 3-letter codes in mRNA.

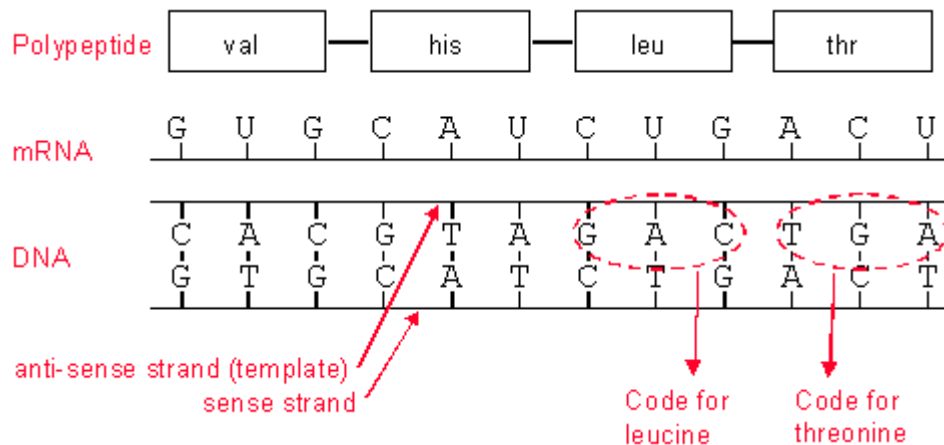

DNA vs RNA

	<u>DNA</u>	<u>RNA</u>
Sugar:	deoxyribose	ribose
Bonds with Adenine:	thymine	uracil
# of Strands:	two	one

Kinds of RNA

Messenger RNA (mRNA)

Messenger RNA contains genetic information. It is a copy of a portion of the DNA.

It carries genetic information from the gene (DNA) out of the nucleus, into the cytoplasm of the cell where it is translated to produce protein.

Ribosomal RNA (rRNA)

This type of RNA is a structural component of the ribosomes. It does not contain a genetic message.

Transfer RNA (tRNA)

Transfer RNA functions to transport amino acids to the ribosomes during protein synthesis.

Transcription

Transcription is the synthesis of mRNA from a DNA template.

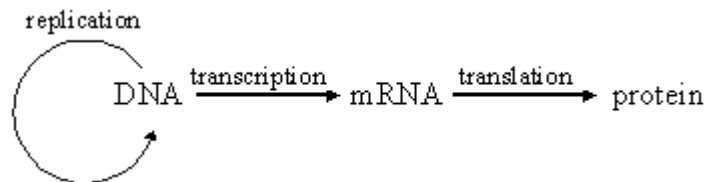

It is like DNA replication in that a DNA strand is used to synthesize a strand of mRNA.

Only one strand of DNA is copied.

A single gene may be transcribed thousands of times.

After transcription, the DNA strands rejoin.

Steps involved in transcription

DNA unwinds.

RNA polymerase recognizes a specific base sequence in the DNA called a **promoter** and binds to it. The promoter identifies the start of a gene, which strand is to be copied, and the direction that it is to be copied.

Complementary bases are assembled (U instead of T).

A **termination code** in the DNA indicates where transcription will stop.

The mRNA produced is called a **mRNA transcript**.

Processing the mRNA Transcript

In eukaryotic cells, the newly-formed mRNA transcript (also called heterogenous nuclear RNA or hnRNA) must be further modified before it can be used.

A cap is added to the 5' end and a poly-A tail (150 to 200 Adenines) is added to the 3' end of the molecule.

The newly-formed mRNA has regions that do not contain a genetic message. These regions are called *introns* and must be removed. Their function is unknown.

The remaining portions of mRNA are called *exons*. They are spliced together to form a *mature mRNA transcript*.

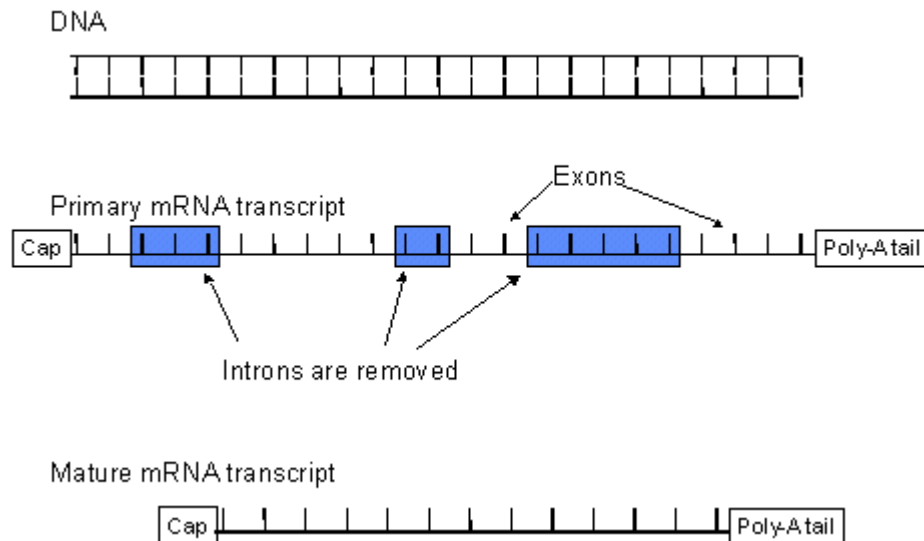

The Nucleus

DNA is located in an organelle called the [*nucleus*](#).

Transcription and mRNA processing occur in the nucleus.

The nucleus is surrounded by a double membrane. After the mature mRNA transcript is produced, it moves out of the nucleus and into the [*cytoplasm*](#) through *pores* in the *nuclear membrane*.

Translation

Translation is the process where ribosomes synthesize proteins using the mature mRNA transcript produced during [*transcription*](#).

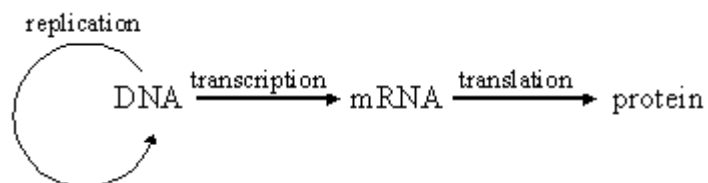

Overview

The diagram below shows a ribosome attach to mRNA, and then move along the mRNA adding amino acids to the growing polypeptide chain.

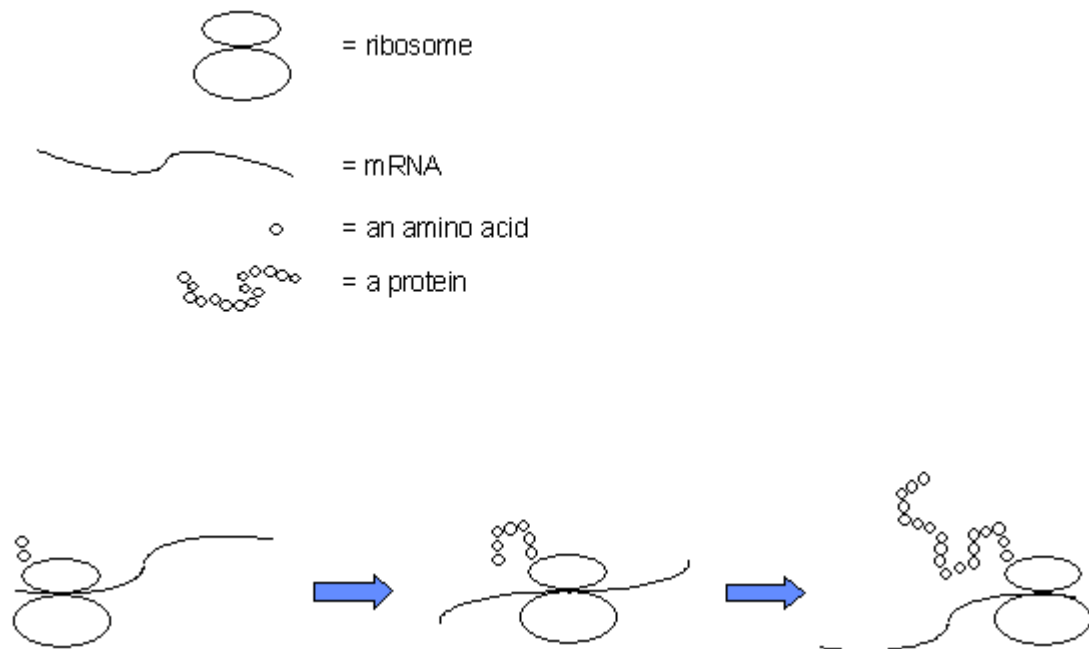

Translation - Details

A mature mRNA transcript, a ribosome, several tRNA molecules and amino acids are shown. There is a specific tRNA for each of the 20 different amino acids.

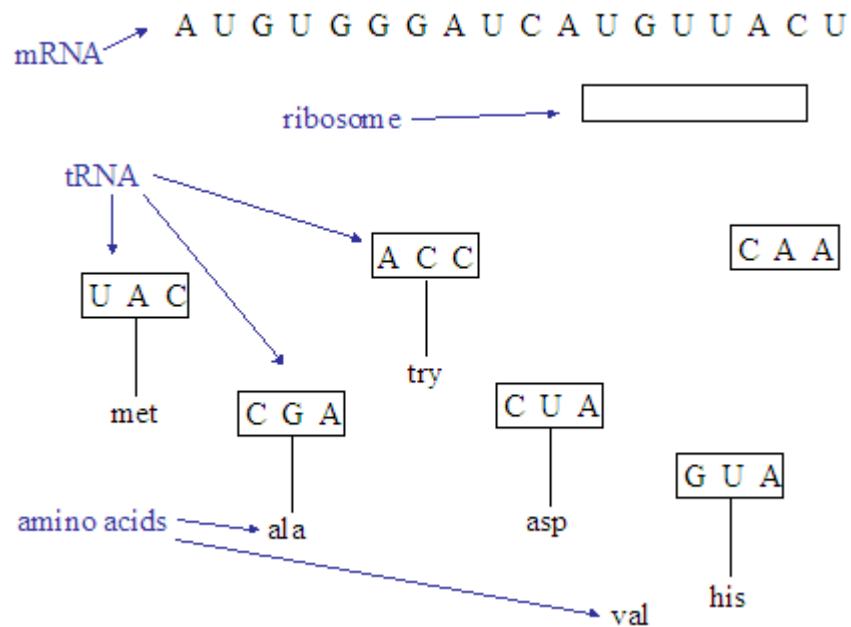

Below: A ribosome attaches to the mRNA transcript.

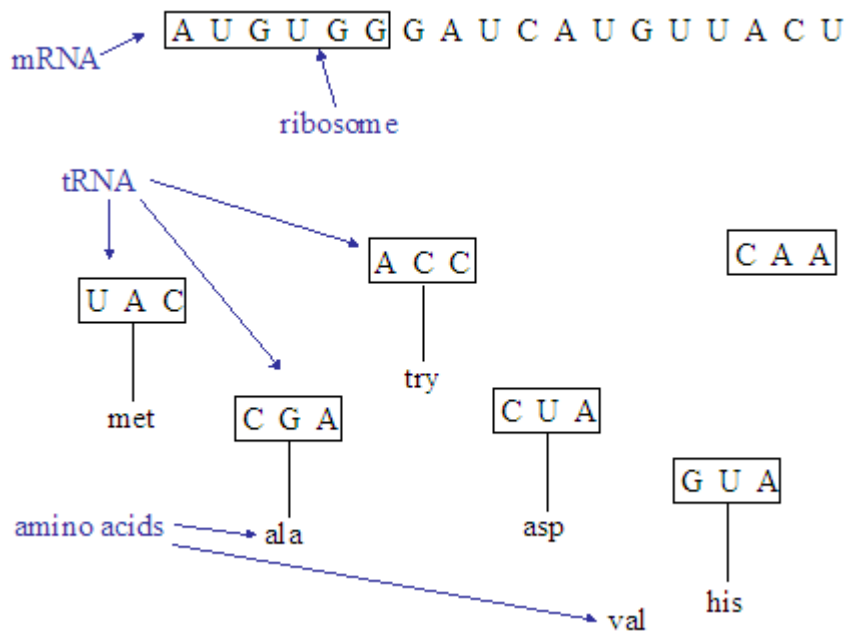

A tRNA molecule transports an amino acid to the ribosome. Notice that the 3-letter **anticodon** on the tRNA molecule matches the 3-letter code (called a **codon**) in the mRNA. The tRNA with the anticodon "UAC" bonds with methionine. It always transports methionine. Transfer RNA molecules with different anticodons transport other amino acids.

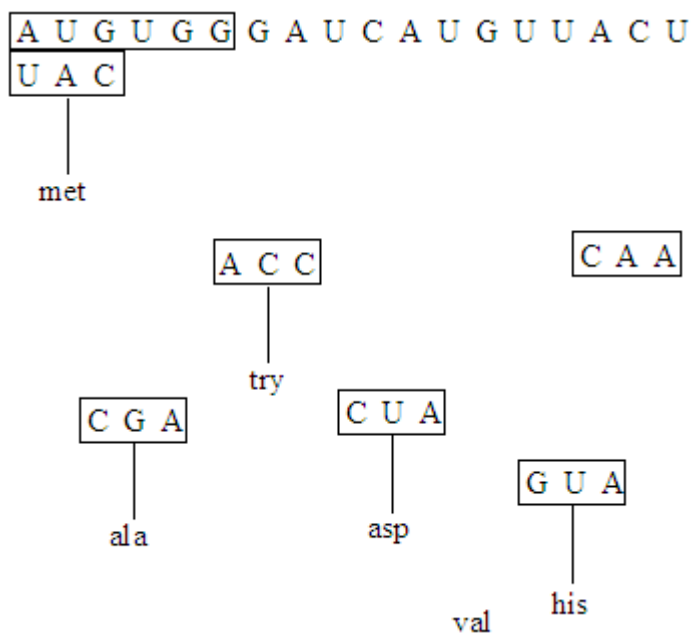

A second tRNA molecule bonds to the mRNA at the ribosome. Again, the codes must match.

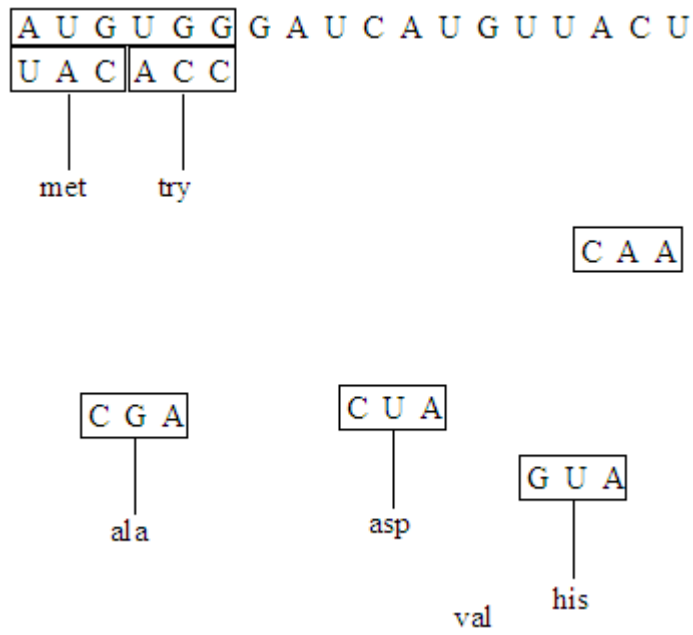

A bond is formed between the two amino acids.

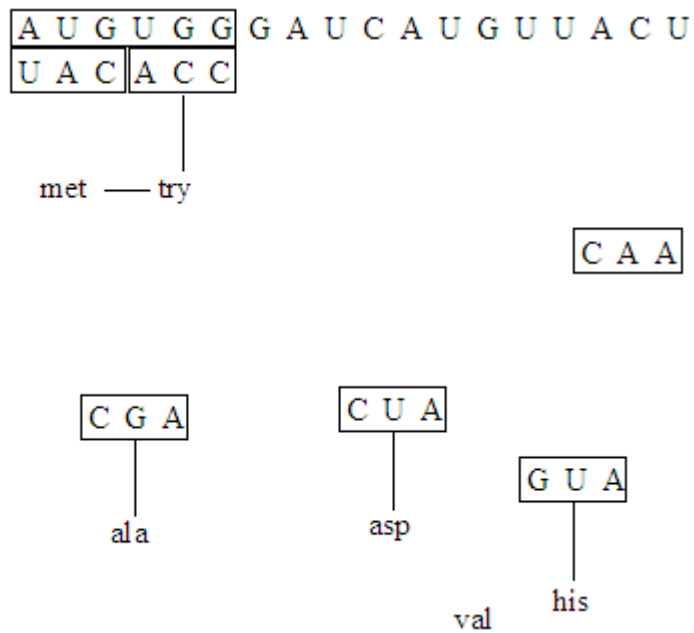

The tRNA bonded to methionine drops off and can be reused later.

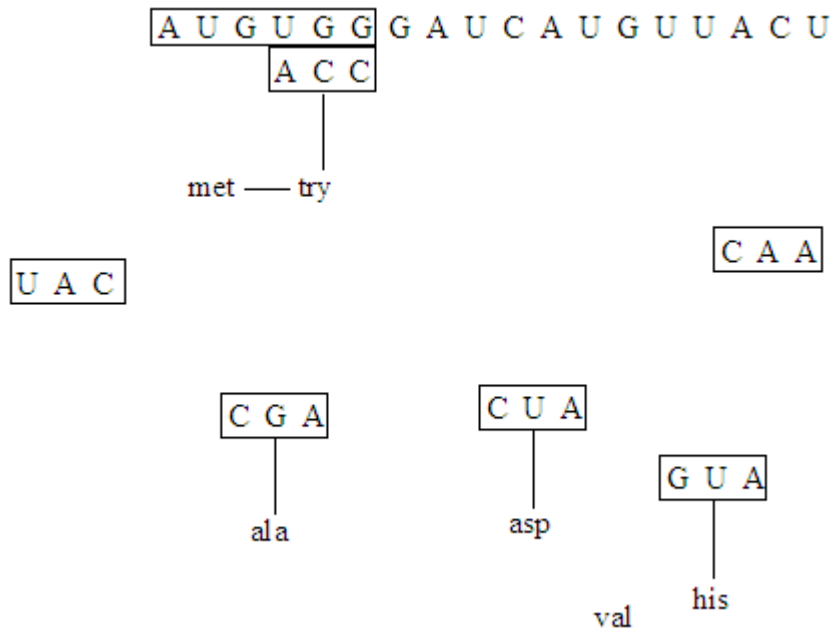

The ribosome moves along the mRNA to expose another codon (GAU) for a tRNA molecule.

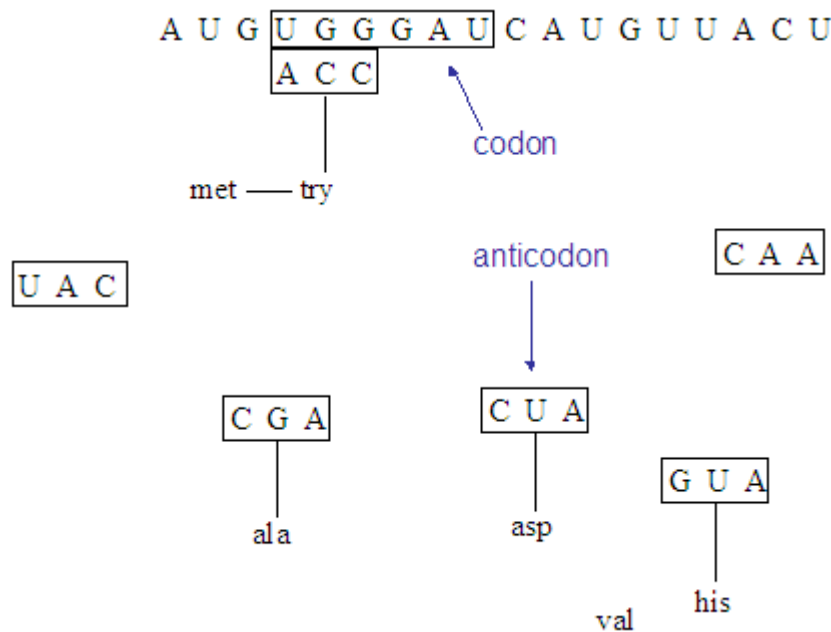

The only tRNA molecule that can bond to the GAU site is a molecule with a CUA anticodon. Transfer RNA molecules with CUA anticodons are specific for asparagine.

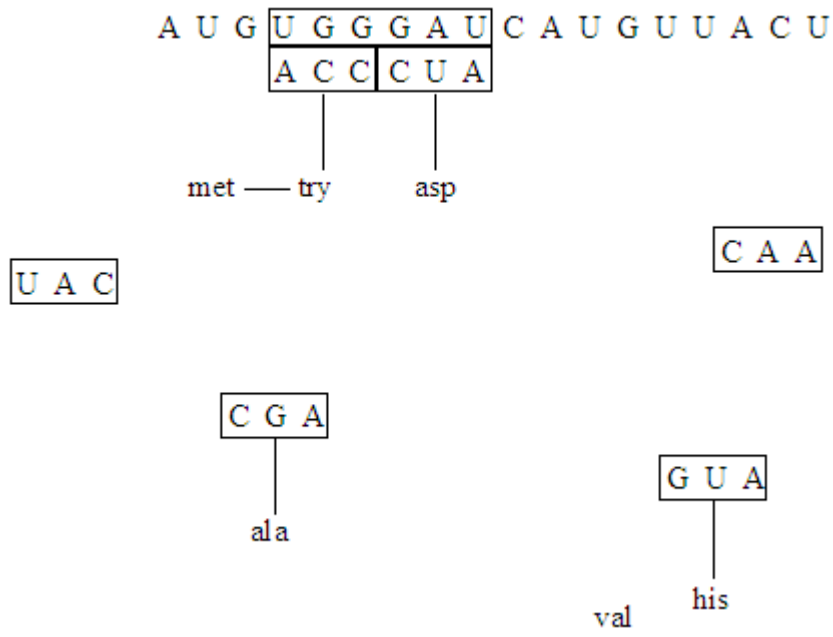

Asparagine is now added to the growing amino acid chain.

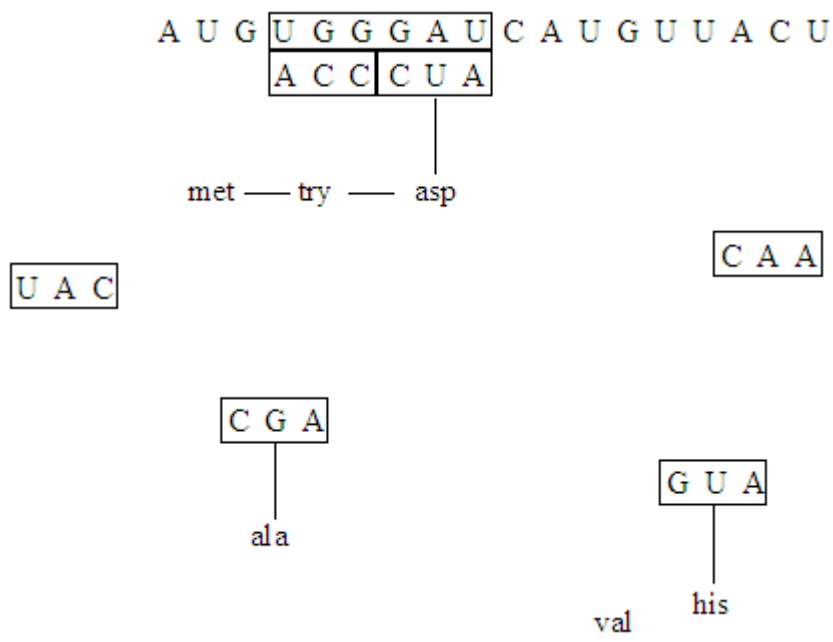

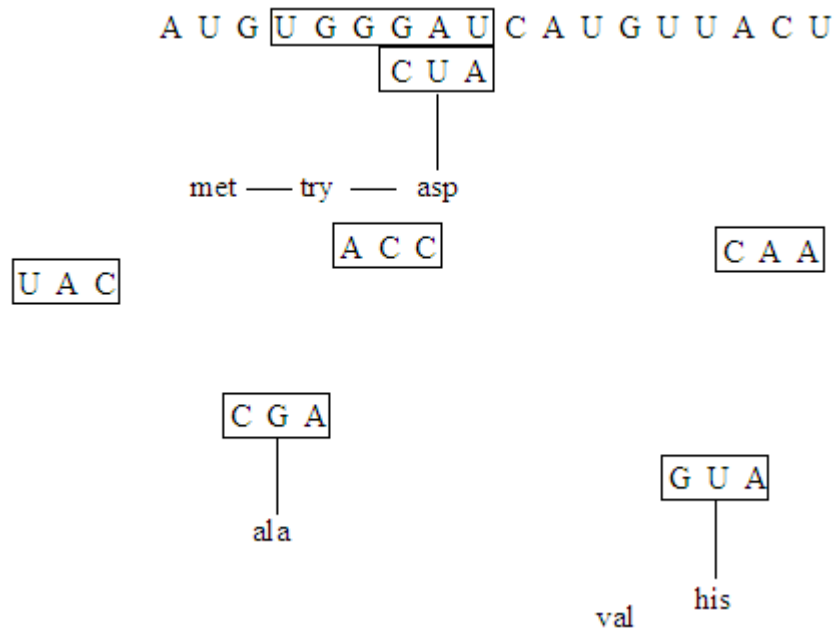

Summary Animation of Translation on the Internet

[Click here](#) to view an animation of translation.

[Click here](#) to go to a web page that shows an animation of translation. Go to the bottom of the page and then click translation.

Initiation and Termination Codes

An *initiation code* signals the start of a genetic message. As the ribosome moves along a mRNA transcript, it will not begin synthesizing protein until it reaches an initiation code.

Termination codes signal the end of the genetic message. Synthesis stops when the ribosome reaches a terminator codon.

Genetic Code

The table below can be used to determine what amino acid corresponds to any 3-letter codon.

First Base	Second Base				Third Base
	U	C	A	G	
U	UUU phenylalanine	UCU serine	UAU tyrosine	UGU cysteine	U
	UUC phenylalanine	UCC serine	UAC tyrosine	UGC cysteine	C

	UUA leucine	UCA serine	UAA stop	UGA stop	A
	UUG leucine	UCG serine	UAG stop	UGG tryptophan	G
C	CUU leucine	CCU proline	CAU histidine	CGU arginine	U
	CUC leucine	CCC proline	CAC histidine	CGC arginine	C
	CUA leucine	CCA proline	CAA glutamine	CGA arginine	A
	CUG leucine	CCG proline	CAG glutamine	CGG arginine	G
A	AUU isoleucine	ACU threonine	AAU asparagine	AGU serine	U
	AUC isoleucine	ACC threonine	AAC asparagine	AGC serine	C
	AUA isoleucine	ACA threonine	AAA lysine	AGA arginine	A
	AUG (start) methionine	ACG threonine	AAG lysine	AGG arginine	G
G	GUU valine	GCU alanine	GAU aspartate	GGU glycine	U
	GUC valine	GCC alanine	GAC aspartate	GGC glycine	C
	GUA valine	GCA alanine	GAA glutamate	GGA glycine	A
	GUG valine	GCG alanine	GAG glutamate	GGG glycine	G

Mutation

Mutations are changes in the DNA.

Frameshift

A frameshift mutation is usually severe, producing a completely nonfunctional protein.

The principle of a frameshift can be explained using the sentence below. If the letters are read three at a time and one is deleted, the second sentence becomes meaningless.

Original DNA: THE BIG RED ANT ATE ONE FAT BUG
Frameshift mutation: THB IGR EDA NTA TEO NEF ATB UG?

Point Mutation

Point mutations involve a single nucleotide, thus a single amino acid.

In the sentence below, eliminating one letter does not change in the remaining three-letter words and therefore may not cause a significant change in the meaning of the sentence.

Original DNA: THE BIG RED ANT ATE ONE FAT BUG
Point mutation: THA BIG RED ANT ATE ONE FAT BUG

Silent, Missense, and Nonsense Mutations

Three kinds of point mutations can occur. A mutation that results in an amino acid substitution is called a missense mutation.

A mutation that results in a stop codon so that incomplete proteins are produced, it is called a nonsense mutation.

A mutation that produces a functioning protein is called a silent mutation.