



Encoder Circuit

OBJECTIVE

Understanding the operating principles of encoder circuits.

Summary

An encoder is a combinational logic gate that accept one or multiple inputs and generates a specific output code. Only one input is triggered at a time. An encoder with n-bit inputs and n-bit outputs is shown in Fig. 2-61. When one of the inputs is triggered there will be a n-bit output code at the outputs.

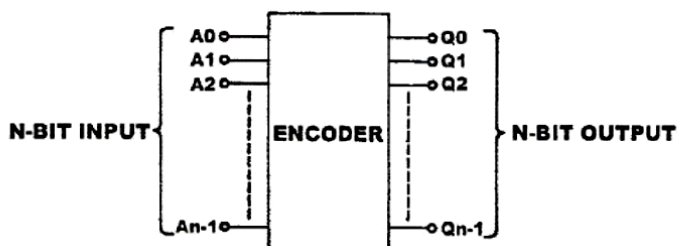

Fig. 2-61

Octal to Binary Encoder

An octal to binary encoder is shown in Fig. 2-62. There are 8 octal inputs A1~A7 (0~7); and three binary outputs Q0, Q1, Q2 (000~111). If input A0="0" the corresponding output Q2Q1Q0 is equal to "000".

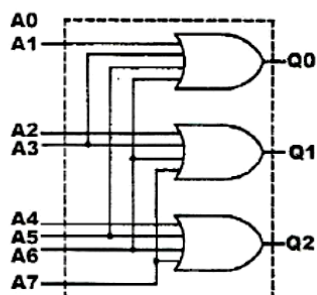

Fig. 2-62 Octal –Binary encoder



Actually, A0 is not connected to the gate input. If A1="1" then Q2Q1Q0=001. When A2="1" the output Q2Q1Q0=010. There can't be more than one "1" among the inputs. For example, if A2="1" and A3="1" simultaneously, Q2Q1Q0=011. If A3, A4 both are "1" at the same time, Q2Q1Q0=111. Both outputs are incorrect.

EQUIPMENTS REQUIRED

KL-31001 Digital Logic Lab; Modules KL-33005, KL-33006

PROCEDURES

(a) Constructing a 4-to-2 Encoder with Basic Gates

1. Insert connection clips according to Fig. 2-64.

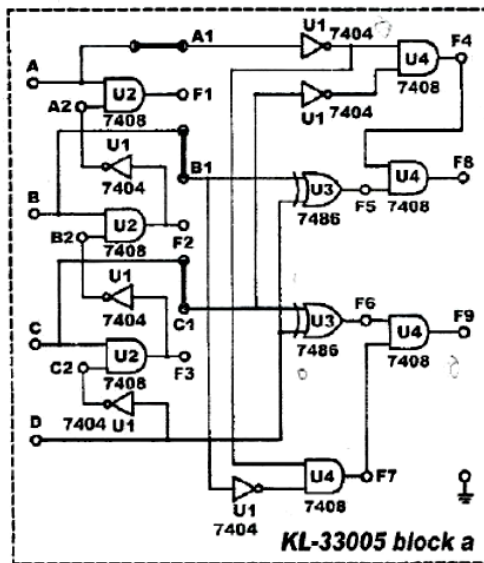

Fig. 2-64



2. Connect Vcc to +5V.
3. Connect inputs A~D to Data Switches SW0~SW3 respectively; outputs F8 and F9 to Logic Indicator L0 and L1.
4. Follow the input sequences for D, C, B, A in Table 2-28 and record the output states.

D	C	B	A	F8	F9
0	0	0	0		
0	0	0	1		
0	0	1	0		
0	0	1	1		
0	1	0	0		
0	1	0	1		
0	1	1	0		
0	1	1	1		
1	0	0	0		
1	0	0	1		
1	0	1	0		
1	0	1	1		
1	1	0	0		
1	1	0	1		
1	1	1	0		
1	1	1	1		

Table 2-28

5. Remove the connection clip between A and A1; insert it between A1 and F1 as shown in Fig. 2-65. All other connections remain the same. Follow the input sequences in Table 2-29 and record output states.

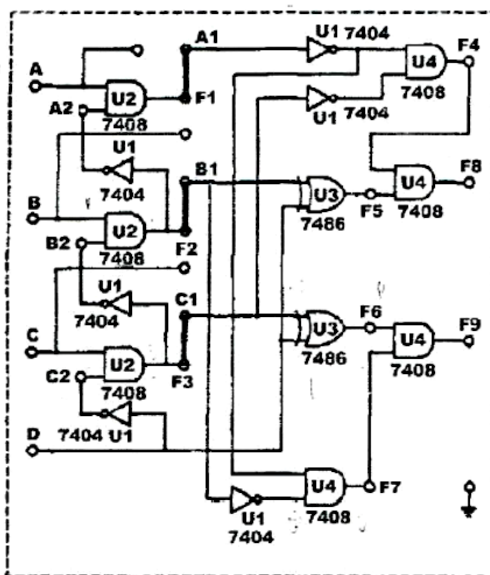

Fig. 2-65



D	C	B	A	F8	F9
0	0	0	0		
0	0	0	1		
0	0	1	0		
0	0	1	1		
0	1	0	0		
0	1	0	1		
0	1	1	0		
0	1	1	1		
1	0	0	0		
1	0	0	1		
1	0	1	0		
1	0	1	1		
1	1	0	0		
1	1	0	1		
1	1	1	0		
1	1	1	1		

Table 2-29

- Compare the outputs states in Table 2-28 and 2-29. What is the difference between them?

(b) Constructing a 9-to-4 Encoder with TTL IC

- The 74147 (U7) on block a of module KL-33006 is used in this section of the experiment. Connect Vcc to +5V.

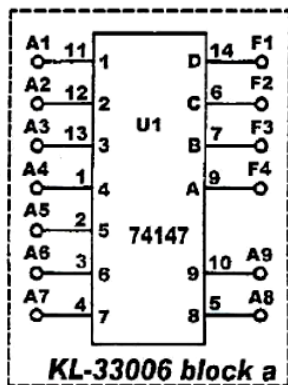

Fig. 2-66

- Connect inputs A0~A8 to DIP Switches 1.0~1.7, A9 to 2.0. Connect outputs F1~F4 to Logic indicators L1~L4. Follow the input sequences given in Table 2-30 and record output states.



A9	A8	A7	A6	A5	A4	A3	A2	A1	F4	F3	F2	F1
0	1	1	1	1	1	1	1	1				
0	0	1	1	1	1	1	1	1				
1	1	1	1	1	1	1	1	0				
1	1	1	1	1	1	1	0	0				
1	1	1	1	1	1	0	0	1				
1	1	1	1	1	0	0	0	0				
1	1	1	1	0	1	1	1	1				
1	1	1	1	0	0	0	0	1				
1	1	1	0	1	1	1	0	0				
1	1	0	1	1	0	1	1	0				
1	1	0	0	0	1	1	1	1				
1	0	0	0	0	0	1	1	1				

Table 2-30

DISCUSSION:

- 1- Design an encoder for coding 4 inputs and 2 outputs (Encoder 4× 2) ?
- 2- Design with drawing an octal-to-binary Encoder ?
- 3- Design the decimal to BCD Encoder ?